



Heating and Air Conditioning

**INSTALLATION MANUAL**

**LX SERIES**

**GEOHERMAL HEAT PUMPS**

**DUAL CAPACITY**

**MODELS:**

**YLF024 - 072**

**(2 THRU 6 NOMINAL TONS)**



Due to continuous product improvement, specifications are subject to change without notice.

Visit us on the web at [www.york-geothermal.com](http://www.york-geothermal.com)

Additional rating information can found at [www.ahridirectory.org](http://www.ahridirectory.org)

FOR DISTRIBUTION USE ONLY - NOT TO BE USED AT POINT OF RETAIL SALE



# Table of Contents

---

- Model Nomenclature ..... 4
- General Installation Information ..... 5-9
- Closed Loop Ground Source Systems ..... 11
- Open Loop Ground Water Systems ..... 12
- Hot Water Generator Connections ..... 13
- Electrical Connections ..... 15
- Electronic Thermostat Installation ..... 16
- Auxiliary Heat Ratings ..... 17
- Auxiliary Heat Electrical Data ..... 17
- Electrical Data ..... 17
- Blower Performance Data ..... 18
- Dimensional Data ..... 19
- Physical Data ..... 21
- The Aurora™ Control System ..... 22
- Reference Calculations ..... 26
- Legend ..... 27
- Wiring Schematics ..... 28
- Unit Startup ..... 32
- Operating Parameters ..... 33
- Pressure Drop ..... 38
- Compressor and Thermistor Resistance ..... 39
- Refrigerant Circuit Guideline ..... 40
- Heat of Extraction/Rejection ..... 41
- Correction Factor Tables ..... 42
- Antifreeze Corrections ..... 43
- Troubleshooting ..... 43
- Preventive Maintenance ..... 46
- Replacement Procedures ..... 46
- Service Parts List ..... 47
- Revision Guide ..... 49

# Model Nomenclature

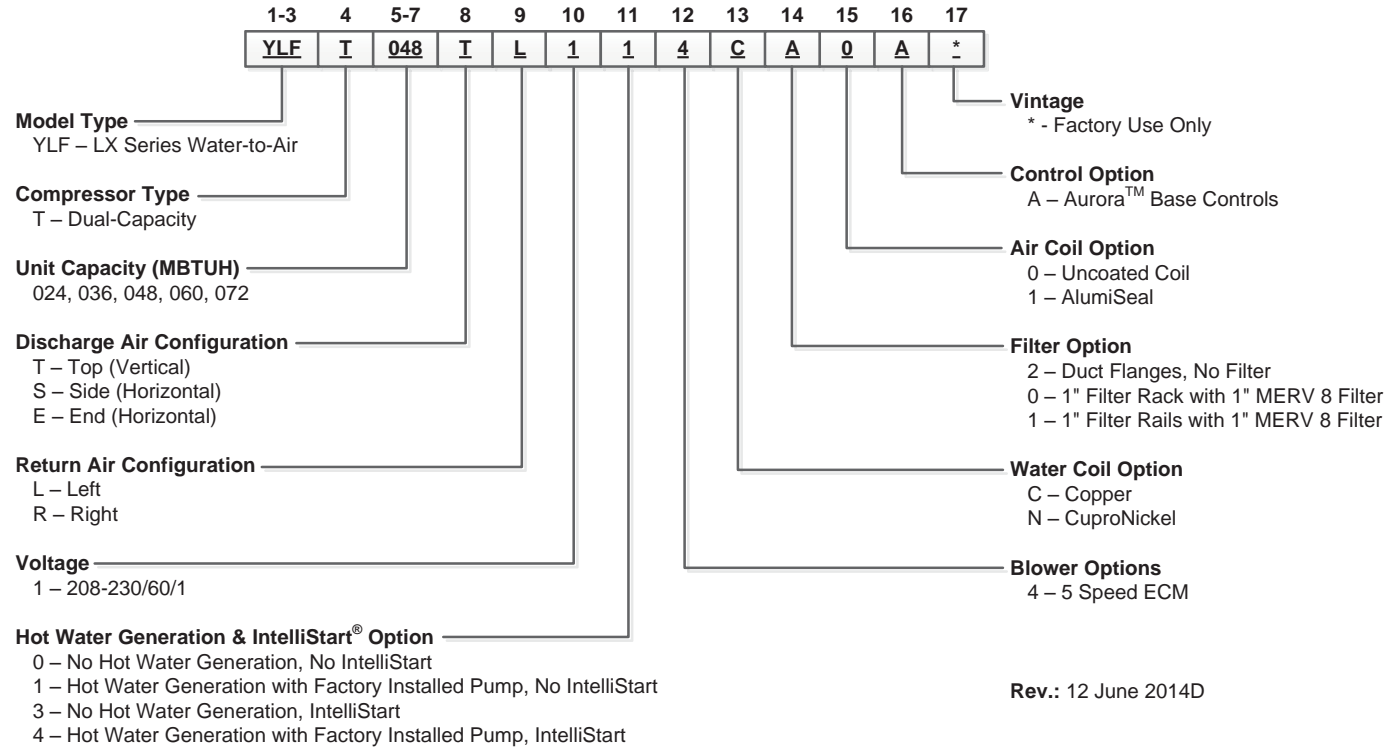

Rev.: 12 June 2014D

## General Installation Information

### Safety Considerations



**WARNING:** Before performing service or maintenance operations on a system, turn off main power switches to the indoor unit. If applicable, turn off the accessory heater power switch. Electrical shock could cause personal injury.

Installing and servicing heating and air conditioning equipment can be hazardous due to system pressure and electrical components. Only trained and qualified service personnel should install, repair or service heating and air conditioning equipment. Untrained personnel can perform the basic maintenance functions of cleaning coils and cleaning and replacing filters. All other operations should be performed by trained service personnel. When working on heating and air conditioning equipment, observe precautions in the literature, tags and labels attached to the unit and other safety precautions that may apply.

Follow all safety codes. Wear safety glasses and work gloves. Use a quenching cloth for brazing operations and have a fire extinguisher available.

### Moving and Storage

Move units in the normal “up” orientation. Horizontal units may be moved and stored per the information on the packaging. Do not stack more than three units in total height. Vertical units may be stored one upon another to a maximum height of two units. Do not attempt to move units while stacked. When the equipment is received, all items should be carefully checked against the bill of lading to be sure all crates and cartons have been received. Examine units for shipping damage, removing the units from the packaging if necessary. Units in question should also be internally inspected. If any damage is noted, the carrier should make the proper notation on the delivery receipt, acknowledging the damage.

### Unit Location

Locate the unit in an indoor area that allows for easy removal of the filter and access panels. Location should have enough space for service personnel to perform maintenance or repair. Provide sufficient room to make water, electrical and duct connection(s). If the unit is located in a confined space, such as a closet, provisions must be made for return air to freely enter the space by means of a louvered door, etc. Any access panel screws that would be difficult to remove after the unit is installed should be removed prior to setting the unit. On horizontal units, allow adequate room below the unit for a condensate drain trap and do not locate the unit above supply piping. **Care should be taken when units are located in unconditioned spaces to prevent damage from frozen water lines and excessive heat that could damage electrical components.**

### Installing Vertical Units

Prior to setting the unit in place, remove and discard the compressor hold down shipping bolt located at the front of the compressor mounting bracket.

Vertical units are available in left or right air return configurations. Top air discharge vertical units should be mounted level on a vibration absorbing pad slightly larger than the base to provide isolation between the unit and the floor. It is not necessary to anchor the unit to the floor (see below).

If access to the left side of the unit will be limited after installation, remove the two mounting screws on the left side of the control box before setting the unit (leave the two front mounting screws intact). This will allow the control box to be removed with only the two front mounting screws for future service.

Figure 1: Vertical Unit Mounting



## General Installation Information cont.

### Installing Horizontal Units

Remove and discard the compressor hold down shipping bolt located at the front of the compressor mounting bracket prior to setting the unit in place. Horizontal units are available with side or end discharge and may be easily field converted by flipping the blower discharge panel (The 024 model requires an additional discharge panel). Horizontal units are normally suspended from a ceiling by four or six 3/8 in. diameter threaded rods. The rods are usually attached to the unit by hanger bracket kits furnished with each unit.

Lay out the threaded rods per the dimensions in Figure 3. Assemble the hangers to the unit as shown. Securely tighten the brackets to the unit using the weld nuts located on the underside of the bottom panel. When attaching the hanger rods to the bracket, a double nut is required since vibration could loosen a single nut. To allow filter access, one bracket on the filter side should be installed 180° from the position shown in Figure 3. The unit should be pitched approximately 1/4-inch towards the drain in both directions to facilitate the removal of condensate. Use only the bolts provided in the kit to attach hanger brackets. The use of longer bolts could damage internal parts.

Some residential applications require the installation of horizontal units on an attic floor. In this case, the unit should be set in a full size secondary drain pan on top of a vibration absorbing pad. The secondary drain pan prevents possible condensate overflow or water leakage damage to the ceiling. The secondary drain pan is usually placed on a plywood base isolated from the ceiling joists by additional layers of vibration absorbing material.

Figure 2: Horizontal Unit Mounting

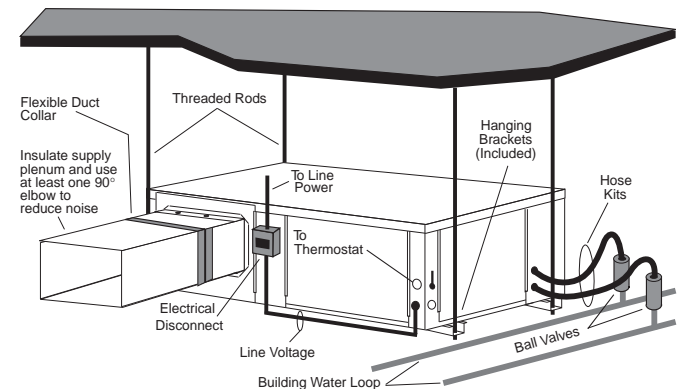

**CAUTION:** Do not use rods smaller than 3/8-inch diameter since they may not be strong enough to support the unit. The rods must be securely anchored to the ceiling.

# General Installation Information cont.

Figure 3: Hanger Location and Assembly

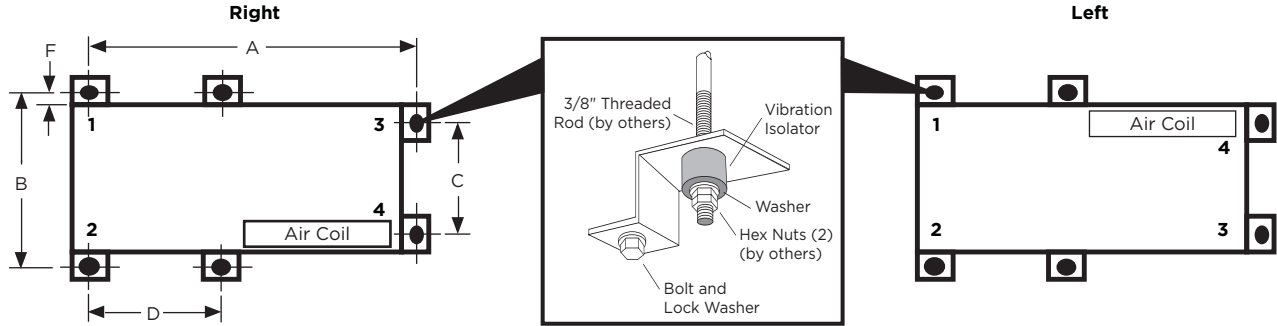

## Weight Distribution

Model		Vertical Weight	Horizontal Weight	Horizontal Weight Distribution			
				Front		Back	
				1	2	3	4
024	lb	198	228	69	63	73	23
	kg	90	103	31	29	33	10
036	lb	221	250	80	65	70	35
	kg	100	113	36	29	32	16
048	lb	303	325	93	97	101	34
	kg	137	147	42	44	46	15
060	lb	329	358	110	100	103	45
	kg	149	162	50	45	47	20
072	lb	350	369	141	78	71	79
	kg	159	167	64	35	32	36

## Hanger Bracket Locations (See Figure 3)

Model	Hanger Kit Part Number	Unit Hanger Dimensions			
		A	B	C	D
024	in.	53.7	25.1	21.4	n/a
	cm.	136.4	63.8	54.4	n/a
036	in.	63.7	25.1	21.4	n/a
	cm.	161.8	63.8	54.4	n/a
048-060	in.	72.7	28.1	24.4	29.3
	cm.	184.7	71.4	62.0	74.4
072	in.	77.7	28.1	24.4	29.3
	cm.	197.4	71.4	62.0	74.4

8/3/2014

## General Installation Information cont.

### Duct System

An air outlet collar is provided on vertical top air discharge units and all horizontal units to facilitate a duct connection. A flexible connector is recommended for discharge and return air duct connections on metal duct systems. Uninsulated duct should be insulated with a minimum of 1-inch duct insulation. Application of the unit to uninsulated ductwork in an unconditioned space is not recommended as the unit's performance will be adversely affected.

If the unit is connected to existing ductwork, check the duct system to ensure that it has the capacity to accommodate the air required for the unit application. If the duct is too small, as in the replacement of heating only systems, larger ductwork should be installed. All existing ductwork should be checked for leaks and repaired if necessary.

The duct system should be sized to handle the design airflow quietly and efficiently. To maximize sound attenuation of the unit blower, the supply and return plenums should include an internal duct liner of fiberglass or constructed of ductboard for the first few feet. On systems employing a sheet metal duct system, canvas connectors should be used between the unit and the ductwork. If air noise or excessive airflow is a problem, the blower speed can be changed.



**CAUTION:** When attaching ductwork or accessories to the cabinet, make sure the fasteners do not come into contact with the air coil.

### Water Piping

The proper water flow must be provided to each unit whenever the unit operates. To assure proper flow, use pressure/temperature ports to determine the flow rate. These ports should be located at the supply and return water connections on the unit. The proper flow rate cannot be accurately set without measuring the water pressure drop through the refrigerant-to-water heat exchanger.

All source water connections on residential units are swivel piping fittings (see Figure 4) that accept a 1-inch male pipe thread (MPT). The swivel connector has a rubber gasket seal similar to a rubber hose gasket, which when mated to the flush end of any 1-inch threaded pipe provides a leak-free seal without the need for thread sealing tape or compound. Check to ensure that the rubber seal is in the swivel connector prior to attempting any connection. The rubber seals are shipped attached to the waterline. To make the connection to a ground loop system, mate the brass connector (supplied in CK4LI connector kit) against the rubber gasket in the swivel connector and thread the female locking ring onto the pipe threads, while maintaining the brass connector in the desired direction. Tighten the connectors by hand, then gently snug the fitting with pliers to provide a leak-proof joint.

When connecting to an open loop (ground water) system, thread any 1-inch MPT fitting (SCH80 PVC or copper) into the swivel connector and tighten in the same manner as noted above. The open and closed loop piping system should include pressure/temperature taps for serviceability.

Never use flexible hoses smaller than 1-inch inside diameter on the unit. Limit hose length to 10 feet per connection. Check carefully for water leaks.

**Figure 4: Swivel Connections**

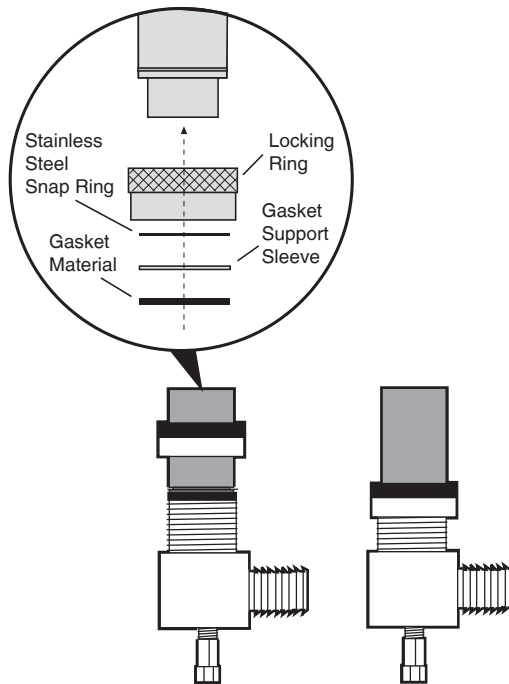



---

## General Installation Information cont.

---

### Water Quality

It is the responsibility of the system designer and installing contractor to ensure that acceptable water quality is present and that all applicable codes have been met in these installations. Failure to adhere to the guidelines in the water quality table could result in loss of warranty. In ground water situations where scaling could be heavy or where biological growth such as iron bacteria will be present, a closed loop system is recommended. The heat exchanger coils in ground water systems may, over a period of time, lose heat exchange capabilities due to a buildup of mineral deposits inside. These can be cleaned, but only by a qualified service mechanic, as special solutions and pumping equipment are required. Hot water generator coils can likewise become scaled and possibly plugged. In areas with extremely hard water, the owner should be informed that the heat exchanger may require occasional flushing.

Units with cupronickel heat exchangers are recommended for open loop applications due to the increased resistance to build-up and corrosion, along with reduced wear caused by acid cleaning. Failure to adhere to the guidelines in the water quality table could result in the loss of warranty.

### Water Treatment

Do not use untreated or improperly treated water. Equipment damage may occur. The use of improperly treated or untreated water in this equipment may result in scaling, erosion, corrosion, algae or slime. Purchase of a pre-mix antifreeze could significantly improve system reliability if the water quality is controlled and there are additives in the mixture to inhibit corrosion. There are many examples of such fluids on the market today such as Environol™ 1000 (pre-mix ethanol), and others. The services of a qualified water treatment specialist should be engaged to determine what treatment, if any, is required. The product warranty specifically excludes liability for corrosion, erosion or deterioration of equipment.

The heat exchangers and water lines in the units are copper or cupronickel tube. There may be other materials in the buildings piping system that the designer may need to take into consideration when deciding the parameters of the water quality. If antifreeze or water treatment solution is to be used, the designer should confirm it does not have a detrimental effect on the materials in the system.

### Contaminated Water

In applications where the water quality cannot be held to prescribed limits, the use of a secondary or intermediate heat exchanger is recommended to separate the unit from the contaminated water. The table on the next page outlines the water quality guidelines for unit heat exchangers. If these conditions are exceeded, a secondary heat exchanger is required. Failure to supply a secondary heat exchanger where needed will result in a warranty exclusion for primary heat exchanger corrosion or failure.

# General Installation Information cont.

## Water Quality Guidelines

Material		Copper	90/10 Cupro-Nickel	316 Stainless Steel
pH	Acidity/Alkalinity	7- 9	7 - 9	7 - 9
Scaling	Calcium and Magnesium Carbonate	(Total Hardness) less than 350 ppm	(Total Hardness) less than 350 ppm	(Total Hardness) less than 350 ppm
Corrosion	Hydrogen Sulfide	Less than .5 ppm (rotten egg smell appears at 0.5 PPM)	10 - 50 ppm	Less than 1 ppm
	Sulfates	Less than 125 ppm	Less than 125 ppm	Less than 200 ppm
	Chlorine	Less than .5 ppm	Less than .5 ppm	Less than .5 ppm
	Chlorides	Less than 20 ppm	Less than 125 ppm	Less than 300 ppm
	Carbon Dioxide	Less than 50 ppm	10 - 50 ppm	10- 50 ppm
	Ammonia	Less than 2 ppm	Less than 2 ppm	Less than 20 ppm
	Ammonia Chloride	Less than .5 ppm	Less than .5 ppm	Less than .5 ppm
	Ammonia Nitrate	Less than .5 ppm	Less than .5 ppm	Less than .5 ppm
	Ammonia Hydroxide	Less than .5 ppm	Less than .5 ppm	Less than .5 ppm
	Ammonia Sulfate	Less than .5 ppm	Less than .5 ppm	Less than .5 ppm
	Total Dissolved Solids (TDS)	Less than 1000 ppm	1000-1500 ppm	1000-1500 ppm
	LSI Index	*0.5 to :.05	*0.5 to :.05	*0.5 to :.05
Iron Fouling (Biological Growth)	Iron, Fe <sup>2+</sup> (Ferrous) Bacterial Iron Potential	< .2ppm	< .2 ppm	< .2 ppm
	Iron Oxide	Less than 1 ppm. Above this level deposition will occur.	Less than 1 ppm. Above this level deposition will occur.	Less than 1 ppm. Above this level deposition will occur.
Erosion	Suspended Solids	Less than 10 ppm and filtered for max of 600 micron size	Less than 10 ppm and filtered for max of 600 micron size	Less than 10 ppm and filtered for max of 600 micron size
	Threshold Velocity (Fresh Water)	< 6 ft/sec	< 6 ft/sec	<6 ft/sec

NOTE: Grains = PPM divided by 17 • mg/l is equivalent to PPM

7/17/14

## Low Water Coil Limit

Set the freeze sensing switch SW2-1 on the Aurora Base Control (ABC) printed circuit board for applications using a closed loop antifreeze solution to "LOOP" (15°F). On applications using an open loop/ground water system (or closed loop no antifreeze), set this dip switch to "WELL" (30°F), the factory default setting. (Refer to the DIP Switch Settings table in the Aurora Control section.)

## Condensate Drain

On vertical units, the internal condensate drain assembly consists of a drain tube which is connected to the drain pan, a 3/4-inch PVC female adapter and a flexible connecting hose. The female adapter may exit either the front or the side of the cabinet. The adapter should be glued to the field-installed PVC condensate piping. On vertical units, a condensate hose is inside all cabinets as a trapping loop; therefore, an external trap is not necessary.

On horizontal units, a PVC stub is provided for condensate drain piping connection. An external trap is required (see below). If a vent is necessary, an open stand pipe may be applied to a tee in the field-installed condensate piping.

Figure 5: Horizontal Drain Connection

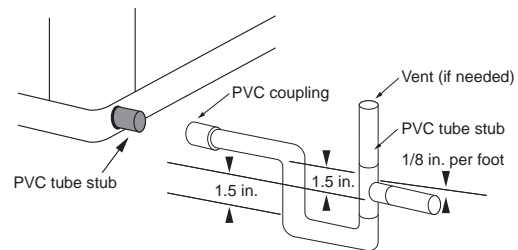

NOTE: Check dimensional data for actual PVC sizes.

Figure 6: Unit Pitch for Drain

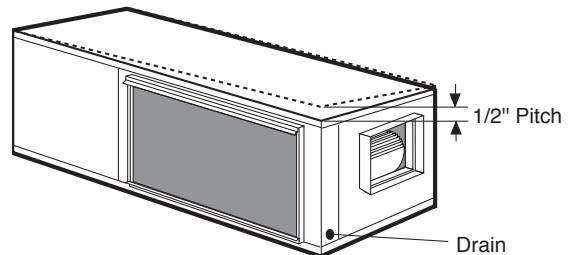

## Closed Loop Ground Source Systems

Once piping is completed between the unit, pumps and the ground loop, final purging and charging of the loop is required. A flush cart (or a 1.5 HP pump minimum) is needed to achieve adequate flow velocity in the loop to purge air and dirt particles from the loop itself. A filter **MUST** be used when flushing a loop. The standard 100 micron filter bag (LFC-F100M) is acceptable for capturing relatively large debris such as pipe shavings, gravel, and medium sand particles. In certain installation locations other smaller materials such as fine sand, silt, and clay can be less than 75 microns. For these smaller particles the use of the 1 micron filter bag is required (LFC-F1M). It is also recommended to run the flush cart with the 1 micron filter bag for at least 30 minutes. Antifreeze solution is used in most areas to prevent freezing. Flush the system adequately to remove as much air as possible then pressurize the loop to a static pressure of 40-50 psi (summer) or 50-75 psi (winter). This is normally adequate for good system operation. Loop static pressure will fluctuate with the seasons. Pressures will be higher in the winter months than during the cooling season. This fluctuation is normal and should be considered when initially charging the system.

**Figure 7: Closed Loop Ground Source Application**

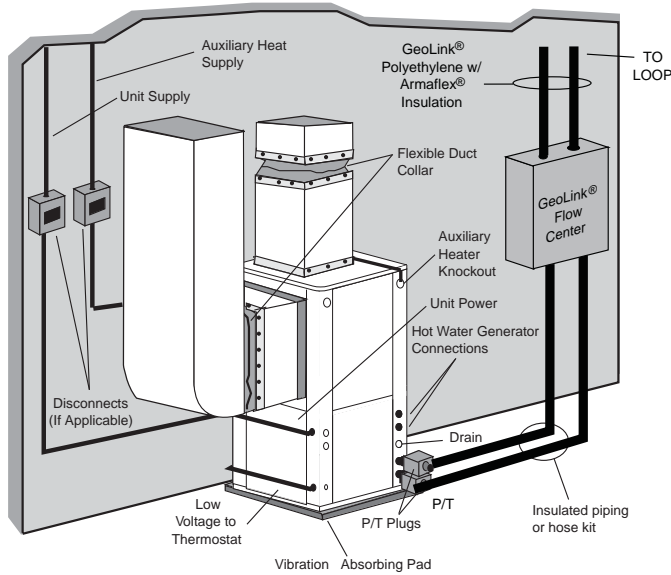

**NOTE:** Additional information can be found in Flow Center installation manual and Flush Cart manual.

## Multiple Units on One Flow Center

When two heat pumps are connected to one loop pumping system, follow figure 8. Installer will be required to supply fuses, two relays, and wiring. It is recommended that water solenoid valves be installed on heat pumps that share a flow center. This is to allow water flow through only the heat pump that has a demand. Circulating fluid through a heat exchanger of a system that is not operating could be detrimental to the long-term reliability of the compressor.

**Figure 8: Primary/Secondary Wiring with Aurora Base Control (no AXB Board)**

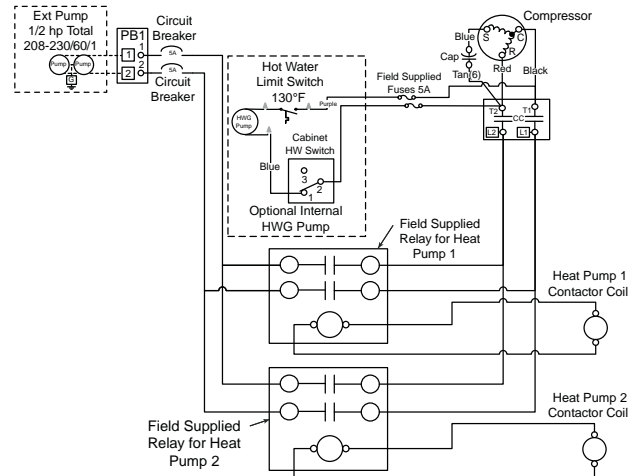

## Open Loop Ground Water Systems

Typical open loop piping is shown below. Always maintain water pressure in the heat exchanger by placing water control valves at the outlet of the unit to prevent mineral precipitation. Use a closed, bladder-type expansion tank to minimize mineral formation due to air exposure. Ensure proper water flow through the unit by checking pressure drop across the heat exchanger and comparing it to the figures in unit capacity data tables in the specification catalog. 1.5-2 gpm of flow per ton of cooling capacity is recommended in open loop applications.

**Figure 9a: Open Loop Solenoid Valve Connection Option**

Typical quick operating external 24V water solenoid valve (type PPV100 or BPV100) wiring.

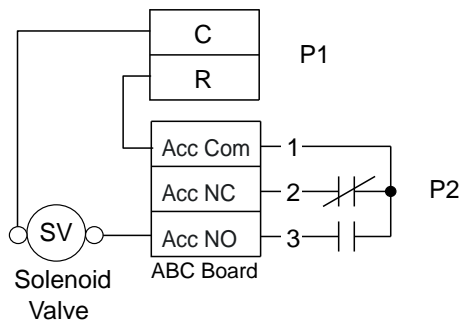

**NOTE:** SW2-4 and SW2-5 should be "OFF" to cycle with the compressor.

**Figure 10: Open System - Groundwater Application**

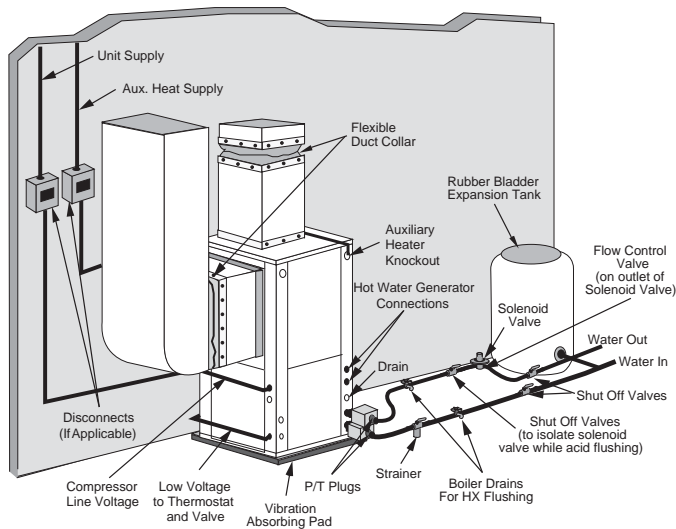

Discharge water from the unit is not contaminated in any manner and can be disposed of in various ways, depending on local codes, i.e. recharge well, storm sewer, drain field, adjacent stream or pond, etc. Most local codes forbid the use of sanitary sewer for disposal. Consult your local building and zoning departments to assure compliance in your area.

**NOTE:** For open loop/groundwater systems or systems that do not contain an antifreeze solution, set SW2-Switch #1 to the "WELL" (30°F) position. (Refer to the DIP Switch Settings table in the Aurora Control section.) Slow opening/closing solenoid valves (type V) are recommended to eliminate water hammer.

**Figure 9b: Open Loop Solenoid Valve Connection Option**

Typical slow operating external 24V water solenoid valve (type V) wiring.

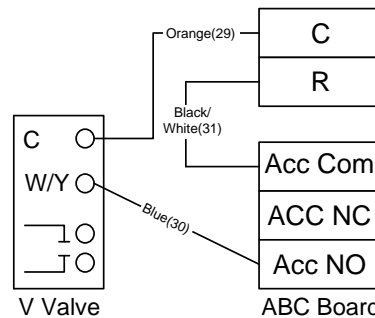

**NOTE:** SW2-4 should be "ON" and SW2-5 should be "OFF" when using a slow opening (V) water valve.

**Figure 9c: Wiring diagram for dual water valve installations, one type V slow operating solenoid and one BPV100/PPV100 quick operating solenoid.**

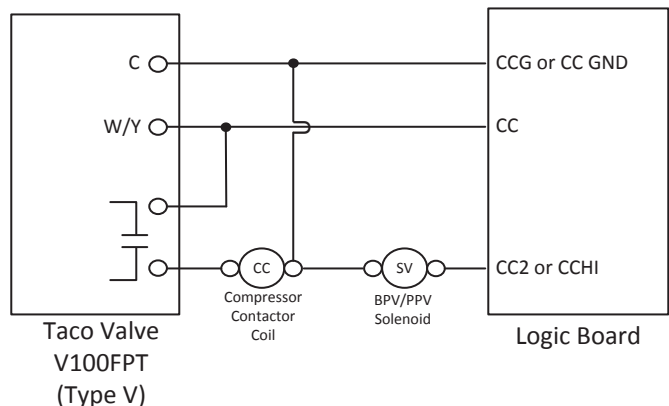

## Hot Water Generator Connections

To maximize the benefits of the hot water generator a minimum 50-gallon water heater is recommended. For higher demand applications, use an 80-gallon water heater or two 50-gallon water heaters connected in a series as shown below. Two tanks plumbed in a series is recommended to maximize the hot water generator capability. Electric water heaters are recommended. Make sure all local electrical and plumbing codes are met for installing a hot water generator. Residential units with hot water generators contain an internal circulator and fittings. A water softener is recommended with hard water (greater than 10 grains or 170 total hardness).

**NOTES:** 1) Using a preheat tank, as shown in Figure 12, will maximize hot water generator capabilities. 2) The hot water generator coil is constructed of vented double wall copper suitable for potable water.

### Water Tank Preparation

To install a unit with a hot water generator, follow these installation guidelines.

1. Turn off the power to the water heater.
2. Attach a water hose to the water tank drain connection and run the other end of the hose to an open drain or outdoors.
3. Close the cold water inlet valve to the water heater tank.
4. Drain the tank by opening the valve on the bottom of the tank, then open the pressure relief valve or hot water faucet.
5. Flush the tank by opening the cold water inlet valve to the water heater to free the tank of sediments. Close when draining water is clear.
6. Disconnect the garden hose and remove the drain valve from the water heater.
7. Refer to Plumbing Installation and Hot Water Generator Startup.



**CAUTION:** Elements will burn out if energized dry.

**Figure 11: Typical Hot Water Generator Installation**

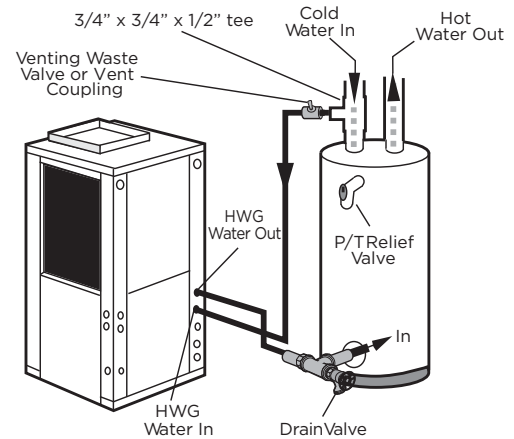

**Figure 12: Hot Water Generator Installation In Preheat Tank**

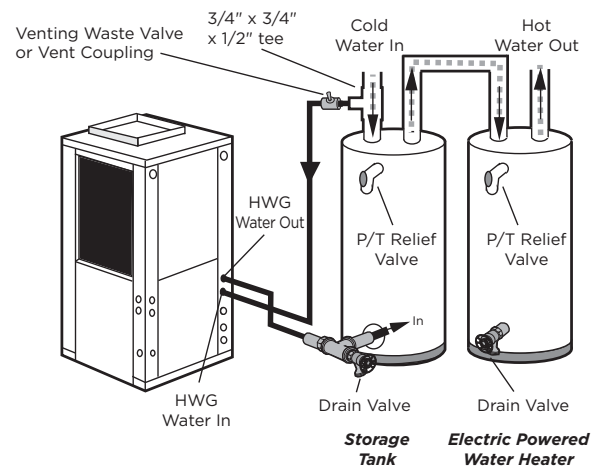

**NOTE:** This configuration maximizes hot water generator capability.

## Hot Water Generator Connections cont.

### Plumbing Installation

1. Inspect the dip tube in the water heater cold inlet for a check valve. If a check valve is present it must be removed or damage to the hot water generator circulator will occur.
2. Remove drain valve and fitting.
3. Thread the 3/4-inch NPT x 3-1/2-inch brass nipple into the water heater drain port.
4. Attach the center port of the 3/4-inch FPT tee to the opposite end of the brass nipple.
5. Attach the 1/2-inch copper to 3/4-inch NPT adaptor to the side of the tee closest to the unit.
6. Install the drain valve on the tee opposite the adaptor.
7. Run interconnecting tubing from the tee to hot water generator water out.
8. Cut the cold water "IN" line going to the water heater.
9. Insert the reducing solder tee in line with cold water "IN" line as shown.
10. Run interconnecting copper tubing between the unit hot water generator water "IN" and the tee (1/2-inch nominal). The recommended maximum distance is 50 feet.
11. To prevent air entrapment in the system, install a vent coupling at the highest point of the interconnecting lines.
12. Insulate all exposed surfaces of both connecting water lines with 3/8-inch wall closed cell insulation.

**NOTE:** All plumbing and piping connections must comply with local plumbing codes.

### Hot Water Generator Switch

The hot water generator switch is taped in the disabled position at the factory.

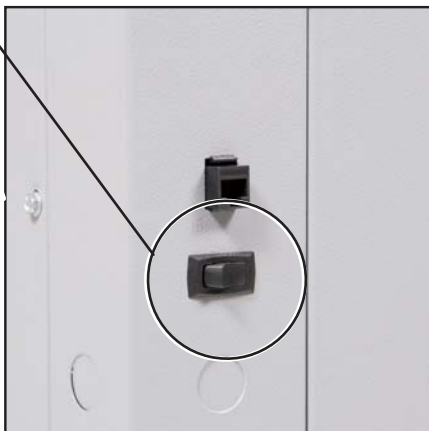

### Hot Water Generator Startup

1. Turn the hot water generator switch to the "ON" position. The hot water generator switch will allow the hot water generator pump to be enabled or disabled by the service technician or homeowner.
2. Close the drain valve to the water heater.
3. Open the cold water supply to the tank.
4. Open a hot water faucet in the building to bleed air from the system. Close when full.
5. Open the pressure relief valve to bleed any remaining air from the tank, then close.
6. If so equipped, turn the venting (burping) screw in the center of the pump two (2) turns open (water will drip out), wait until all air is purged from the pump, then tighten the plug. Use vent couplings to bleed air from the lines.
7. Carefully inspect all plumbing for water leaks and correct as required.
8. Before restoring electrical supply to the water heater, adjust the temperature setting on the tank.
  - On tanks with both upper and lower elements, the lower element should be turned down to the lowest setting, approximately 100°F. The upper element should be adjusted to 120°F to 130°F. Depending upon the specific needs of the customer, you may want to adjust the upper element differently.
  - On tanks with a single element, lower the thermostat setting to 120°F.
9. After the thermostat(s) is adjusted, replace the access cover and restore electrical supply to the water heater.
10. Make sure that any valves in the hot water generator water circulating circuit are open.
11. Turn on the unit to first stage heating.
12. The hot water generator pump should be running. When the pump is first started, turn the venting (burping) screw located under the Burp Me label (if equipped) in the center of the pump two (2) turns open until water dribbles out, then retighten venting screw. Allow the pump to run for at least five minutes to ensure that water has filled the circulator properly. Be sure the switch for the hot water generator pump switch is "ON".
13. The temperature difference between the water entering and leaving the hot water generator should be 5°F to 15°F. The water flow should be approximately 0.4 gpm per ton of nominal cooling.
14. Allow the unit to heat water for 15 to 20 minutes to be sure operation is normal.



**CAUTION:** Never operate the HWG circulating pump while dry. If the unit is placed in operation before the hot water generator piping is connected, be sure that the pump switch is set to the OFF position.



# Electrical Connections

## General

Be sure the available power is the same voltage and phase as that shown on the unit serial plate. Line and low voltage wiring must be done in accordance with local codes or the National Electric Code, whichever is applicable.

## Unit Power Connection

Connect the incoming line voltage wires to L1 and L2 of the contactor as shown in Figure 13B for single-phase unit. Consult the Unit Electrical Data in this manual for correct fuse sizes.

Open lower front access panel. Insert power wires through knockouts on lower left side of cabinet. Route wires through left side of control box and connect to contactor and ground (Figure 13B).

## Accessory Relay

A set of “dry” contacts has been provided to control accessory devices, such as water solenoid valves on open loop installations, electronic air cleaners, humidifiers, etc. This relay contact should be used only with 24 volt signals and not line voltage power. The relay has both normally open and normally closed contacts and can operate with either the fan or the compressor. Use DIP switch SW2-4 and 5 to cycle the relay with blower, compressor, or control a slow opening water valve. The relay contacts are available on terminals #1 and #3 of P2.

## 208 Volt Operation

All 208/230 units are factory wired for 230 volt operation. For 208 volt operation, the red and blue transformer wires must be switched on terminal strip PB2.

**Figure 13B:**  
Line Voltage 208-230/60/1 control box

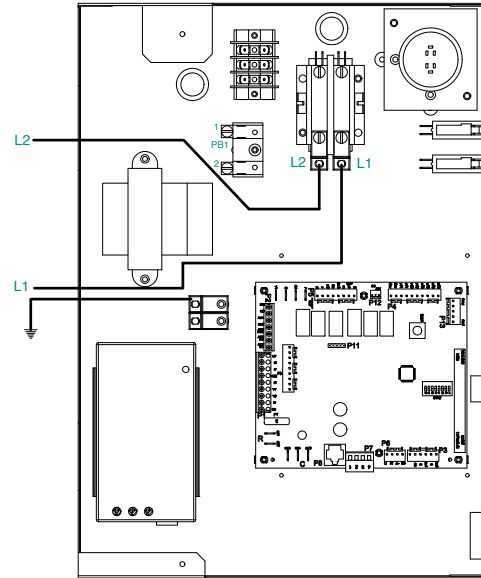

## Pump Power Wiring

See Figure 14 for electrical connections from control box to pumps.

FC1/FC2 style flow centers with fixed speed pumps connect to PB1 in the control box.

**Figure 14: Pump Wiring 208-230/60/1**

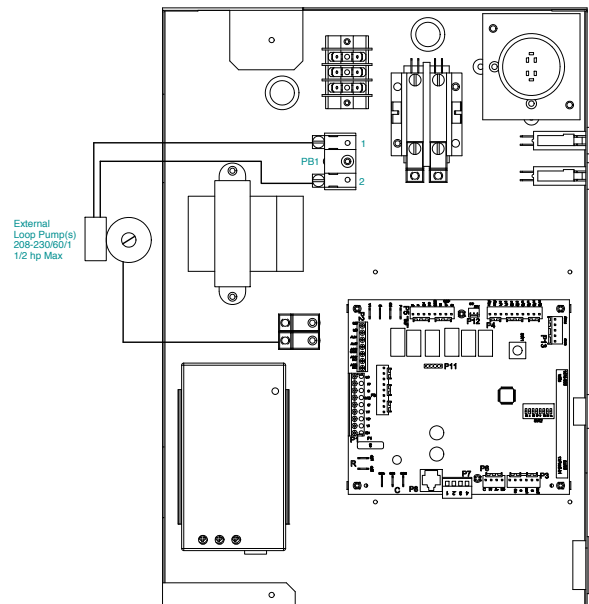

**Figure 13A:**  
Wire access

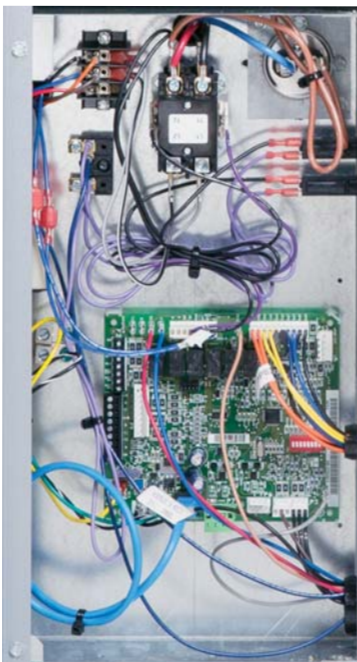

## Electronic Thermostat Installation

Position the thermostat subbase against the wall so that it is level and the thermostat wires protrude through the middle of the subbase. Mark the position of the subbase mounting holes and drill holes with a 3/16-inch bit. Install supplied anchors and secure base to the wall. Thermostat wire must be 8-conductor (4 or 5 conductor for communicating thermostats), 20-AWG (minimum) wire. Strip the wires back 1/4-inch (longer strip lengths may cause shorts) and insert the thermostat wires into the connector as shown. Tighten the screws to ensure secure connections. The thermostat has the same type connectors, requiring the same wiring. See instructions enclosed in the thermostat for detailed installation and operation information. The W1 terminal on TPCM32U03AYRK and TPCM32U04AYRK communicating thermostats may be hard wired to provide aux/emergency heat in the event communication is lost between the thermostat and the ABC microprocessor.

**NOTE:** Aurora Base Control (ABC) DIP switch SW2-7 is required to be in the "OFF" position for the control to operate with FaultFlash or ComforTalk thermostats. SW2-7 in the "ON" position configures the control to operate with typical thermostats (continuous lockout signal). There must be a wire connecting Y2 on the Aurora controller to 2nd stage compressor on the thermostat for proper operation. SW2-7 DIP switch position is not relevant with communicating thermostats.

Figure 15a: Thermostat Wiring (Y1 Style Signals)

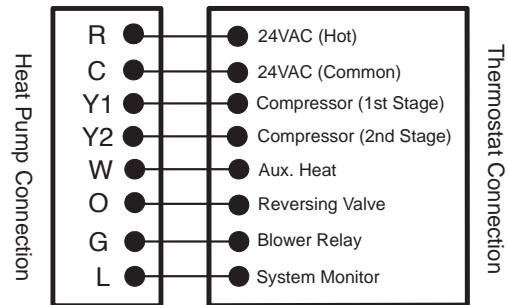
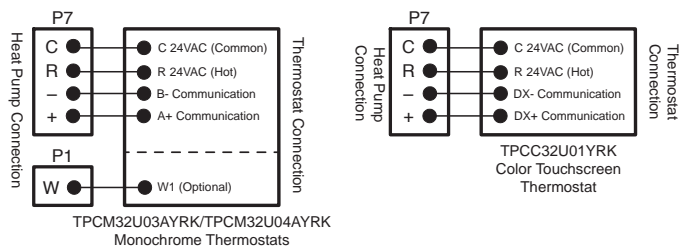

Figure 15b: Thermostat Wiring (Communicating Style Signals)





## Auxiliary Heat Ratings

Model	KW		Stages	BTU/HR		Min CFM			
	208V	230V		208V	230V		024	036	048 - 072
EAM(H)5*	3.6	4.8	1	12,300	16,300	450	●	●	
EAM(H)8*	5.7	7.6	2	19,400	25,900	550	●	●	
EAM(H)10*	7.2	9.6	2	24,600	32,700	650	●	●	
EAL(H)10*	7.2	9.6	2	24,600	32,700	1100			●
EAL(H)15*	10.8	14.4	2	36,900	49,100	1250			●
EAL(H)20*	14.4	19.2	2	49,200	65,500	1500			●

Order the "H" part number when installed on horizontal units

6/9/2014

Air flow level for auxiliary heat (Aux) must be equal to or above the minimum CFM in this table

## Auxiliary Heat Electrical Data

Model	Supply Circuit	Heater Amps		Min Circuit Amp		Fuse (USA)		Fuse (CAN)		CKT BRK	
		208 V	240 V	208 V	240 V	208 V	240 V	208 V	240 V	208 V	240 V
EAM(H)5*	Single	17.3	20.0	26.7	30.0	30	30	30	30	30	30
EAM(H)8*	Single	27.5	31.7	39.3	44.6	40	45	40	45	40	45
EAM(H)10*	Single	34.7	40.0	48.3	55.0	50	60	50	60	50	60
EAL(H)10*	Single	34.7	40.0	53.3	60.0	60	60	60	60	60	60
EAL(H)15*	Single	52.0	60.0	75.0	85.0	80	90	80	90	70	100
	L1/L2	34.7	40.0	53.3	60.0	60	60	60	60	60	60
	L3/L4	17.3	20.0	21.7	25.0	25	25	25	25	20	30
EAL(H)20*	Single	69.3	80.0	96.7	110.0	100	110	100	110	100	100
	L1/L2	34.7	40.0	53.3	60.0	60	60	60	60	60	60
	L3/L4	34.7	40.0	43.3	50.0	45	50	45	50	40	50

All heaters rated single phase 60 cycle and include unit fan load

3/10/14

All fuses type "D" time delay (or HACR circuit breaker in USA)

Supply wire size to be determined by local codes

## Electrical Data

### Dual Capacity Unit with 5 Speed ECM Motor

Model	Rated Voltage	Voltage Min/Max	Compressor				HWG Pump FLA	Ext Loop FLA	Blower Motor FLA	Total Unit FLA	Min Circ Amp	Max Fuse/HACR
			MCC	RLA	LRA	LRA**						
024	208-230/60/1	187/253	18.2	11.6	58.3	21.0	0.4	5.4	4.1	21.5	24.5	35
036	208-230/60/1	187/253	23.8	15.2	83.0	30.0	0.4	5.4	4.1	25.1	28.9	40
048	208-230/60/1	187/253	33.0	21.1	104.0	37.0	0.4	5.4	7.6	34.5	39.8	60
060	208-230/60/1	187/253	42.3	27.1	152.9	54.0	0.4	5.4	7.6	40.5	47.2	70
072	208-230/60/1	187/253	46.3	29.6	179.2	63.0	0.4	5.4	7.6	43.0	50.4	80

\*\*With optional IntelliStart

Rated Voltage of 208/230/60/1

HACR circuit breaker in USA only

All fuses Class RK-5

6/9/14

# Blower Performance Data

## 5-Speed ECM Constant Torque Motors

The 5-Speed ECM is a 'Constant Torque' ECM motor and delivers air flow similar to a PSC but operates as efficiently as an ECM Motor. Because it's an ECM Motor, the 5-Speed ECM can ramp slowly up or down like the ECM motor. There are 5 possible speed taps available on the 5-Speed ECM motor with #1 being the lowest airflow and #5 being the highest airflow. These speed selections are preset at the time of manufacture and are easily changed in the field if necessary.

If more than one tap are energized at the same time, built in logic gives precedence to the highest tap number and allows air flow to change with G, Y1, Y2 and W signals or with Fan, CC, CC2, and E1 output signals. Each of those 5 speeds has a specific 'Torque' value programmed into the motor for each speed selection.

As static pressure increases, airflow decreases resulting in less torque on the rotor. The motor responds only to changes in torque and adjusts its speed accordingly.

The 5-Speed ECM motor is powered by line voltage but the motor speed is energized by 24 VAC.

### 5-Speed ECM Benefits:

- High efficiency
- Soft start
- 5 speeds with up to 4 speeds on-line
- Built in logic allows air flow to change with G, Y1, Y2 and W signals
- Super efficient low airflow continuous blower setting (G)

## Dual Capacity with 5-Speed ECM

Model	Motor Speed	Motor Tap	T'stat Cnct.	Blower Size	Motor HP	Airflow (cfm) at External Static Pressure (in. wg)															
						0	0.05	0.1	0.15	0.2	0.25	0.3	0.35	0.4	0.45	0.5	0.6	0.7	0.8	0.9	1.00
024	<b>High</b>	<b>5</b>	W	9 x 7	1/2	1024	1013	1002	988	974	963	951	940	929	901	872	785	691	-	-	-
	<b>Med High</b>	<b>4</b>	Y2			932	917	902	892	882	867	851	842	832	817	802	756	661	-	-	-
	Med	3				835	826	816	801	785	772	759	749	738	719	700	677	636	-	-	-
	<b>Med Low</b>	<b>2</b>	Y1			765	747	729	720	710	696	681	662	643	627	611	581	515	-	-	-
	<b>Low</b>	<b>1</b>	G			665	656	647	626	605	593	580	561	541	519	496	443	392	-	-	-
036	<b>High</b>	<b>5</b>	W	9 x 7	1/2	1325	1319	1313	1293	1272	1242	1212	1158	1103	1058	1013	930	839	-	-	-
	<b>Med High</b>	<b>4</b>	Y2			1279	1267	1254	1238	1222	1203	1184	1137	1089	1049	1008	926	836	-	-	-
	Med	3				1229	1218	1206	1187	1167	1154	1140	1110	1079	1044	1008	929	829	-	-	-
	<b>Med Low</b>	<b>2</b>	Y1			1201	1184	1167	1156	1145	1129	1113	1086	1058	1028	997	914	808	-	-	-
	<b>Low</b>	<b>1</b>	G			1007	989	971	958	945	925	904	889	873	862	850	818	778	-	-	-
048	<b>High</b>	<b>5</b>	W	11 x 10	1	1890	1874	1857	1845	1833	1809	1784	1769	1754	1736	1718	1672	1629	1601	1562	1522
	<b>Med High</b>	<b>4</b>	Y2			1769	1754	1739	1721	1703	1685	1666	1645	1623	1604	1585	1539	1499	1463	1432	1376
	Med	3				1671	1652	1632	1614	1595	1576	1557	1536	1514	1494	1474	1430	1387	1351	1313	1173
	<b>Med Low</b>	<b>2</b>	Y1			1574	1555	1535	1514	1492	1472	1452	1431	1410	1387	1363	1330	1284	1236	1108	1014
	<b>Low</b>	<b>1</b>	G			1388	1370	1352	1322	1292	1264	1236	1216	1195	1178	1161	1095	984	916	842	787
060	<b>High</b>	<b>5</b>	W	11 x 10	1	2077	2066	2055	2044	2033	2017	2000	1966	1931	1904	1877	1841	1810	1791	1740	1653
	<b>Med High</b>	<b>4</b>	Y2			1948	1937	1925	1910	1895	1880	1865	1831	1797	1778	1759	1720	1707	1680	1660	1612
	Med	3				1810	1794	1778	1739	1700	1684	1667	1657	1646	1629	1612	1576	1583	1547	1510	1480
	<b>Med Low</b>	<b>2</b>	Y1			1680	1667	1653	1618	1583	1562	1540	1522	1503	1488	1473	1465	1449	1410	1369	1319
	<b>Low</b>	<b>1</b>	G			1594	1572	1550	1512	1474	1450	1426	1410	1393	1385	1376	1351	1325	1290	1168	1085
072	<b>High</b>	<b>5</b>	W	11 x 10	1	2402	2388	2373	2358	2343	2334	2325	2307	2289	2274	2258	2215	2177	2125	2052	1933
	<b>Med High</b>	<b>4</b>	Y2			2209	2193	2177	2164	2151	2135	2118	2105	2092	2072	2052	2017	1982	1954	1925	1844
	Med	3				2085	2072	2058	2045	2031	2010	1989	1972	1954	1936	1918	1881	1852	1821	1790	1751
	<b>Med Low</b>	<b>2</b>	Y1			1961	1951	1940	1926	1911	1885	1859	1844	1829	1814	1798	1759	1727	1703	1670	1636
	<b>Low</b>	<b>1</b>	G			1767	1751	1735	1715	1694	1678	1661	1640	1619	1602	1584	1548	1512	1475	1426	1397

Factory speed settings are in Bold

7/30/14

Air flow values are with dry coil and standard filter

For wet coil performance first calculate the face velocity of the air coil (Face Velocity [fpm] = Airflow [cfm] / Face Area [sq ft]).

Then for velocities of 200 fpm reduce the static capability by 0.03 in. wg, 300 fpm by 0.08 in. wg, 400 fpm by 0.12 in. wg., and 500 fpm by 0.16 in. wg.

Highest setting is for auxiliary heat (W) and lowest setting is for constant blower (G). The "Y1" and "Y2" settings must be between the "G" and "W" settings.

## Setting Blower Speed - 5-Speed-ECM

5-Speed ECM blower motors have five (5) speeds of which four (4) are selectable on dual capacity.

## 5-Speed ECM Motor Connections - Dual Capacity



**CAUTION: Disconnect all power before performing this operation.**

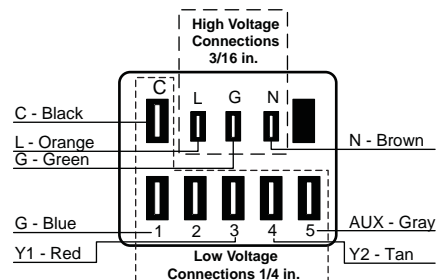

# Vertical Dimensional Data

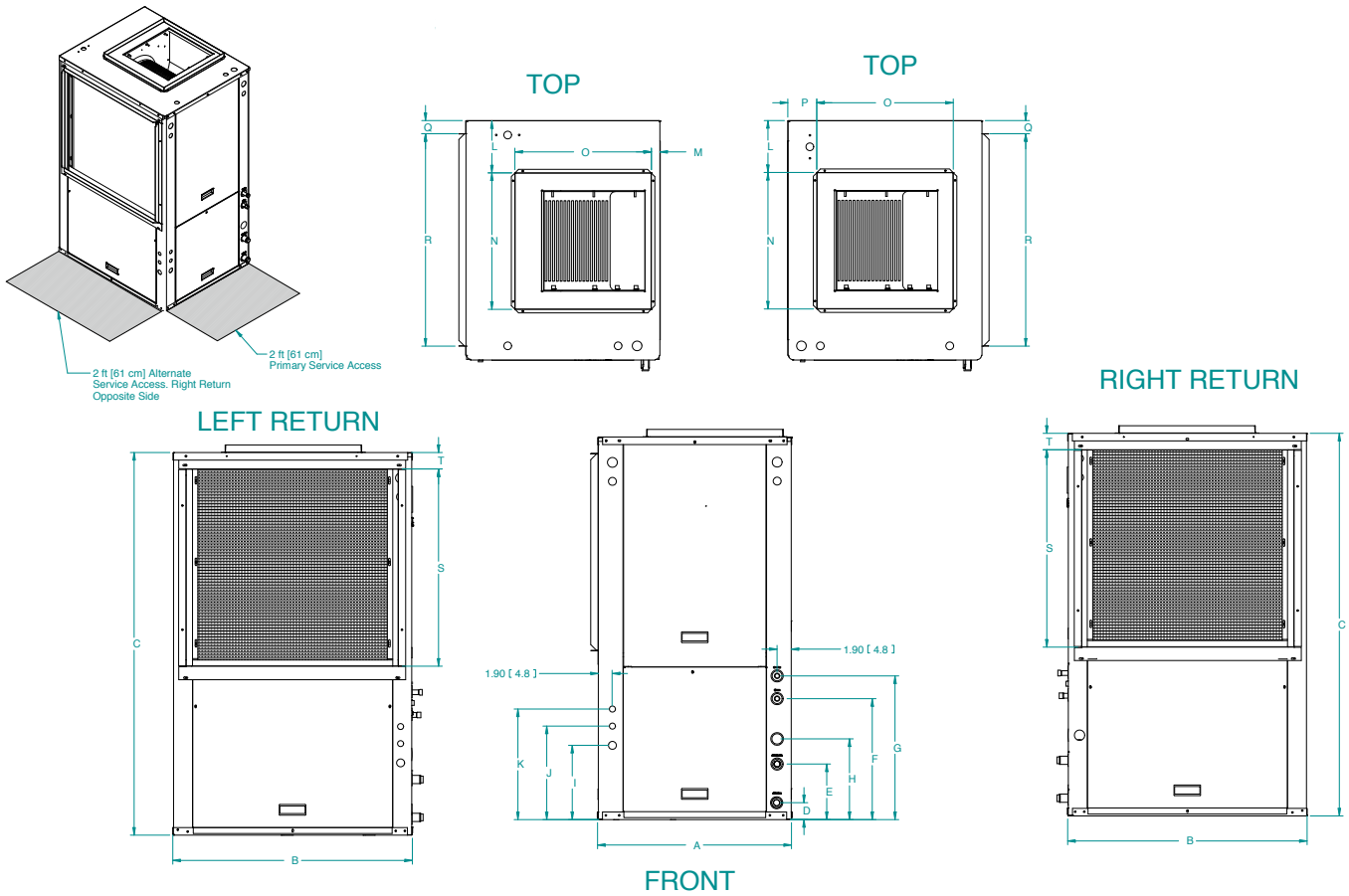

Vertical Top Flow Model	Overall Cabinet			Water Connections							Electrical Connections			Discharge Connection					Return Connection				
	A	B	C	D	E	F	G	H	Loop Water FPT	HWG Sweat (I.D.)	I	J	K	Duct Flange Installed					Return Duct Flanges				
											3/4" cond	1/2" cond	1/2" cond	L	M	N	O	P	Q	R	S	T	
	Width	Depth	Height	Loop In	Loop Out	HWG In	HWG Out	Condensate	Power Supply	Ext Pump	Low Voltage	Supply Width	Supply Depth	Return Depth	Return Height								
024	in.	22.5	26.5	39.4	2.3	5.3	13.4	16.4	9.6	1"	1/2"	8.9	11.4	13.7	6.3	0.7	14.0	14.0	2.7	2.3	22.0	18.0	1.8
	cm.	57.2	67.3	100.1	5.8	13.5	34.0	41.7	24.4	Swivel	female	22.6	29.0	34.8	16.0	1.8	35.6	35.6	6.9	5.8	55.9	45.7	4.6
036	in.	22.5	26.5	44.5	2.0	7.0	13.5	16.5	10.2	1"	1/2"	9.5	12.1	14.3	6.1	0.8	14.0	14.0	4.4	2.4	22.0	22.0	2.0
	cm.	57.2	67.3	113.0	5.1	17.8	34.3	41.9	25.9	Swivel	female	24.1	30.7	36.3	15.5	2.0	35.6	35.6	11.2	6.1	55.9	55.9	5.1
048- 060	in.	25.6	31.6	50.4	2.3	7.3	15.9	18.9	10.6	1"	1/2"	9.8	12.3	14.6	6.9	1.1	18.0	18.0	3.8	1.7	28.0	26.0	1.7
	cm.	65.0	80.3	128.0	5.8	18.5	40.4	48.0	26.9	Swivel	female	24.9	31.2	37.1	17.5	2.8	45.7	45.7	9.7	4.3	71.1	66.0	4.3
072	in.	25.6	31.6	54.4	2.3	7.3	15.9	18.9	10.6	1"	1/2"	9.8	12.3	14.6	6.9	1.1	18.0	18.0	3.8	1.7	28.1	30.0	2.2
	cm.	65.0	80.3	138.2	5.8	18.5	40.4	48.0	26.9	Swivel	female	24.9	31.2	37.1	17.5	2.8	45.7	45.7	9.7	4.3	71.4	76.2	5.6

Condensate is 3/4" PVC female glue socket and is switchable from side to front  
 Unit shipped with 1" [25.4mm] return duct flanges and are suitable for duct connection.  
 Discharge flange is field installed and extends 1" [25.4mm] from cabinet  
 Water connections extend 1.2" [30.5mm] beyond front of cabinet.  
 The optional 1" filter rack (not shown) has the same return opening connection size as the duct flanges shown in the drawing. The filter rack extends 2.25"(57.1 mm) from the unit.  
 The optional 1" filter rack is suitable for duct connection.  
 The optional filter rails (not shown) extend 1.25" (31.75 mm) from cabinet.

7/17/14

# Horizontal Dimensional Data

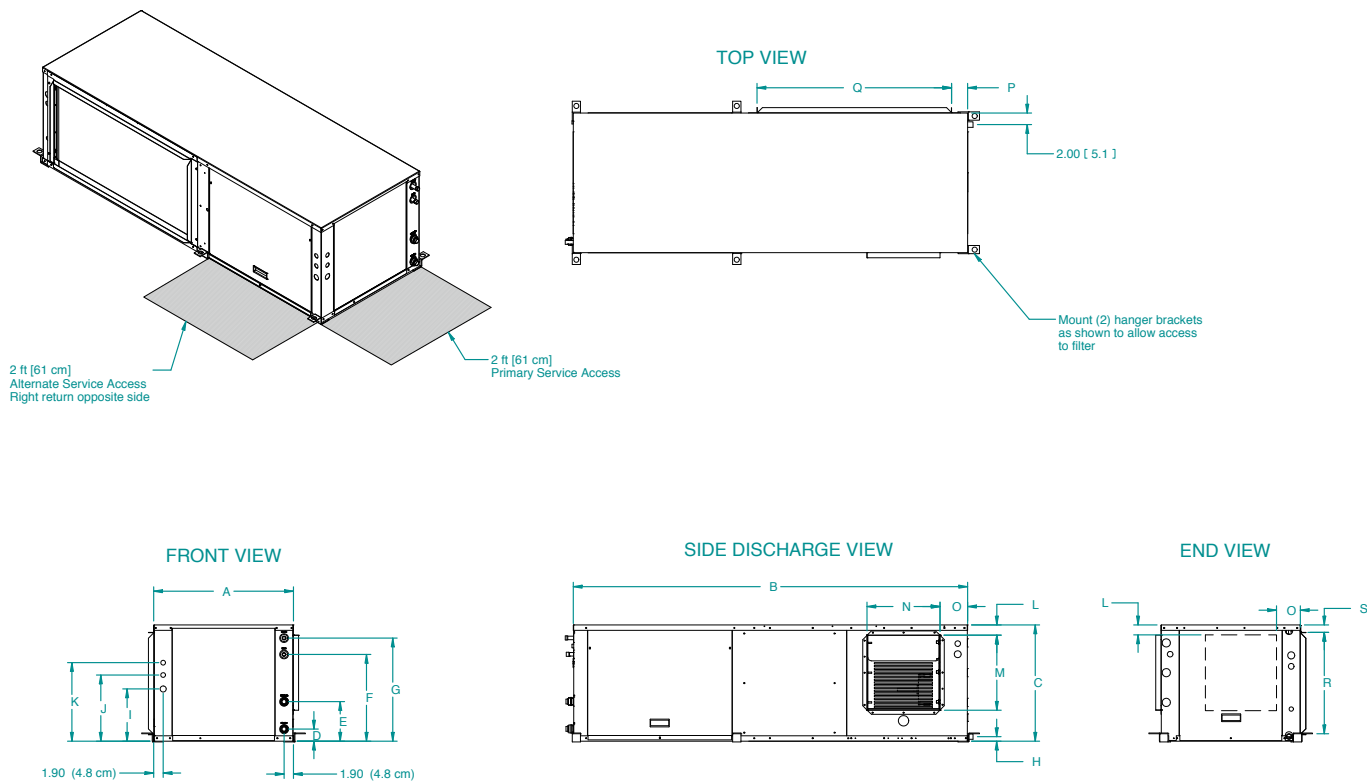

Horizontal Model	Overall Cabinet			Water Connections								Electrical Connections			Discharge Connection Duct Flange Installed				Return Connection Return Duct Flanges			
	A	B	C	D	E	F	G	H	Loop Water FPT	HWG Sweat (I.D.)	I	J	K	L*	M	N	O*	P	Q	R	S	
	Width	Depth	Height	In	Out	HWG In	HWG Out	Condensate			3/4" cond	1/2" cond	1/2" cond									Power Supply
	in.	cm.	in.	cm.	in.	cm.	in.	cm.	in.	cm.	in.	cm.	in.	cm.	in.	cm.	in.	cm.	in.	cm.	in.	cm.
024	in.	22.5	53.0	19.3	2.3	5.3	13.8	16.8	0.8	1"	1/2"	8.9	11.5	13.7	1.7	10.5	9.5	8.2	2.2	21.8	16.5	1.5
	cm.	57.2	134.6	49.0	5.8	13.5	35.1	42.7	2.0	Swivel	female	22.6	29.2	34.8	4.3	26.7	24.1	20.8	5.6	55.4	41.9	3.8
036	in.	22.5	63.0	19.3	2.3	7.3	13.5	16.5	0.8	1"	1/2"	9.5	12.1	14.3	2.3	10.5	9.5	5.7	2.8	30.5	16.7	1.3
	cm.	57.2	160.0	49.0	5.8	18.5	34.3	41.9	2.0	Swivel	female	24.1	30.7	36.3	5.8	26.7	24.1	14.5	7.1	77.5	42.4	3.3
048-060	in.	25.6	72.0	21.3	2.3	7.3	15.9	18.9	0.8	1"	1/2"	9.5	12.1	14.3	1.9	13.6	13.2	5.0	2.9	35.5	18.6	1.3
	cm.	65.0	182.9	54.1	5.8	18.5	40.4	48.0	2.0	Swivel	female	24.1	30.7	36.3	4.8	34.5	33.5	12.7	7.4	90.2	47.2	3.3
072	in.	25.6	77.0	21.3	2.3	7.3	15.9	18.9	0.8	1"	1/2"	9.5	12.1	14.3	1.9	13.6	13.2	5.0	2.8	40.4	18.7	1.5
	cm.	65.0	195.6	54.1	5.8	18.5	40.4	48.0	2.0	Swivel	female	24.1	30.7	36.3	4.8	34.5	33.5	12.7	7.1	102.6	47.5	3.8

\* Dimensions shown are for left return side discharge other configurations shown in tables below

7/17/14

Condensate is 3/4" PVC female glue socket and is switchable from side to front

Unit shipped with 1" [25.4mm] return duct flanges suitable for duct connection.

Discharge flange is field installed and extends 1" [25.4mm] from cabinet

Water connections extend 1.2" [30.5mm] beyond front of cabinet.

The optional 1" filter rack (not shown) has the same return opening connection size as the duct flanges shown in the drawing. The filter rack extends 2.25"(57.1 mm) from the unit.

The optional 1" filter rack is suitable for duct connection.

The optional filter rails (not shown) extend 1.25" (31.75 mm) from cabinet.

The 024 model is not field convertible changing from end to side discharge. It requires an additional discharge panel (not supplied).

024 Model		L	O
Right Return End Discharge	in	2.2	5.7
	cm	5.6	14.5
Right Return Side Discharge	in	6.9	8.3
	cm	17.5	21.1
Left Return End Discharge	in	6.5	7.3
	cm	16.5	18.5

036 Model		L	O
Right Return End Discharge	in	6.5	6.6
	cm	16.5	16.8
Right Return Side Discharge	in	2.3	5.7
	cm	5.8	14.5
Left Return End Discharge	in	6.5	6.6
	cm	16.5	16.8

048-060 Models		L	O
Right Return End Discharge	in	1.9	5.0
	cm	4.8	12.7
Right Return Side Discharge	in	5.7	5.0
	cm	14.5	12.7
Left Return End Discharge	in	5.7	4.9
	cm	14.5	12.4

072 Model		L	O
Right Return End Discharge	in	1.9	5.0
	cm	4.8	12.7
Right Return Side Discharge	in	5.7	5.0
	cm	14.5	12.7
Left Return End Discharge	in	5.7	5.0
	cm	14.5	12.7

## Physical Data

Model		Dual Capacity				
		024	036	048	060	072
Compressor (1 each)		Copeland Ultra Tech, Dual Capacity Scroll				
Factory Charge R410a, oz [kg]	Vertical	39 [1.05]	52 [1.47]	68 [1.93]	76 [2.15]	88 [2.49]
Factory Charge R410a, oz [kg]	Horizontal	38 [1.08]	52 [1.47]	68 [1.93]	72 [2.04]	85 [2.41]
<b>ECM Blower Motor &amp; Blower</b>						
Blower Motor Type/Speeds	ECM	5 Speed ECM				
Blower Motor- hp [W]	ECM	1/2 [373]	1/2 [373]	1 [746]	1 [746]	1 [746]
Blower Wheel Size (Dia x W), in. [mm]	ECM	9 x 7 [229 x 178]	9 x 7 [229 x 178]	11 x 10 [279 x 254]	11 x 10 [279 x 254]	11 x 10 [279 x 254]
<b>Coax and Water Piping</b>						
Water Connections Size - Swivel - in [mm]		1" [25.4]	1" [25.4]	1" [25.4]	1" [25.4]	1" [25.4]
HWG Connection Size - Female Sweat I.D. - in [mm]		1/2" [12.7]	1/2" [12.7]	1/2" [12.7]	1/2" [12.7]	1/2" [12.7]
Coax & Piping Water Volume - gal [l]		.35 [1.3]	.7 [2.6]	.7 [2.6]	1.3 [4.9]	1.6 [6.1]
<b>Vertical</b>						
Air Coil Dimensions (H x W), in. [mm]		19 x 20 [483 x 508]	24 x 20 [610 x 508]	28 x 25 [711 x 635]	28 x 25 [711 x 635]	32 x 25 [813 x 635]
Air Coil Total Face Area, ft2 [m2]		2.6 [0.245]	3.3 [0.310]	4.9 [0.452]	4.9 [0.452]	5.6 [0.516]
Air Coil Tube Size, in [mm]		3/8 [9.5]	3/8 [9.5]	3/8 [9.5]	3/8 [9.5]	3/8 [9.5]
Air Coil Number of rows		3	3	3	3	3
Optional Filter - 1" [25mm] Pleated MERV8 Throwaway, in [mm]		20 x 24 [508 x 610]	24 x 24 [610 x 610]	28 x 30 [711 x 762]	28 x 30 [711 x 762]	30 x 32 [762 x 813]
Weight - Operating, lb [kg]		198 [90]	221 [100]	303 [137]	329 [149]	350 [159]
Weight - Packaged, lb [kg]		218 [99]	241 [109]	323 [147]	349 [158]	370 [168]
<b>Horizontal</b>						
Air Coil Dimensions (H x W), in. [mm]		18 x 21 [457 x 533]	18 x 27 [457 x 686]	20 x 35 [508 x 889]	20 x 35 [508 x 889]	20 x 40 [508 x 1016]
Air Coil Total Face Area, ft2 [m2]		2.6 [2.44]	3.4 [0.314]	4.9 [0.452]	4.9 [0.452]	5.6 [0.516]
Air Coil Tube Size, in [mm]		3/8 [9.5]	3/8 [9.5]	3/8 [9.5]	3/8 [9.5]	3/8 [9.5]
Air Coil Number of rows		3	3	3	3	3
Optional Filter - 1" [25mm] Pleated MERV8 Throwaway, in [mm]		1 - 18 x 24 [457 x 610]	1 - 18 x 32 [457 x 813]	1 - 20 x 37 [508 x 940]	1 - 20 x 37 [508 x 940]	1 - 20 x 20 [508 x 508] 1 - 20 x 22 [508 x 559]
Weight - Operating, lb [kg]		228 [103]	250 [113]	325 [147]	358 [162]	369 [167]
Weight - Packaged, lb [kg]		248 [112]	270 [122]	345 [156]	378 [171]	389 [176]

12/14/2016

## The Aurora™ Control System

### Aurora 'Base' Control









The Aurora 'Base' Control (ABC) System is a complete residential and commercial comfort system that brings all aspects of the HVAC system into one cohesive module network. The ABC features microprocessor control and HP, LP, condensate and freeze detection, over/under voltage faults, along with

communicating thermostat capability for complete fault detection text at the thermostat. Aurora uses the Modbus communication protocol to communicate between modules. Each module contains the logic to control all features that are connected to the module. The Aurora 'Base' Control (ABC) has two Modbus channels. The first channel is configured as a master for connecting to devices such as a communicating thermostat or other slave devices. The second channel is configured as a slave for connecting the Aurora Interface Diagnostics Tool (AID Tool).

## The Aurora™ Control System cont..

Aurora Control Features	Description	Aurora 'Base'
Microprocessor Compressor Control	Microprocessor control of compressor for timings with FP1, HP, LP, Condensate, assignable Acc relay	•
Base Hot Water Generator Operation	Compressor Contactor powers Hot Water Generator Pump with inline circuit breaker and thermostat limit.	•
Base Loop Pump Control	Compressor Contactor powers Loop Pump with inline circuit breaker and no loop pump linking capability.	•
Load Shed/Utility Input	Allows simple input to externally enable of occupied/unoccupied mode for basic utility time of use programs.	•

Service Device	Description	Aurora 'Base'
 <p><b>Aurora Interface and Diagnostics (AID) Tool</b></p>	<p>Allows setup, monitoring and troubleshooting of any Aurora Control.</p> <p><b>NOTE:</b> Although the ABC has basic compatibility with all Aurora, new product features may not be available on older AID Tools.</p>	<p>For Service (Ver. 2.xx or greater)</p>

Add On Thermostats and Zoning	Description	Aurora 'Base'
 <p><b>TP32U03/04 - MonoChrome Traditional Y1, Y2 Thermostat</b></p>	<p>Elite Stat with full English fault codes and alerts, traditional Y1, Y2 thermostat, 8 wire installation</p>	<p>Optional</p>
 <p><b>TP32S01/02 - Traditional Y1, Y2 Thermostat</b></p>	<p>Traditional Y1, Y2 thermostat, 8 wire installation</p>	<p>Optional</p>
 <p><b>TPCM32U03A*/04A* - MonoChrome Communicating Thermostat</b></p>	<p>Elite Stat with full English fault codes and alerts, communicating thermostat, 4 wire installation</p>	<p>Optional</p>
 <p><b>TPCC32U01 - Color Touchscreen Communicating Thermostat</b></p>	<p>4.3 in. color touchscreen communicating thermostat with full English fault codes and alerts, 4 wire installation</p>	<p>Optional</p>
 <p><b>IntelliZone2® • 24V Zoning</b></p>	<p>IntelliZone2® • 24V is a communicating zoning system that includes color main thermostat and up to 4 zones (with dual capacity). There are 3 thermostat options (MasterStat, SensorStat, ZoneStat). Includes daughter board to translate communication to 24VAC for heat pump</p>	<p>Optional</p>

## The Aurora Control System cont.

### Aurora 'Base' Control

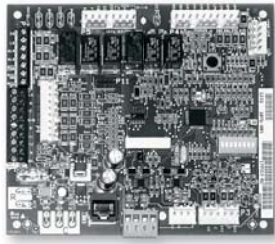

**NOTE:** Refer to the Aurora Base Control Application and Troubleshooting Guide and the Instruction Guide: Aurora Interface and Diagnostics (AID) Tool for additional information.

### Control Features

Software ABC Standard Version 3.0

#### 5-Speed ECM Blower Motor

A 5-Speed ECM blower motor will be driven directly using the thermostat connections. Any of the G, Y1, or Y2/W signals can drive any of the 5 available pre-programmed blower speeds on the motor.

### Other Control Features

- Random start at power up
- Anti-short cycle protection
- High and low pressure cutouts
- Loss of charge
- Water coil freeze detection
- Over/under voltage protection
- Condensate overflow sensor
- Load shed
- Emergency shutdown
- Diagnostic LED
- Test mode push button switch
- Two auxiliary electric heat outputs
- Alarm output
- Accessory output with N.O. and N.C.
- Modbus communication (master)
- Modbus communication (slave)

### Field Selectable Options via Hardware

**DIP Switch (SW1)** – Test/Configuration Button (See SW1 Operation Table)

#### Test Mode

The control is placed in the test mode by holding the push button switch SW1 for 2 - 5 seconds. In test mode most of the control timings will be shortened by a factor of sixteen (16). LED3 (green) will flash at 1 second on and 1 second off. Additionally, when entering test mode LED1 (red) will flash the last lockout one time. Test mode will automatically time out after 30 minutes.

Test mode can be exited by pressing and holding the SW1 button for 2 to 5 seconds or by cycling the power. **NOTE:** Test mode will automatically be exited after 30 minutes.

### Reset Configuration Mode

The control is placed in reset configuration mode by holding the push button switch SW1 for 50 to 60 seconds. This will reset all configuration settings and the EEPROM back to the factory default settings. LED3 (green) will turn off when entering reset configuration mode. Once LED3 (green) turns off, release SW1 and the control will reset.

### DIP Switch (SW2)

- SW2-1** FP1 Selection – Low water coil temperature limit setting for freeze detection. On = 30°F; Off = 15°F.
- SW2-2** Not Used
- SW2-3** RV – O/B - thermostat type. Heat pump thermostats with “O” output in cooling or “B” output in Heating can be selected. On = O; Off = B.
- SW2-4 and 2-5** Access Relay Operation (P2)

Access Relay Operation	SW2-4	SW2-5
Cycle with Blower	ON	ON
Cycle with Compressor	OFF	OFF
Water Valve Slow Opening	ON	OFF
Cycle with Comm. T-stat Hum Cmd	OFF	ON

Cycle with Blower - The accessory relay will cycle with the blower output.

Cycle with Compressor - The accessory relay will cycle with the compressor output.

Water Valve Slow Opening - The accessory relay will cycle and delay both the blower and compressor output for 90 seconds.

- SW2-6** CC Operation – selection of single or dual capacity compressor. On = Single Stage; Off = Dual Capacity
- SW2-7** Lockout and Alarm Outputs (P2) – selection of a continuous or pulsed output for both the LO and ALM Outputs. On = Continuous; Off = Pulsed
- SW2-8** Future Use

### Alarm Jumper Clip Selection

From the factory, ALM is connected to 24 VAC via JW2. By cutting JW2, ALM becomes a dry contact connected to ALG.



## The Aurora 'Base' Control System cont.

### Field Selectable Options via Software

(Selectable via the Aurora AID Tool)

#### Safety Features

The following safety features are provided to protect the compressor, heat exchangers, wiring and other components from damage caused by operation outside of design conditions.

**Fuse** – a 3 amp automotive type plug-in fuse provides protection against short circuit or overload conditions.

**Anti-Short Cycle Protection** – 4 minute anti-short cycle protection for the compressor.

**Random Start** – 5 to 80 second random start upon power up.

**Fault Retry** – in the fault condition, the control will stage off the outputs and then “try again” to satisfy the thermostat Y input call. Once the thermostat input calls are satisfied, the control will continue on as if no fault occurred. If 3 consecutive faults occur without satisfying the thermostat Y input call, then the control will go to Lockout mode.

**Lockout** – when locked out, the blower will operate continuously. The Alarm output (ALM) and Lockout output (L) will be turned on. The fault type identification display LED1 (Red) shall flash the fault code. To reset lockout conditions with SW2-8 On, thermostat inputs “Y1”, “Y2”, and “W” must be removed for at least 3 seconds. To reset lockout conditions with SW2-8 Off, thermostat inputs “Y1”, “Y2”, “W”, and “DH” must be removed for at least 3 seconds. Lockout may also be reset by turning power off for at least 30 seconds or by enabling the emergency shutdown input for at least 3 seconds.

**Lockout With Emergency Heat** - if the control is locked out in the heating mode and W input is received, the control will operate in the emergency heat mode while the compressor is locked out. The first emergency heat output will be energized 10 seconds after the W input is received, and the blower will shift to high speed. If the control remains locked out, and the W input is present, additional stage of emergency heat will stage on after 2 minutes. When the W input is removed, all of the emergency heat outputs and blower will turn off.

**High Pressure** – fault is recognized when the Normally Closed High Pressure Switch, P4-9/10 opens, no matter how momentarily. The High Pressure Switch is electrically in series with the Compressor Contactor and serves as a hard-wired limit switch if an overpressure condition should occur.

**Low Pressure** - fault is recognized when the Normally Closed Low Pressure Switch, P4-7/8 is continuously open for 30 seconds. Closure of the LPS any time during the 30 second recognition time restarts the 30 second continuous open requirement. A continuously open LPS shall not be recognized during the 2 minute startup bypass time.

**Loss of Charge** – fault is recognized when the Normally Closed Low Pressure Switch, P4-7/8 is open prior to the compressor starting.

**Condensate Overflow** - fault is recognized when the impedance between this line and 24 VAC common or chassis ground drops below 100K ohms for 30 seconds continuously.

**Freeze Detection (Coax)** - set points shall be either 30°F or 15°F. When the thermistor temperature drops below the selected set point, the control shall begin counting down the 30 seconds delay. If the thermistor value rises above the selected set point, then the count should reset. The resistance value must remain below the selected set point for the entire length of the appropriate delay to be recognized as a fault. This fault will be ignored for the initial 2 minutes of the compressor run time.

**Over/Under Voltage Shutdown** - An over/under voltage condition exists when the control voltage is outside the range of 18 VAC to 30 VAC. If the over/under voltage shutdown lasts for 15 minutes, the lockout and alarm relay will be energized. Over/under voltage shutdown is self-resetting in that if the voltage comes back within range of 18 VAC to 30 VAC for at least 0.5 seconds, then normal operation is restored.

### Operation Description

**Power Up** - The unit will not operate until all the inputs and safety controls are checked for normal conditions. The unit has a 5 to 80 second random start delay at power up. Then the compressor has a 4 minute anti-short cycle delay after the random start delay.

**Standby** - In standby mode, Y1, Y2, W, DH, and G are not active. Input O may be active. The blower and compressor will be off.

#### Heating Operation

**Heating, 1st Stage (Y1)** - The blower is started on “Y1” speed immediately and the compressor is energized 10 seconds after the Y1 input is received.

**Heating, 2nd Stage (Y1, Y2)** - The compressor will be staged to full capacity 20 seconds after Y2 input is received. The 5 speed ECM blower will shift to Y2 speed immediately.

**Heating, 3rd Stage (Y1, Y2, W)** - The first stage of electric heat is energized 10 seconds after the W command is received. Blower will increase to “W” speed immediately. If the demand continues the second stage of electric heat will be energized after 5 minutes.



## The Aurora ‘Base’ Control System cont.

**Emergency Heat (W)** - The blower will be started on “W” speed, 10 seconds later the first stage of electric heat will be turned on. If the emergency heat demand is not satisfied after 2 minutes the second electric heat stage will be energized.

**Blower (G)** - The blower will start immediately upon receiving a thermostat G command. If there are no other commands from the thermostat the ECM will run on “G” speed until the G command is removed. Regardless of blower input (G) from the thermostat, the blower will remain on for 30 seconds at the end of each heating cycle.

### Cooling Operation

In all cooling operations, the reversing valve directly tracks the O input. Thus, anytime the O input is present, the reversing valve will be energized.

**Cooling, 1st Stage (Y1, O)** - The blower is started on “Y1” speed immediately and the compressor is energized 10 seconds after the Y1 input is received.

**Cooling, 2nd Stage (Y1, Y2, O)** - The compressor will be staged to full capacity 20 seconds after Y2 input is received. The 5 speed ECM blower will shift to Y2 speed immediately.

**Emergency Shutdown** - Four (4) seconds after a valid ES input, P2-7 is present, all control outputs will be turned off and remain off until the emergency shutdown input is no longer present. The first time that the compressor is started after the control exits the emergency shutdown mode, there will be an anti-short cycle delay followed by a random start delay. Input must be tied to common to activate.

**Continuous Blower Operation** - The blower output will be energized any time the control has a G input present, unless the control has an emergency shutdown input present. The blower output will be turned off when G input is removed.

**Load Shed** - The LS input disables all outputs with the exception of the blower output. When the LS input has been cleared, the anti-short cycle timer and random start timer will be initiated. Input must be tied to common to activate.

## Aurora ‘Base’ Control LED Displays

These three LEDs display the status, configuration, and fault codes for the control. These can also be read in plain English via the Aurora AID Tool.

### Status LED (LED3, Green)

Description of Operation	Fault LED, Green
Normal Mode	ON
Control is Non-functional	OFF
Test Mode	Slow Flash
Lockout Active	Fast Flash
Dehumidification Mode	Flash Code 2
(Future Use)	Flash Code 3
(Future Use)	Flash Code 4
Load Shed	Flash Code 5
Emergency Shutdown	Flash Code 6
Smart Grid	Flash Code 7

### Configuration LED (LED2, Yellow)

Description of Operation	Configuration LED, Yellow
No Software Overwritten	Flashing ECM Setting
DIP Switch was Overwritten	Slow Flash
ECM Configuration Mode	Fast Flash

### Fault LED (LED1, Red)

Red Fault LED		LED Flash Code*	Lockout	Reset/Remove
ABC Basic Faults	Normal - No Faults	OFF	–	
	Fault - Input	1	No	Auto
	Fault - High Pressure	2	Yes	Hard or Soft
	Fault - Low Pressure	3	Yes	Hard or Soft
	Fault - Freeze Detection FP2	4	Yes	Hard or Soft
	Fault - Freeze Detection FP1	5	Yes	Hard or Soft
	Fault - Condensate Overflow	7	Yes	Hard or Soft
	Fault - Over/Under Voltage	8	No	Auto
	Fault - FP1 Sensor Error	11	Yes	Hard or Soft
	Fault - CritComErr	19	NO	Auto

**NOTE:** All codes >11 use long flash for tens digit and short flash for the ones digit. 20, 30, 40, 50, etc. are skipped.

## The Aurora 'Base' Control System cont.

### Aurora Interface and Diagnostics (AID) Tool



The Aurora Interface and Diagnostics (AID) Tool is a device that is a member of the Aurora network. The AID Tool is used to troubleshoot equipment which uses the Aurora control via Modbus RTU communication. The AID Tool provides diagnostics, fault management and system configuration capabilities to the Aurora family of controls. An AID Tool is recommended, although not required. The AID Tool simply plugs into the exterior of the cabinet in the AID Tool port

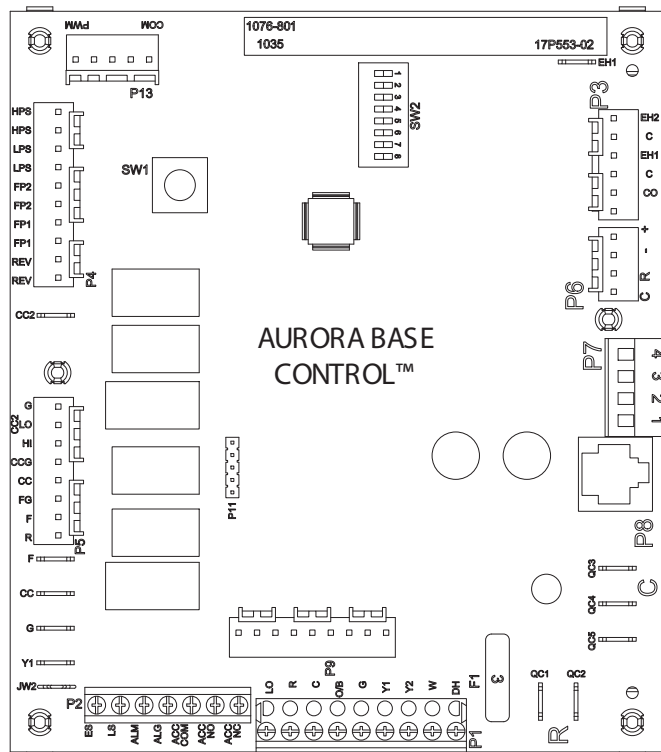

## Reference Calculations

Heating Calculations:	Cooling Calculations:
$LWT = EWT - \frac{HE}{\text{gpm} \times 500}$	$LWT = EWT + \frac{HR}{\text{gpm} \times 500}$
$LAT = EAT + \frac{HC}{\text{cfm} \times 1.08}$	$LAT (DB) = EAT (DB) - \frac{SC}{\text{cfm} \times 1.08}$
$TH = HC + HW$	$LC = TC - SC$
	$S/T = \frac{SC}{TC}$

## Legend

### Abbreviations and Definitions

cfm	= airflow, cubic feet/minute	COP	= Coefficient of Performance = Btu output/Btu input
EWT	= entering water temperature, Fahrenheit	LWT	= leaving water temperature, °F
gpm	= water flow in gallons/minute	LAT	= leaving air temperature, °F
WPD	= water pressure drop, psi and feet of water	TH	= total heating capacity, MBtu/h
EAT	= entering air temperature, Fahrenheit (dry bulb/wet bulb)	LC	= latent cooling capacity, MBtu/h
HC	= air heating capacity, MBtu/h	S/T	= sensible to total cooling ratio
TC	= total cooling capacity, MBtu/h		
SC	= sensible cooling capacity, MBtu/h		
kW	= total power unit input, kilowatts		
HR	= total heat of rejection, MBtu/h		
HE	= total heat of extraction, MBtu/h		
HWC	= hot water generator capacity, MBtu/h		
EER	= Energy Efficient Ratio = Btu output/Watt input		

### Notes to Performance Data Tables

The following notes apply to all performance data tables:

- Performance ratings are based on 80°F DB/67°F WB EAT for cooling and 70°F DB EAT for heating.
- Three flow rates are shown for each unit. The lowest flow rate shown is used for geothermal open loop/well water systems with a minimum of 50°F EWT. The middle flow rate shown is the minimum geothermal closed loop flow rate. The highest flow rate shown is optimum for geothermal closed loop systems and the suggested flow rate for boiler/tower applications.
- The hot water generator numbers are based on a flow rate of 0.4 gpm/ton of rated capacity with an EWT of 90°F.
- Entering water temperatures below 40°F assumes 15% antifreeze solution.
- For non-standard EAT conditions, apply the appropriate Correction Factor tables.
- Interpolation between EWT, gpm, and cfm data is permissible, extrapolation is not.

# Wiring Schematics

## Aurora BASE with 5-Speed ECM

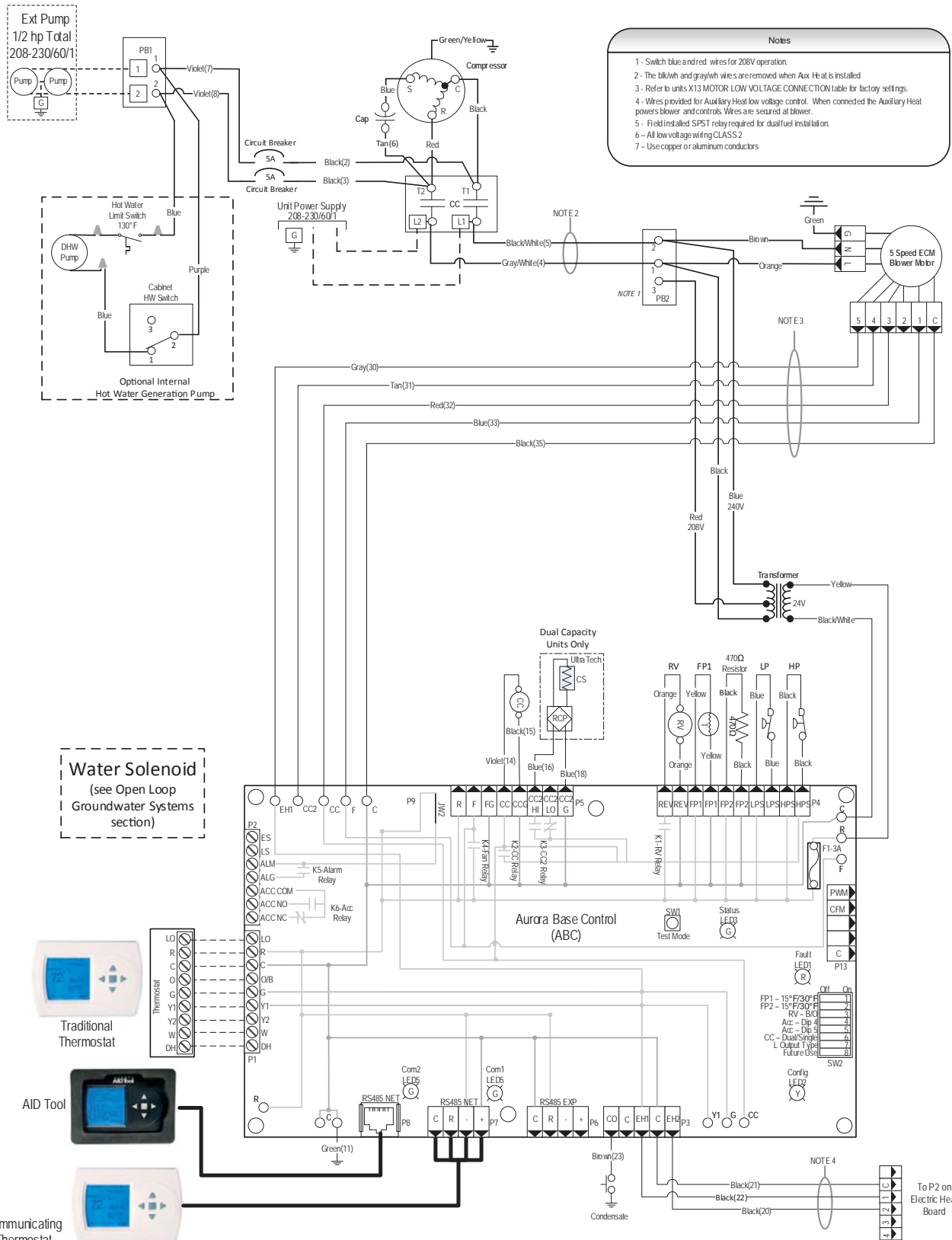

# Wiring Schematics cont.

## Aurora BASE with 5-Speed ECM cont.

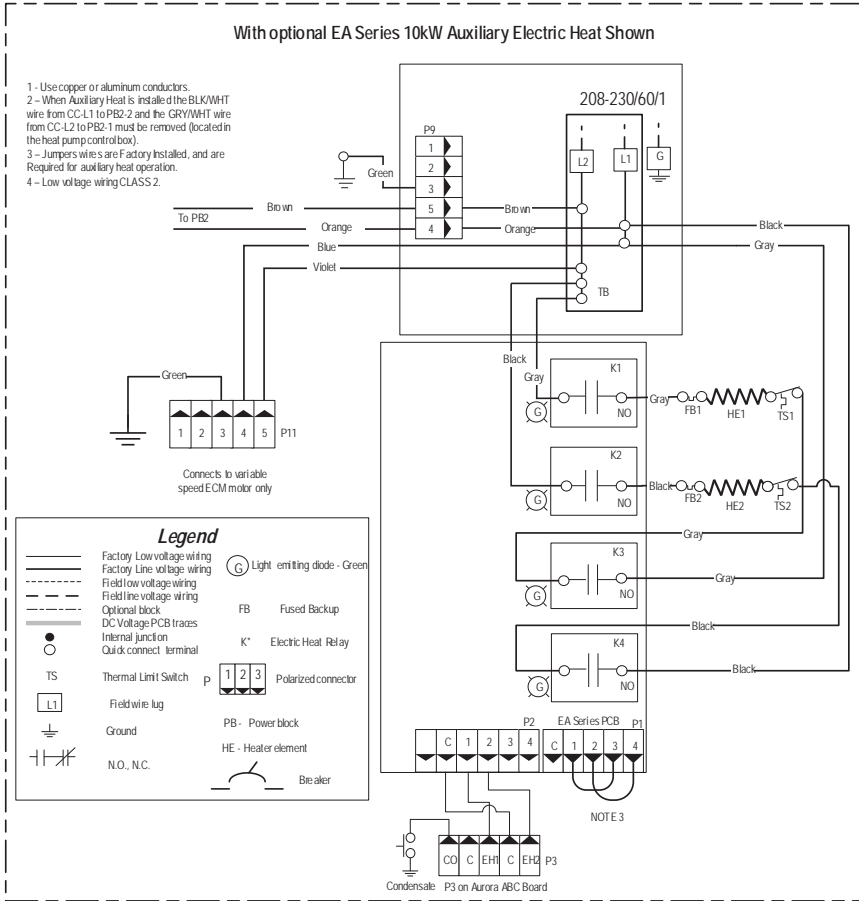

Aurora LED Flash Codes			
Slow Flash	1 second on and 1 second off		
Fast Flash	100 milliseconds on and 100 milliseconds off		
Flash Code	100 milliseconds on and 400 milliseconds off with a 2 second pause before repeating		
Random Start Delay (Alternating Colors)		Configuration LED (LED2, Yellow)	
Status LED (LED1, Green)	Fast Flash	No Software Override	OFF
Configuration LED (LED2, Yellow)	Fast Flash	DIP Switch Override	Slow Flash
Fault LED (LED3, Red)	Fast Flash		
Fault LED (LED1, Red)		Status LED (LED3, Green)	
Normal Mode	OFF	Normal Mode	ON
Input Fault Lockout	Flash Code 1	Control is Non-Functional	OFF
High Pressure Lockout	Flash Code 2	Test Mode	Slow Flash
Low Pressure Lockout	Flash Code 3	Lockout Active	Fast Flash
Future Use	Flash Code 4	Dehumidification Mode	Flash Code 2
Freeze Detection - FP1	Flash Code 5	Future Use	Flash Code 3
Reserved	Flash Code 6	Future Use	Flash Code 4
Condensate Overflow Lockout	Flash Code 7	Load Shed	Flash Code 5
Over/Under Voltage Shutdown	Flash Code 8	ESD	Flash Code 6
Future Use	Flash Code 9	Future Use	Flash Code 7
Future Use	Flash Code 10		
FP1 Sensor Error	Flash Code 11		

ABC SW2 Accessory Relay		
DESCRIPTION	SW2-4	SW2-5
Cycle with Blower	ON	ON
Cycle with Compressor	OFF	OFF
Water Valve Slow Opening	ON	OFF
Cycle with Comm. T-stat Hum Cmd	OFF	ON

Aurora Timing Events			
Event	Normal Mode	Test Mode	
Random Start Delay	5 to 80 seconds	1 second	
Compressor On Delay	5 seconds	< 1 second	
Compressor Minimum On Time	2 minutes	5 seconds	
Compressor Short Cycle Delay	4 minutes	15 seconds	
Blower Off Delay	30 seconds	2 seconds	
Fault Recognition Delay - High Pressure	Less than 1 second	Less than 1 second	
Start-Up Bypass - Low Pressure	2 minutes	30 seconds	
Fault Recognition Delay - Low Pressure	30 seconds	30 seconds	
Start-Up Bypass - Low Water Coil Limit	2 minutes	30 seconds	
Fault Recognition Delay - Low Water Coil Limit	30 seconds	30 seconds	
Fault Recognition Delay - Condensate Overflow	30 seconds	30 seconds	
Thermostat Call Recognition Time	2 seconds	2 seconds	
Comfort Alert Recognition Time	90 seconds	90 seconds	
Auxiliary Heat Staging Delay	5 minutes	20 seconds	
Emergency Heat Staging Delay	2 minutes	7.5 seconds	
Water Valve Slow Open Delay	90 seconds	90 seconds	

5 SPEED ECM MOTOR LOW VOLTAGE CONNECTIONS						
Model	TAP-1	TAP-2	TAP-3	TAP-4	TAP-5	
024	BLUE	RED		TAN	GRAY	
036	BLUE	RED		TAN	GRAY	
048	BLUE	RED		TAN	GRAY	
060	BLUE	RED		TAN	GRAY	
072	BLUE	RED		TAN	GRAY	

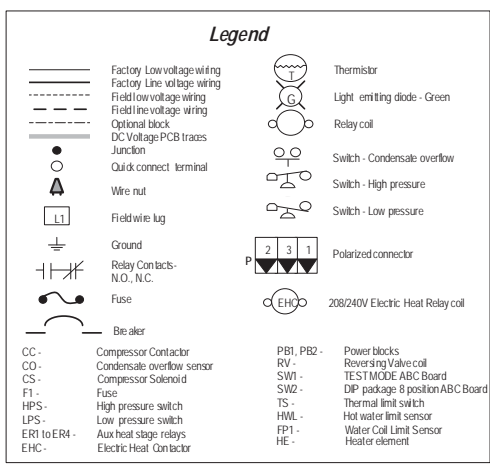
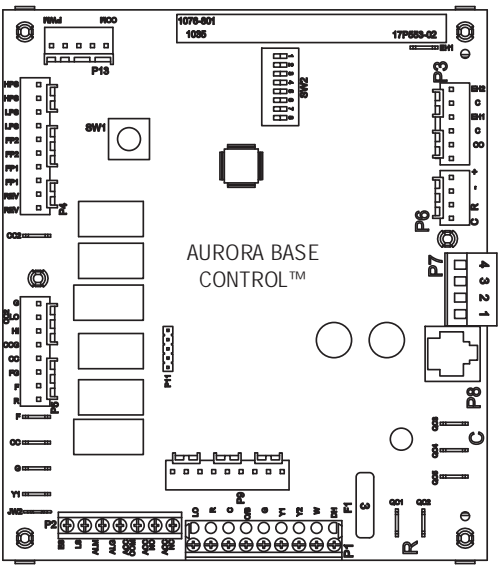

# Wiring Schematics cont.

## Aurora BASE with 5 Speed ECM and IntelliStart

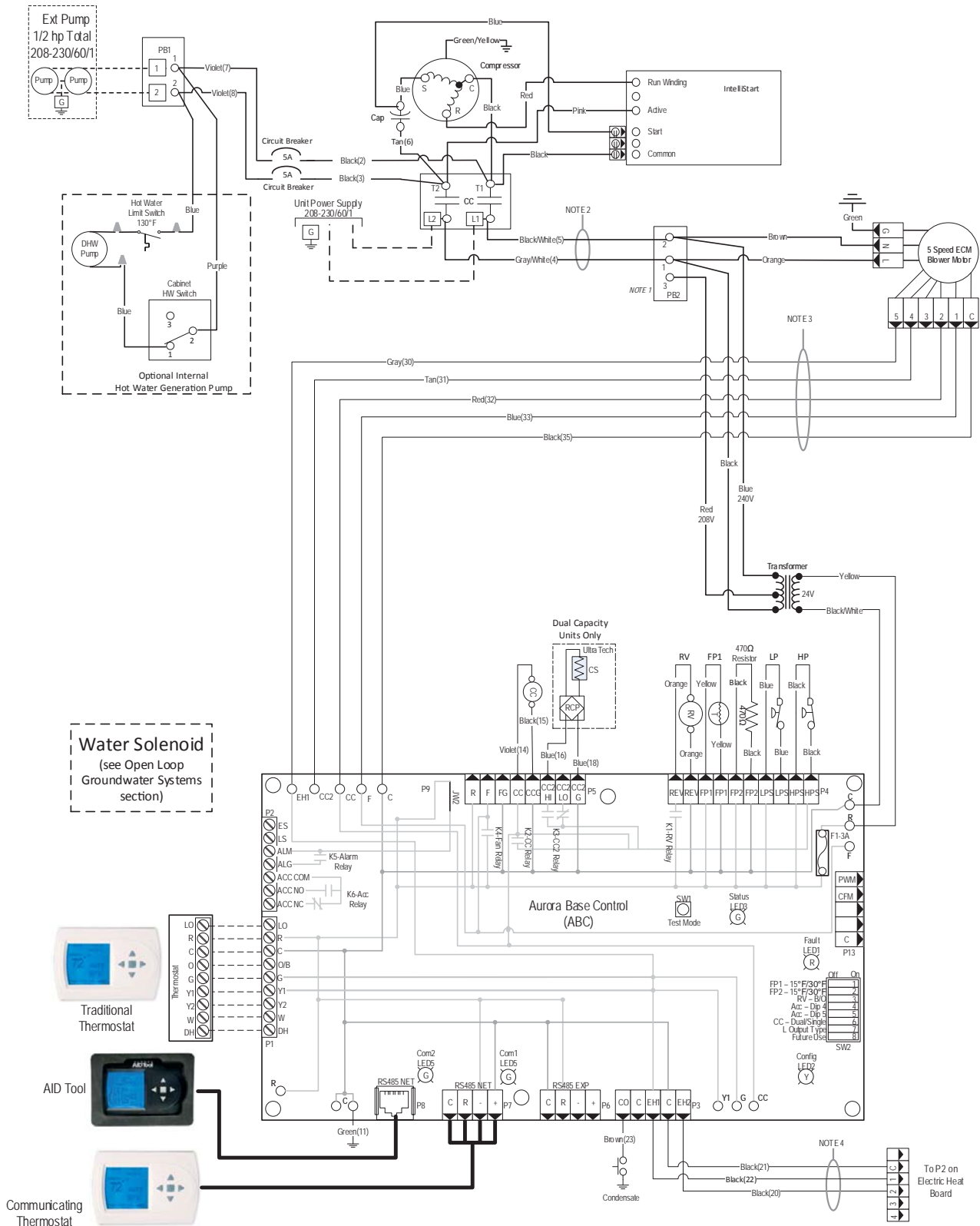

# Wiring Schematics cont.

## Aurora BASE with 5 Speed ECM and IntelliStart

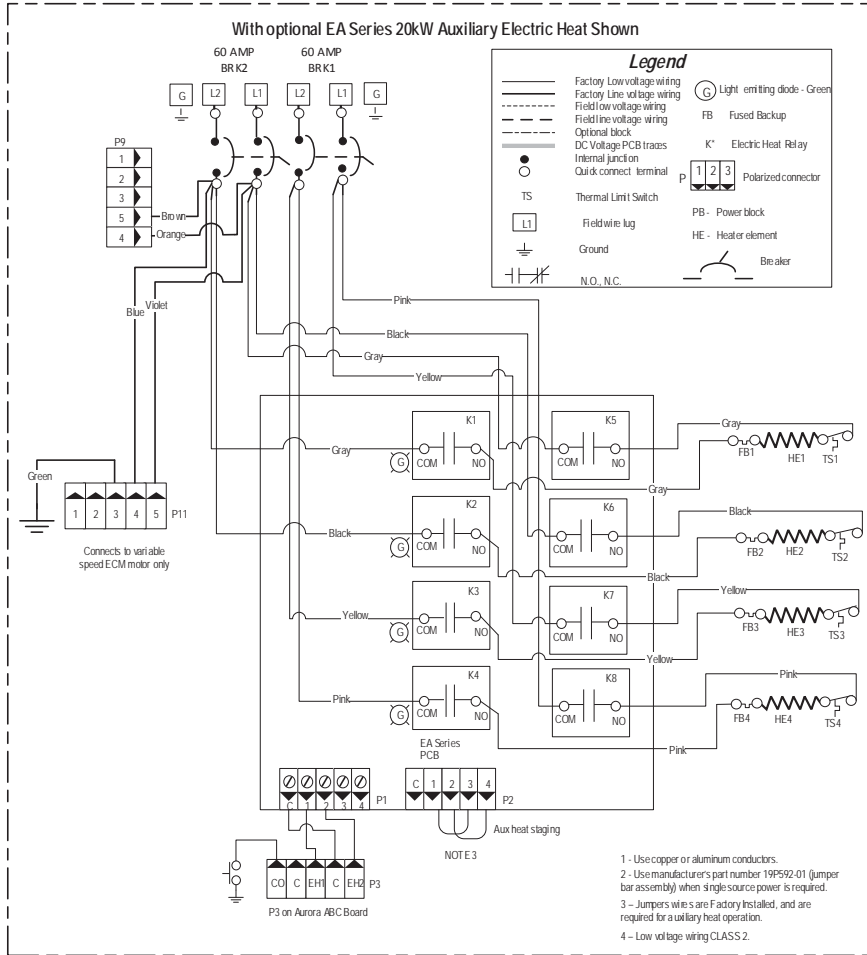

**Aurora LED Flash Codes**

Slow Flash	1 second on and 1 second off		
Fast Flash	100 milliseconds on and 100 milliseconds off		
Flash Code	100 milliseconds on and 400 milliseconds off with a 2 second pause before repeating		
Random Start Delay (Alternating Colors)	Configuration LED (LED2, Yellow)		
Status LED (LED1, Green)	Fast Flash	No Software Override	OFF
Configuration LED (LED2, Yellow)	Fast Flash	DIP Switch Override	Slow Flash
Fault LED (LED3, Red)	Fast Flash		
		Status LED (LED3, Green)	
Normal Mode	OFF	Normal Mode	ON
Input Fault Lockout	Flash Code 1	Control is Non-Functional	OFF
High Pressure Lockout	Flash Code 2	Test Mode	Slow Flash
Low Pressure Lockout	Flash Code 3	Lockout Active	Fast Flash
Future Use	Flash Code 4	Dehumidification Mode	Flash Code 2
Freeze Detect on - FP1	Flash Code 5	Future Use	Flash Code 3
Reversal	Flash Code 6	Future Use	Flash Code 4
Condensate Overflow Lockout	Flash Code 7	Lead Shed	Flash Code 5
Over/Under Voltage Shutdown	Flash Code 8	ESD	Flash Code 6
Future Use	Flash Code 9	Future Use	Flash Code 7
Future Use	Flash Code 10		
FP1 Sensor Error	Flash Code 11		

**ABC SW2 Accessory Relay**

DESCRIPTION	SW2-4	SW2-5
Cycle with Blower	ON	ON
Cycle with Compressor	OFF	OFF
Water Valve Slow Opening	ON	OFF
Cycle with Comm. T-stat Hum Cmd	OFF	ON

**Aurora Timing Events**

Event	Normal Mode	Test Mode
Random Start Delay	5 to 80 seconds	1 second
Compressor On Delay	5 seconds	< 1 second
Compressor Minimum On Time	2 minutes	5 seconds
Compressor Short Cycle Delay	4 minutes	15 seconds
Blower Off Delay	30 seconds	2 seconds
Fault Recogn Non Delay - High Pressure	Less than 1 second	Less than 1 second
Start-Up Bypass - Low Pressure	2 minutes	30 seconds
Fault Recogn Non Delay - Low Pressure	30 seconds	30 seconds
Start-Up Bypass - Low Water Coil Limit	2 minutes	30 seconds
Fault Recogn Non Delay - Low Water Coil Limit	30 seconds	30 seconds
Fault Recogn Non Delay - Condensate Overflow	30 seconds	30 seconds
Thermostat Call Recognition Time	2 seconds	2 seconds
Comfort Alert Recognition Time	90 seconds	90 seconds
Auxiliary Heat Staging Delay	5 minutes	20 seconds
Emergency Heat Staging Delay	2 minutes	7.5 seconds
Water Valve Slow Open Delay	90 seconds	90 seconds

**5 SPEED ECM MOTOR LOW VOLTAGE CONNECTIONS**

Model	TAP-1	TAP-2	TAP-3	TAP-4	TAP-5
024	BLUE	RED		TAN	GRAY
036	BLUE	RED		TAN	GRAY
048	BLUE	RED		TAN	GRAY
060	BLUE	RED		TAN	GRAY
072	BLUE	RED		TAN	GRAY

- Notes**
- 1 - Switch blue and red wires for 208V operation.
  - 2 - The blue and gray wires are removed when Aux Heat is installed.
  - 3 - Refer to units X13 MOTOR LOW VOLTAGE CONNECTION TABLE for factory settings.
  - 4 - Wires provided for Auxiliary Heat low voltage control. When connected the Auxiliary Heat powers blower and controls. Wires are secured at blower.
  - 5 - Field installed SPST relay required for dual field installation.
  - 6 - All low voltage wiring CLASS 2.
  - 7 - Use copper or aluminum conductors.

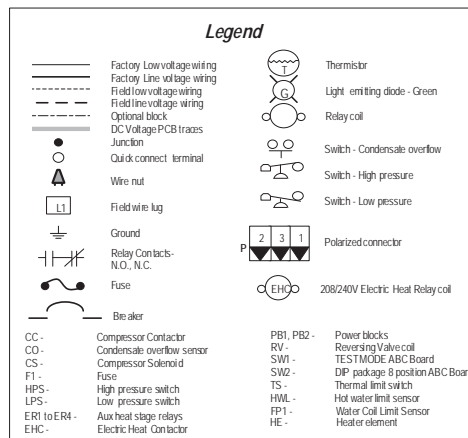
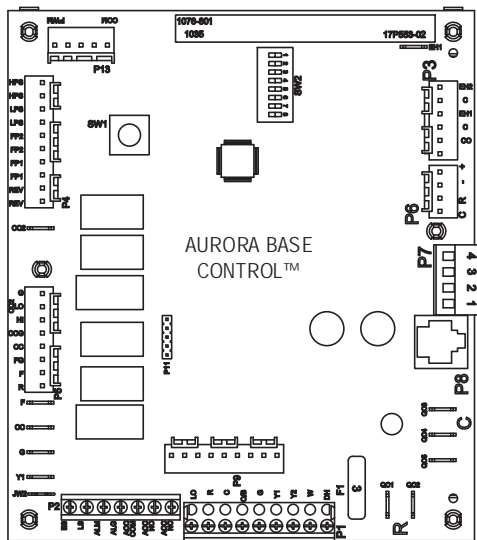

## Unit Startup

### Before Powering Unit, Check the Following:

**NOTE:** Remove and discard the compressor hold down shipping bolt located at the front of the compressor mounting bracket.

- **Black/white and gray/white wires in unit control box have been removed if auxiliary heat has been installed.**
- **Dip switches are set correctly.**
- **High voltage is correct and matches nameplate.**
- Fuses, breakers and wire size correct.
- Low voltage wiring complete.
- Piping completed and water system cleaned and flushed.
- Air is purged from closed loop system.
- Isolation valves are open, water control valves or loop pumps wired.
- Condensate line open and correctly pitched.
- Transformer switched to 208V if applicable.
- Hot water generator pump switch is "OFF" unless piping is completed and air has been purged.
- Blower rotates freely.
- Blower speed is correct.
- Air filter/cleaner is clean and in position.
- Service/access panels are in place.
- Return air temperature is between 50-80°F heating and 60-95°F cooling.
- Check air coil cleanliness to ensure optimum performance. Clean as needed according to maintenance guidelines. To obtain maximum performance the air coil should be cleaned before startup. A 10% solution of dishwasher detergent and water is recommended for both sides of coil, a thorough water rinse should follow.

## Powering The Controls

### Initial Configuration of the Unit

Before operating the unit, apply power and complete the following Aurora Startup procedure for the controls configuration. An AID Tool is not necessary but is recommended for setup, configuration and troubleshooting.

### Configure Aurora Screen

If using communicating thermostat - Confirm communicating thermostat is added and communicating. Set thermostat mode to off.

### Startup Steps

**NOTE:** Complete the Equipment Start-Up/Commissioning Check Sheet during this procedure. Refer to thermostat operating instructions and complete the startup procedure. Verify that the compressor shipping bolt has been removed.

1. Initiate a control signal to energize the blower motor.
2. Initiate a control signal to place the unit in the cooling mode. Cooling setpoint must be set below room temperature.
3. First stage cooling will energize after a time delay.
4. Be sure that the compressor and water control valve or loop pump(s) are activated.
5. Verify that the water flow rate is correct by measuring the pressure drop through the heat exchanger using the P/T plugs and comparing to unit performance data in catalog.
6. Check the temperature of both the supply and discharge water (see the Unit Operating Parameters tables).
7. Check for an air temperature drop of 15°F to 25°F across the air coil, depending on the fan speed and entering water temperature.
8. Decrease the cooling set point several degrees and verify high-speed blower operation.
9. Adjust the cooling setpoint above the room temperature and verify that the compressor and water valve or loop pumps deactivate.
10. Initiate a control signal to place the unit in the heating mode. Heating set point must be set above room temperature.
11. First stage heating will energize after a time delay.
12. Check the temperature of both the supply and discharge water (see the Unit Operating Parameters tables).
13. Check for an air temperature rise of 12°F to 35°F across the air coil, depending on the fan speed and entering water temperature.
14. If auxiliary electric heaters are installed, increase the heating setpoint until the electric heat banks are sequenced on. All stages of the auxiliary heater should be sequenced on when the thermostat is in the Emergency Heat mode. Check amperage of each element.
15. Adjust the heating setpoint below room temperature and verify that the compressor and water valve or loop pumps deactivate.
16. During all testing, check for excessive vibration, noise or water leaks. Correct or repair as required.
17. Set system to desired normal operating mode and set temperature to maintain desired comfort level.
18. Instruct the owner/operator in the proper operation of the thermostat and system maintenance.

**NOTE:** Be certain to fill out and forward all warranty registration papers.



## 024 Operating Parameters

### Dual Capacity Models

#### First Stage Operation

Entering Water Temp °F	Water Flow gpm/ton	Cooling -- No Hot Water Generation					
		Suction Pressure psig	Discharge Pressure psig	Superheat	Subcooling	Water Temp Rise °F	Air Temp Drop °F DB
30	1.5	108 - 123	135 - 145	10 - 15	5 - 12	14 - 19	17 - 25
	3.0	105 - 120	130 - 145	10 - 15	5 - 12	5 - 10	17 - 25
50	1.5	123 - 138	205 - 225	8 - 15	5 - 12	14 - 19	17 - 25
	3.0	120 - 135	180 - 200	8 - 15	5 - 12	5 - 10	17 - 25
70	1.5	135 - 145	275 - 290	6 - 12	5 - 12	14 - 19	17 - 25
	3.0	133 - 143	245 - 260	6 - 12	5 - 12	5 - 10	17 - 25
90	1.5	142 - 152	335 - 360	6 - 12	5 - 12	13 - 19	17 - 25
	3.0	140 - 150	320 - 345	6 - 12	5 - 12	5 - 10	17 - 25
110	1.5	152 - 164	425 - 455	6 - 12	5 - 12	13 - 19	17 - 25
	3.0	148 - 160	410 - 440	6 - 12	5 - 12	5 - 10	17 - 25

Entering Water Temp °F	Water Flow gpm/ton	Heating -- No Hot Water Generation					
		Suction Pressure psig	Discharge Pressure psig	Superheat	Subcooling	Water Temp Drop °F	Air Temp Rise °F DB
30	1.5	80 - 90	275 - 305	6 - 12	8 - 15	5 - 9	16 - 26
	3.0	84 - 94	280 - 310	6 - 12	8 - 15	2.5 - 6	18 - 28
50	1.5	100 - 115	290 - 320	7 - 13	8 - 15	5 - 9	20 - 30
	3.0	115 - 130	300 - 330	7 - 13	8 - 15	3 - 7	22 - 32
70	1.5	145 - 160	325 - 355	8 - 14	6 - 13	6 - 10	26 - 38
	3.0	150 - 165	330 - 360	8 - 14	6 - 13	4 - 8	28 - 40
90	1.5	185 - 200	340 - 380	12 - 18	6 - 13	7 - 11	28 - 40
	3.0	190 - 205	350 - 390	12 - 18	6 - 13	5 - 9	30 - 42
110	1.5						
	3.0						

Note: Cooling performance based on entering air temperatures of 80° F DB, 67° F WB.

Heating performance based on entering air temperature of 70° F DB.

#### Second Stage Operation

Entering Water Temp °F	Water Flow gpm/ton	Cooling -- No Hot Water Generation					
		Suction Pressure psig	Discharge Pressure psig	Superheat	Subcooling	Water Temp Rise °F	Air Temp Drop °F DB
30	1.5	108 - 125	155 - 180	18 - 30	5 - 12	15 - 21	17 - 25
	3.0	105 - 120	135 - 155	18 - 30	5 - 12	6 - 9	17 - 25
50	1.5	122 - 132	215 - 235	7 - 17	5 - 14	15 - 21	17 - 25
	3.0	120 - 130	190 - 210	7 - 17	5 - 14	6 - 9	17 - 25
70	1.5	133 - 143	280 - 310	6 - 15	5 - 12	14 - 20	17 - 25
	3.0	129 - 141	250 - 280	6 - 15	5 - 12	6 - 9	17 - 25
90	1.5	137 - 148	355 - 385	6 - 15	5 - 12	13 - 20	17 - 25
	3.0	135 - 146	325 - 355	6 - 15	5 - 12	6 - 9	17 - 25
110	1.5	145 - 155	435 - 465	6 - 15	5 - 12	13 - 20	17 - 25
	3.0	143 - 153	420 - 450	6 - 15	5 - 12	6 - 9	17 - 25

Entering Water Temp °F	Water Flow gpm/ton	Heating -- No Hot Water Generation					
		Suction Pressure psig	Discharge Pressure psig	Superheat	Subcooling	Water Temp Drop °F	Air Temp Rise °F DB
30	1.5	73 - 85	275 - 305	8 - 14	8 - 15	5 - 10	15 - 28
	3.0	77 - 90	285 - 315	8 - 14	8 - 15	3 - 7	17 - 30
50	1.5	100 - 115	295 - 335	9 - 15	9 - 17	7 - 11	20 - 32
	3.0	105 - 120	305 - 345	9 - 15	9 - 17	4 - 8	22 - 35
70	1.5	140 - 155	330 - 370	10 - 16	8 - 15	8 - 12	28 - 42
	3.0	145 - 160	335 - 375	10 - 16	8 - 15	5 - 9	30 - 45
90	1.5	175 - 195	350 - 390	10 - 16	8 - 15	8 - 13	30 - 46
	3.0	180 - 200	365 - 405	10 - 16	8 - 15	6 - 10	32 - 48
110	1.5						
	3.0						

Note: Cooling performance based on entering air temperatures of 80° F DB, 67° F WB.  
Heating performance based on entering air temperature of 70° F DB.

7/24/2014

## 036 Operating Parameters

### Dual Capacity Models First Stage Operation

Entering Water Temp °F	Water Flow gpm/ton	Cooling -- No Hot Water Generation					
		Suction Pressure psig	Discharge Pressure psig	Superheat	Subcooling	Water Temp Rise °F	Air Temp Drop °F DB
30	1.5	111 - 125	140 - 155	32 - 43	5 - 13	14 - 19	17 - 25
	3.0	108 - 122	135 - 148			5 - 10	17 - 25
50	1.5	138 - 153	210 - 240	12 - 18	5 - 12	15 - 20	17 - 25
	3.0	135 - 150	185 - 215			6 - 11	17 - 25
70	1.5	142 - 157	270 - 300	7 - 13	5 - 12	15 - 20	17 - 25
	3.0	140 - 155	250 - 280			6 - 11	17 - 25
90	1.5	142 - 163	350 - 380	6 - 12	5 - 12	13 - 19	17 - 25
	3.0	144 - 158	330 - 360			5 - 10	17 - 25
110	1.5	154 - 169	435 - 465	6 - 12	5 - 12	13 - 19	17 - 25
	3.0	153 - 167	420 - 450			5 - 10	17 - 25

Entering Water Temp °F	Water Flow gpm/ton	Heating -- No Hot Water Generation					
		Suction Pressure psig	Discharge Pressure psig	Superheat	Subcooling	Water Temp Drop °F	Air Temp Rise °F DB
30	1.5	77 - 87	275 - 305	6 - 12	8 - 15	5 - 9	15 - 25
	3.0	81 - 91	280 - 310			2.5 - 6	16 - 26
50	1.5	105 - 120	295 - 325	7 - 13	8 - 15	5 - 9	18 - 28
	3.0	110 - 125	305 - 335			3 - 7	20 - 30
70	1.5	140 - 155	330 - 360	8 - 14	8 - 15	6 - 10	24 - 36
	3.0	145 - 160	335 - 365			5 - 9	26 - 38
90	1.5	180 - 195	345 - 385	12 - 18	6 - 13	9 - 14	28 - 40
	3.0	185 - 200	355 - 395			7 - 11	30 - 42
110	1.5						
	3.0						

Note: Cooling performance based on entering air temperatures of 80° F DB, 67° F WB.  
Heating performance based on entering air temperature of 70° F DB.

### Second Stage Operation

Entering Water Temp °F	Water Flow gpm/ton	Cooling -- No Hot Water Generation					
		Suction Pressure psig	Discharge Pressure psig	Superheat	Subcooling	Water Temp Rise °F	Air Temp Drop °F DB
30	1.5	103 - 118	162 - 182	35 - 45	8 - 15	17 - 23	17 - 25
	3.0	100 - 115	142 - 162			8 - 11	17 - 25
50	1.5	124 - 138	220 - 250	20 - 26	8 - 15	18 - 24	17 - 25
	3.0	122 - 136	195 - 225			9 - 12	17 - 25
70	1.5	133 - 147	290 - 320	9 - 15	8 - 15	18 - 24	17 - 25
	3.0	130 - 145	260 - 290			9 - 12	17 - 25
90	1.5	137 - 148	370 - 400	6 - 12	8 - 15	18 - 24	17 - 25
	3.0	135 - 146	340 - 375			9 - 12	17 - 25
110	1.5	145 - 158	445 - 485	6 - 12	8 - 15	17 - 23	17 - 25
	3.0	143 - 156	430 - 470			8 - 11	17 - 25

Entering Water Temp °F	Water Flow gpm/ton	Heating -- No Hot Water Generation					
		Suction Pressure psig	Discharge Pressure psig	Superheat	Subcooling	Water Temp Drop °F	Air Temp Rise °F DB
30	1.5	68 - 82	290 - 320	6 - 12	13 - 19	5 - 10	15 - 28
	3.0	72 - 87	300 - 330			3 - 7	17 - 30
50	1.5	100 - 115	315 - 355	7 - 13	13 - 19	7 - 11	20 - 32
	3.0	105 - 120	325 - 365			4 - 8	22 - 35
70	1.5	131 - 146	340 - 380	8 - 14	12 - 18	9 - 14	25 - 37
	3.0	136 - 151	350 - 390			6 - 10	27 - 40
90	1.5	165 - 185	385 - 425	13 - 20	9 - 16	10 - 16	30 - 46
	3.0	170 - 190	395 - 435			8 - 13	32 - 48
110	1.5						
	3.0						

Note: Cooling performance based on entering air temperatures of 80° F DB, 67° F WB.  
Heating performance based on entering air temperature of 70° F DB.

7/24/2014

## 048 Operating Parameters

### Dual Capacity Models

#### First Stage Operation

Entering Water Temp °F	Water Flow gpm/ton	Cooling -- No Hot Water Generation					
		Suction Pressure psig	Discharge Pressure psig	Superheat	Subcooling	Water Temp Rise °F	Air Temp Drop °F DB
30	1.5	111 - 125	143 - 157	32 - 43	8 - 15	14 - 19	17 - 25
	3.0	108 - 122	138 - 150			5 - 10	17 - 25
50	1.5	138 - 153	210 - 240	15 - 21	5 - 12	15 - 20	17 - 25
	3.0	135 - 150	185 - 215			6 - 11	17 - 25
70	1.5	142 - 157	270 - 300	10 - 16	5 - 12	15 - 20	17 - 25
	3.0	140 - 155	250 - 280			6 - 11	17 - 25
90	1.5	143 - 165	350 - 380	6 - 12	5 - 12	13 - 19	17 - 25
	3.0	145 - 160	330 - 360			5 - 10	17 - 25
110	1.5	154 - 169	435 - 465	8 - 13	5 - 12	13 - 19	17 - 25
	3.0	153 - 167	420 - 450			5 - 10	17 - 25

Entering Water Temp °F	Water Flow gpm/ton	Heating -- No Hot Water Generation					
		Suction Pressure psig	Discharge Pressure psig	Superheat	Subcooling	Water Temp Drop °F	Air Temp Rise °F DB
30	1.5	77 - 87	275 - 305	6 - 12	3 - 8	5 - 9	15 - 25
	3.0	81 - 91	280 - 310			2.5 - 6	16 - 26
50	1.5	105 - 120	295 - 325	7 - 13	3 - 8	5 - 9	18 - 28
	3.0	110 - 125	305 - 335			3 - 7	20 - 30
70	1.5	140 - 155	330 - 360	8 - 14	3 - 8	6 - 10	24 - 36
	3.0	145 - 160	335 - 365			5 - 9	26 - 38
90	1.5	173 - 188	340 - 380	14 - 20	3 - 8	9 - 14	28 - 40
	3.0	178 - 193	350 - 390			6 - 10	30 - 42
110	1.5						
	3.0						

Note: Cooling performance based on entering air temperatures of 80° F DB, 67° F WB.

Heating performance based on entering air temperature of 70° F DB.

#### Second Stage Operation

Entering Water Temp °F	Water Flow gpm/ton	Cooling -- No Hot Water Generation					
		Suction Pressure psig	Discharge Pressure psig	Superheat	Subcooling	Water Temp Rise °F	Air Temp Drop °F DB
30	1.5	107 - 121	168 - 188	35 - 45	12 - 18	17 - 23	17 - 25
	3.0	104 - 118	148 - 168			8 - 11	17 - 25
50	1.5	127 - 141	225 - 255	20 - 26	8 - 15	18 - 24	17 - 25
	3.0	125 - 139	200 - 230			9 - 12	17 - 25
70	1.5	137 - 150	297 - 327	12 - 19	8 - 15	18 - 24	17 - 25
	3.0	134 - 148	267 - 297			9 - 12	17 - 25
90	1.5	142 - 156	370 - 400	10 - 16	8 - 15	18 - 24	17 - 25
	3.0	140 - 154	340 - 375			9 - 12	17 - 25
110	1.5	148 - 162	445 - 485	6 - 12	8 - 15	17 - 23	17 - 25
	3.0	146 - 160	430 - 470			8 - 11	17 - 25

Entering Water Temp °F	Water Flow gpm/ton	Heating -- No Hot Water Generation					
		Suction Pressure psig	Discharge Pressure psig	Superheat	Subcooling	Water Temp Drop °F	Air Temp Rise °F DB
30	1.5	68 - 82	280 - 310	6 - 12	6 - 12	5 - 10	15 - 25
	3.0	72 - 87	290 - 320			3 - 7	16 - 26
50	1.5	95 - 110	295 - 335	7 - 13	7 - 13	7 - 11	18 - 28
	3.0	100 - 115	305 - 345			4 - 8	20 - 30
70	1.5	127 - 141	325 - 365	10 - 16	3 - 8	12 - 16	24 - 36
	3.0	132 - 146	335 - 375			6 - 10	26 - 38
90	1.5	159 - 179	355 - 395	15 - 22	3 - 8	12 - 18	28 - 40
	3.0	164 - 184	365 - 405			7 - 11	30 - 42
110	1.5						
	3.0						

Note: Cooling performance based on entering air temperatures of 80° F DB, 67° F WB.

Heating performance based on entering air temperature of 70° F DB.

7/24/2014

# 060 Unit Operating Parameters

## Dual Capacity Models First Stage Operation

Entering Water Temp °F	Water Flow gpm/ton	Cooling -- No Hot Water Generation					
		Suction Pressure psig	Discharge Pressure psig	Superheat	Subcooling	Water Temp Rise °F	Air Temp Drop °F DB
30	1.5	99 - 113	141 - 155	40 - 50	8 - 15	14 - 19	13 - 21
	3.0	96 - 110	136 - 148			5 - 10	13 - 21
50	1.5	131 - 146	210 - 240	13 - 19	5 - 12	15 - 20	17 - 25
	3.0	128 - 143	185 - 215			6 - 11	17 - 25
70	1.5	136 - 150	265 - 295	8 - 14	5 - 12	15 - 20	17 - 25
	3.0	134 - 148	245 - 275			6 - 11	17 - 25
90	1.5	143 - 165	345 - 375	6 - 12	5 - 12	13 - 19	17 - 25
	3.0	140 - 155	325 - 355			5 - 10	17 - 25
110	1.5	147 - 162	435 - 465	6 - 12	5 - 12	13 - 19	17 - 25
	3.0	145 - 160	420 - 450			5 - 10	17 - 25

Entering Water Temp °F	Water Flow gpm/ton	Heating -- No Hot Water Generation					
		Suction Pressure psig	Discharge Pressure psig	Superheat	Subcooling	Water Temp Drop °F	Air Temp Rise °F DB
30	1.5	71 - 81	295 - 325	6 - 12	9 - 15	5 - 9	15 - 25
	3.0	75 - 85	300 - 330			2.5 - 6	16 - 26
50	1.5	100 - 115	315 - 345	7 - 13	9 - 15	5 - 9	18 - 28
	3.0	105 - 120	325 - 355			3 - 7	20 - 30
70	1.5	123 - 147	350 - 380	10 - 16	9 - 15	8 - 14	24 - 36
	3.0	128 - 142	355 - 385			5 - 9	26 - 38
90	1.5	165 - 185	370 - 410	14 - 20	7 - 13	9 - 14	28 - 40
	3.0	175 - 190	380 - 420			6 - 10	30 - 42
110	1.5						
	3.0						

Note: Cooling performance based on entering air temperatures of 80° F DB, 67° F WB.  
Heating performance based on entering air temperature of 70° F DB.

## Second Stage Operation

Entering Water Temp °F	Water Flow gpm/ton	Cooling -- No Hot Water Generation					
		Suction Pressure psig	Discharge Pressure psig	Superheat	Subcooling	Water Temp Rise °F	Air Temp Drop °F DB
30	1.5	88 - 103	144 - 164	45 - 55	8 - 15	17 - 23	15 - 23
	3.0	85 - 100	141 - 161			7 - 11	15 - 23
50	1.5	115 - 130	220 - 250	24 - 30	8 - 15	18 - 24	17 - 25
	3.0	113 - 128	195 - 225			8 - 12	17 - 25
70	1.5	126 - 141	295 - 325	10 - 16	8 - 15	18 - 24	17 - 25
	3.0	123 - 138	265 - 295			8 - 12	17 - 25
90	1.5	130 - 145	365 - 395	6 - 12	8 - 15	18 - 24	17 - 25
	3.0	128 - 143	335 - 370			8 - 12	17 - 25
110	1.5	137 - 152	445 - 485	6 - 12	8 - 15	17 - 23	17 - 25
	3.0	135 - 150	430 - 470			8 - 11	17 - 25

Entering Water Temp °F	Water Flow gpm/ton	Heating -- No Hot Water Generation					
		Suction Pressure psig	Discharge Pressure psig	Superheat	Subcooling	Water Temp Drop °F	Air Temp Rise °F DB
30	1.5	59 - 74	305 - 340	6 - 12	14 - 19	5 - 10	17 - 26
	3.0	63 - 78	315 - 350			3 - 7	18 - 28
50	1.5	90 - 105	335 - 375	7 - 13	11 - 16	7 - 11	23 - 33
	3.0	95 - 110	340 - 380			4 - 8	25 - 35
70	1.5	112 - 127	370 - 410	10 - 16	8 - 15	12 - 16	29 - 41
	3.0	117 - 132	380 - 420			5 - 9	31 - 43
90	1.5	160 - 180	410 - 450	15 - 22	7 - 13	12 - 18	36 - 48
	3.0	165 - 185	420 - 460			7 - 11	38 - 50
110	1.5						
	3.0						

Note: Cooling performance based on entering air temperatures of 80° F DB, 67° F WB.  
Heating performance based on entering air temperature of 70° F DB.

7/24/2014

## 072 Unit Operating Parameters

### Dual Capacity Models First Stage Operation

Entering Water Temp °F	Water Flow gpm/ton	Cooling -- No Hot Water Generation					
		Suction Pressure psig	Discharge Pressure psig	Superheat	Subcooling	Water Temp Rise °F	Air Temp Drop °F DB
30	1.5	103 - 118	141 - 155	40 - 50	8 - 15	14 - 19	13 - 21
	3.0	100 - 115	136 - 148			5 - 10	13 - 21
50	1.5	131 - 146	210 - 240	20 - 26	7 - 13	15 - 20	17 - 25
	3.0	128 - 143	185 - 215			6 - 11	17 - 25
70	1.5	142 - 157	270 - 300	8 - 14	5 - 12	15 - 20	17 - 25
	3.0	140 - 155	250 - 280			6 - 11	17 - 25
90	1.5	146 - 168	345 - 375	6 - 12	5 - 12	13 - 19	17 - 25
	3.0	143 - 158	325 - 355			5 - 10	17 - 25
110	1.5	151 - 165	435 - 465	6 - 12	5 - 12	13 - 19	17 - 25
	3.0	149 - 163	420 - 450			5 - 10	17 - 25

Entering Water Temp °F	Water Flow gpm/ton	Heating -- No Hot Water Generation					
		Suction Pressure psig	Discharge Pressure psig	Superheat	Subcooling	Water Temp Drop °F	Air Temp Rise °F DB
30	1.5	76 - 86	295 - 325	6 - 12	13 - 20	5 - 9	15 - 25
	3.0	80 - 90	300 - 330			2.5 - 6	16 - 26
50	1.5	105 - 120	315 - 345	7 - 13	13 - 20	5 - 9	18 - 28
	3.0	110 - 125	325 - 355			3 - 7	23 - 33
70	1.5	143 - 167	360 - 390	7 - 13	13 - 20	8 - 14	27 - 39
	3.0	148 - 162	365 - 395			5 - 9	29 - 41
90	1.5	180 - 200	380 - 420	8 - 14	10 - 16	9 - 14	33 - 45
	3.0	190 - 205	390 - 430			7 - 11	35 - 47
110	1.5						
	3.0						

Note: Cooling performance based on entering air temperatures of 80° F DB, 67° F WB.  
Heating performance based on entering air temperature of 70° F DB.

### Second Stage Operation

Entering Water Temp °F	Water Flow gpm/ton	Cooling -- No Hot Water Generation					
		Suction Pressure psig	Discharge Pressure psig	Superheat	Subcooling	Water Temp Rise °F	Air Temp Drop °F DB
30	1.5	91 - 106	144 - 164	45 - 55	12 - 18	16 - 22	13 - 21
	3.0	88 - 103	141 - 161			6 - 10	13 - 21
50	1.5	115 - 130	220 - 250	30 - 40	12 - 18	18 - 24	15 - 23
	3.0	113 - 128	195 - 225			8 - 12	15 - 23
70	1.5	130 - 145	290 - 320	14 - 20	8 - 15	18 - 24	17 - 25
	3.0	127 - 142	260 - 290			8 - 12	17 - 25
90	1.5	135 - 150	365 - 395	11 - 17	8 - 15	18 - 24	17 - 25
	3.0	133 - 148	335 - 370			8 - 12	17 - 25
110	1.5	142 - 157	445 - 485	11 - 17	8 - 15	17 - 23	15 - 23
	3.0	140 - 155	430 - 470			8 - 11	15 - 23

Entering Water Temp °F	Water Flow gpm/ton	Heating -- No Hot Water Generation					
		Suction Pressure psig	Discharge Pressure psig	Superheat	Subcooling	Water Temp Drop °F	Air Temp Rise °F DB
30	1.5	68 - 83	305 - 340	6 - 12	18 - 24	5 - 10	17 - 26
	3.0	72 - 87	315 - 350			3 - 7	18 - 28
50	1.5	98 - 113	335 - 375	8 - 14	17 - 23	7 - 11	23 - 33
	3.0	103 - 118	340 - 380			4 - 8	25 - 35
70	1.5	135 - 150	365 - 405	10 - 16	14 - 20	10 - 14	29 - 41
	3.0	140 - 155	375 - 415			6 - 10	31 - 43
90	1.5	165 - 185	405 - 445	15 - 22	14 - 20	12 - 18	36 - 48
	3.0	170 - 190	415 - 455			7 - 11	38 - 50
110	1.5						
	3.0						

Note: Cooling performance based on entering air temperatures of 80° F DB, 67° F WB.  
Heating performance based on entering air temperature of 70° F DB.

7/24/2014

## Pressure Drop

Model	GPM	Pressure Drop (psi)				
		30°F	50°F	70°F	90°F	110°F
<b>024 Full Load</b>	4	2.3	2.1	2.0	1.9	1.7
	6	4.5	4.3	4.0	3.7	3.5
	8	7.5	7.0	6.6	6.1	5.7
	10	10.5	9.7	9.9	8.5	7.9
<b>024 Part Load</b>	3	1.5	1.4	1.3	1.2	1.1
	5	3.3	3.1	2.9	2.7	2.5
	7	5.9	5.6	5.2	4.8	4.5
	9	8.5	8.1	8.2	6.9	6.5
<b>036 Full Load</b>	5	1.9	1.8	1.7	1.6	1.5
	7	3.6	3.4	3.2	3.0	2.9
	9	5.8	5.4	5.1	4.8	4.6
	11	8.0	7.4	7.4	6.6	6.3
<b>036 Part Load</b>	4	1.4	1.3	1.2	1.2	1.0
	6	2.7	2.6	2.4	2.3	2.1
	8	4.7	4.4	4.1	4.0	3.5
	10	6.7	6.2	6.2	5.7	4.9
<b>048 Full Load</b>	6	1.7	1.6	1.5	1.4	1.3
	9	3.9	3.6	3.4	3.2	3.1
	12	7.0	6.6	6.2	5.8	5.6
	15	10.1	9.6	9.8	8.4	8.1
<b>048 Part Load</b>	5	1.1	1.1	1.0	0.9	0.9
	8	3.1	2.9	2.7	2.5	2.3
	11	5.9	5.6	5.2	4.8	4.5
	14	8.7	8.3	8.5	7.1	6.7
<b>060 Full Load</b>	8	2.8	2.7	2.5	2.3	2.2
	12	5.8	5.4	5.1	4.8	4.4
	16	9.8	9.2	8.6	8.0	7.4
	20	13.8	13.0	13.0	11.2	10.4
<b>060 Part Load</b>	6	1.7	1.6	1.5	1.4	1.3
	10	4.2	4.0	3.7	3.4	3.2
	14	7.6	7.2	6.7	6.2	5.8
	18	11.0	10.4	10.7	9.0	8.4
<b>072 Full Load</b>	12	3.8	3.6	3.4	3.1	2.9
	15	5.7	5.3	5.0	4.7	4.3
	18	7.8	7.4	6.9	6.4	6.0
	21	9.9	9.5	9.1	8.1	7.7
<b>072 Part Load</b>	10	2.8	2.7	2.5	2.3	2.2
	13	4.4	4.2	3.9	3.6	3.4
	16	6.4	6.0	5.6	5.2	4.8
	19	8.4	7.8	7.6	6.8	6.2

7/18/14

## Thermistor Resistance

Thermistor Temperature (°F)	Microprocessor Resistance (Ohms)
5	75757-70117
14	57392-53234
23	43865-40771
32	33809-31487
41	26269-24513
50	20570-19230
59	16226-15196
68	12889-12093
77	10310-9688
86	8300-7812
95	6723-6337
104	5480-5172
113	4490-4246
122	3700-3504
131	3067-2907
140	2554-2424
149	2149-2019

7/21/14

## Compressor Resistance

Model	Compressor Model No.	208-230/60/1	
		Run	Start
024	ZPS20K5E-PFV	1.21 - 1.39	1.52 - 1.75
036	ZPS30K5E-PFV	0.81 - 0.94	1.41 - 1.63
048	ZPS40K5E-PFV	0.48 - 0.55	1.72 - 1.99
060	ZPS51K5E-PFV	0.36 - 0.42	1.51 - 1.74
072	ZPS60K5E-PFV	0.31 - 0.36	1.72 - 1.98

Note: Resistance at 77°F

7/21/2014

## Refrigerant Circuit Guideline

Symptom	Head Pressure	Suction Pressure	Compressor Amp Draw	Superheat	Subcooling	Air Temp. Differential	Water Temp. Differential
Under Charged System (Possible Leak)	Low	Low	Low	High	Low	Low	Low
Over Charged System	High	High	High	Normal	High	Normal/Low	Normal
Low Air Flow Heating	High	High	High	High/Normal	Low	High	Low
Low Air Flow Cooling	Low	Low	Low	Low/Normal	High	High	Low
Low Water Flow Heating	Low/Normal	Low/Normal	Low	Low	High	Low	High
Low Water Flow Cooling	High	High	High	High	Low	Low	High
High Air Flow Heating	Low	Low	Low	Low	High	Low	Low
High Air Flow Cooling	Low	High	Normal	High	Low	Low	Normal
High Water Flow Heating	Normal	Low	Normal	High	Normal	Normal	Low
High Water Flow Cooling	Low	Low	Low	Low	High	Normal	Low
Low Indoor Air Temperature Heating	Low	Low	Low	Normal	High	Normal	Normal/High
Low Indoor Air Temperature Cooling	Low	Low	Low	Normal/Low	High	Low	Low
High Indoor Air Temperature Heating	High	High	High	Normal/High	Normal/Low	Low	Normal
High Indoor Air Temperature Cooling	High	High	High	High	Low	Low	High
Restricted TXV (Check Service Advisory)	High	Low	Normal/Low	High	High	Low	Low
Insufficient Compressor (Possible Bad Valves)	Low	High	Low	High	Normal/High	Low	Low
TXV - Bulb Loss of Charge	Low	Low	Low	High	High	Low	Low
Scaled Coaxial Heat Exchanger Heating	Low	Low	Low	Normal/Low	High	Low	Low
Scaled Coaxial Heat Exchanger Cooling	High	High	High	Normal/Low	Low	Low	Low
Restricted Filter Drier	Check temperature difference (delta T) across filter drier.						



## Heat of Extraction/Rejection

Model		GPM	Heat of Extraction (kBtuh)				Heat of Rejection (kBtuh)				
			30°F	50°F	70°F	90°F	30°F	50°F	70°F	90°F	110°F
024	Part Load	3.0		12.6	16.1	20.1		21.1	20.8	20.1	
		5.0	9.2	13.2	17.4	21.4	20.3	21.2	20.9	20.1	19.4
		7.0	10.0	13.9	17.8	21.4	20.5	21.5	21.1	20.3	19.5
	Full Load	4.0		17.7	21.9	25.8		29.8	29.2	27.9	
		6.0	13.5	18.4	23.1	27.5	28.7	30.0	29.5	28.4	27.0
		8.0	13.9	18.9	23.8	28.5	28.9	30.2	29.7	28.5	27.1
036	Part Load	4.0		18.7	24.7	31.1		34.0	32.9	31.7	
		6.0	13.4	19.5	26.1	33.1	29.7	34.2	33.0	31.8	30.1
		8.0	14.5	20.6	26.8	33.1	29.9	34.6	33.4	32.1	30.4
	Full Load	5.0		26.6	33.1	39.2		45.3	45.0	42.9	
		7.0	20.5	27.7	34.9	41.8	40.3	45.7	45.5	43.7	41.3
		9.0	21.0	28.4	36.0	43.3	40.6	46.0	45.8	43.9	41.5
048	Part Load	5.0		23.5	29.1	34.6		45.0	44.9	43.1	
		8.0	18.9	25.9	32.1	38.5	39.3	45.1	44.7	42.5	40.7
		11.0	19.5	26.9	33.8	41.0	39.6	45.1	45.0	43.2	41.7
	Full Load	6.0		31.6	39.2	46.3		63.2	63.2	60.6	
		9.0	25.7	34.9	43.4	51.7	55.8	62.9	62.6	59.7	56.4
		12.0	26.6	36.2	45.8	55.1	56.1	62.7	62.9	60.7	57.7
060	Part Load	6.0		31.3	39.5	47.1		56.3	54.8	52.5	
		10.0	21.5	31.6	41.2	50.8	46.2	56.1	54.8	52.8	49.0
		14.0	22.6	32.8	42.1	50.9	46.5	56.1	55.0	53.1	49.3
	Full Load	8.0		39.7	51.8	63.6		73.1	74.3	72.9	
		12.0	30.7	42.6	54.2	64.7	63.4	73.5	74.7	73.1	69.4
		16.0	31.0	43.5	55.9	67.4	63.8	73.9	75.0	73.5	69.5
072	Part Load	10.0		40.7	52.2	63.1		67.9	68.0	63.3	
		13.0	28.5	41.0	54.5	68.1	55.8	67.7	67.9	63.5	60.6
		16.0	30.2	42.7	55.5	68.1	56.2	67.6	68.2	63.8	61.0
	Full Load	12.0		51.0	66.0	80.7		83.1	87.8	84.5	
		15.0	40.2	54.5	68.8	81.9	69.5	83.4	88.1	84.8	82.1
		18.0	40.7	55.6	71.0	85.3	69.9	83.9	88.7	85.2	82.3

Note: operation not recommended in shaded areas.

7/21/14

# Correction Factor Tables

## Air Flow Corrections (Dual Capacity Part Load)

Airflow		Cooling				Heating		
cfm Per Ton of Clg	% of Nominal	Total Cap	Sens Cap	Power	Heat of Rej	Htg Cap	Power	Heat of Ext
240	60	0.922	0.778	0.956	0.924	0.943	1.239	0.879
275	69	0.944	0.830	0.962	0.944	0.958	1.161	0.914
300	75	0.957	0.866	0.968	0.958	0.968	1.115	0.937
325	81	0.970	0.900	0.974	0.970	0.977	1.075	0.956
350	88	0.982	0.933	0.981	0.980	0.985	1.042	0.972
375	94	0.991	0.968	0.991	0.991	0.993	1.018	0.988
<b>400</b>	<b>100</b>	<b>1.000</b>	<b>1.000</b>	<b>1.000</b>	<b>1.000</b>	<b>1.000</b>	<b>1.000</b>	<b>1.000</b>
425	106	1.007	1.033	1.011	1.008	1.007	0.990	1.010
450	113	1.013	1.065	1.023	1.015	1.012	0.987	1.018
475	119	1.017	1.099	1.037	1.022	1.018	0.984	1.025
500	125	1.020	1.132	1.052	1.027	1.022	0.982	1.031
520	130	1.022	1.159	1.064	1.030	1.025	0.979	1.034

5/30/06

## Air Flow Corrections (Dual Capacity Full Load)

Airflow		Cooling				Heating		
cfm Per Ton of Clg	% of Nominal	Total Cap	Sens Cap	Power	Heat of Rej	Htg Cap	Power	Heat of Ext
240	60	0.922	0.786	0.910	0.920	0.943	1.150	0.893
275	69	0.944	0.827	0.924	0.940	0.958	1.105	0.922
300	75	0.959	0.860	0.937	0.955	0.968	1.078	0.942
325	81	0.971	0.894	0.950	0.967	0.977	1.053	0.959
350	88	0.982	0.929	0.964	0.978	0.985	1.031	0.973
375	94	0.992	0.965	0.982	0.990	0.993	1.014	0.988
<b>400</b>	<b>100</b>	<b>1.000</b>	<b>1.000</b>	<b>1.000</b>	<b>1.000</b>	<b>1.000</b>	<b>1.000</b>	<b>1.000</b>
425	106	1.007	1.034	1.020	1.010	1.007	0.990	1.011
450	113	1.012	1.065	1.042	1.018	1.013	0.983	1.020
475	119	1.017	1.093	1.066	1.026	1.018	0.980	1.028
500	125	1.019	1.117	1.092	1.033	1.023	0.978	1.034
520	130	1.020	1.132	1.113	1.038	1.026	0.975	1.038

5/30/06

## Cooling Capacity Corrections

Entering Air WB °F	Total Clg Cap	Sensible Cooling Capacity Multipliers - Entering DB °F										Power Input	Heat of Rejection
		60	65	70	75	80	80.6	85	90	95	100		
55	0.898	0.723	0.866	1.048	1.185	*	*	*	*	*	*	0.985	0.913
60	0.912		0.632	0.880	1.078	1.244	1.260	*	*	*	*	0.994	0.927
63	0.945			0.768	0.960	1.150	1.175	*	*	*	*	0.996	0.954
65	0.976			0.694	0.881	1.079	1.085	1.270	*	*	*	0.997	0.972
66.2	0.983			0.655	0.842	1.040	1.060	1.232	*	*	*	0.999	0.986
<b>67</b>	<b>1.000</b>			0.616	0.806	<b>1.000</b>	1.023	1.193	1.330	1.480	*	<b>1.000</b>	<b>1.000</b>
70	1.053				0.693	0.879	0.900	1.075	1.205	1.404	*	1.003	1.044
75	1.168					0.687	0.715	0.875	1.040	1.261	1.476	1.007	1.141

NOTE: \* Sensible capacity equals total capacity at conditions shown.

3/28/12

## Heating Capacity Corrections

Ent Air DB °F	Heating Corrections		
	Htg Cap	Power	Heat of Ext
45	1.062	0.739	1.158
50	1.050	0.790	1.130
55	1.037	0.842	1.096
60	1.025	0.893	1.064
65	1.012	0.945	1.030
68	1.005	0.976	1.012
<b>70</b>	<b>1.000</b>	<b>1.000</b>	<b>1.000</b>
75	0.987	1.048	0.970
80	0.975	1.099	0.930

11/10/09

## Antifreeze Corrections

Catalog performance can be corrected for antifreeze use. Please use the following table and note the example given.

Antifreeze Type	Antifreeze % by wt	Heating	Cooling	Pressure Drop
EWT - °F [°C]		30 [-1.1]	90 [32.2]	30 [-1.1]
Water	0	1.000	1.000	1.000
Ethylene Glycol	10	0.973	0.991	1.075
	20	0.943	0.979	1.163
	30	0.917	0.965	1.225
	40	0.890	0.955	1.324
	50	0.865	0.943	1.419
Propylene Glycol	10	0.958	0.981	1.130
	20	0.913	0.969	1.270
	30	0.854	0.950	1.433
	40	0.813	0.937	1.614
	50	0.770	0.922	1.816
Ethanol	10	0.927	0.991	1.242
	20	0.887	0.972	1.343
	30	0.856	0.947	1.383
	40	0.815	0.930	1.523
	50	0.779	0.911	1.639
Methanol	10	0.957	0.986	1.127
	20	0.924	0.970	1.197
	30	0.895	0.951	1.235
	40	0.863	0.936	1.323
	50	0.833	0.920	1.399



**WARNING:** Gray area represents antifreeze concentrations greater than 35% by weight and should be avoided due to the extreme performance penalty they represent.

### Antifreeze Correction Example

Antifreeze solution is Propylene Glycol 20% by weight. Determine the corrected heating and cooling performance at 30°F and 90°F respectively as well as pressure drop at 30°F for a 036.

The corrected cooling capacity at 90°F would be: 34,800 Btu/h x 0.969 = 33,721 Btu/h

The corrected heating capacity at 30°F would be: 29,300 Btu/h x 0.913 = 26,750 Btu/h

The corrected pressure drop at 30°F and 9 gpm would be: 13.4 feet of head x 1.270 = 17.02 feet of head

## Troubleshooting

### Aurora Control System

**NOTE:** Refer to the Aurora Base Control Application and Troubleshooting Guide and the Instruction Guide: Aurora Interface and Diagnostics (AID) Tool for additional information.

To check the unit control board for proper operation:

1. Disconnect thermostat wires at the control board.
2. Jumper the desired test input (Y1, Y2, W, O or G) to the R terminal to simulate a thermostat signal.
3. If control functions properly:
  - Check for thermostat and field control wiring (use the diagnostic inputs mode).
4. If control responds improperly:
  - Ensure that component being controlled is functioning (compressor, blower, reversing valve, etc.).
  - Ensure that wiring from control to the component is correct.

- Refer to the Aurora Base Control Application and Troubleshooting Guide and the Instruction Guide: Aurora Interface and Diagnostics (AID) Tool for additional information.

### Refrigerant Systems

To maintain sealed circuit integrity, do not install service gauges unless unit operation appears abnormal. Compare the change in temperature on the air side as well as the water side to the Unit Operating Parameters tables. If the unit's performance is not within the ranges listed, and the airflow and water flow are known to be correct, gauges should then be installed and superheat and subcooling numbers calculated. If superheat and subcooling are outside recommended ranges, an adjustment to the refrigerant charge may be necessary.

**NOTE:** Refrigerant tests must be made with hot water generator turned "OFF". Verify that air and water flow rates are at proper levels before servicing the refrigerant circuit.

## Troubleshooting cont.

### Startup/Troubleshooting Form

Dealer: \_\_\_\_\_ Controls Info: \_\_\_\_\_  
 Phone #: \_\_\_\_\_ Date: \_\_\_\_\_ ABC Version: \_\_\_\_\_  
 Problem: \_\_\_\_\_ IZ2 24V Version: \_\_\_\_\_  
 Model #: \_\_\_\_\_ T-Stat Version: \_\_\_\_\_  
 Serial #: \_\_\_\_\_ Installed Sensors: \_\_\_\_\_

### COOLING CYCLE ANALYSIS

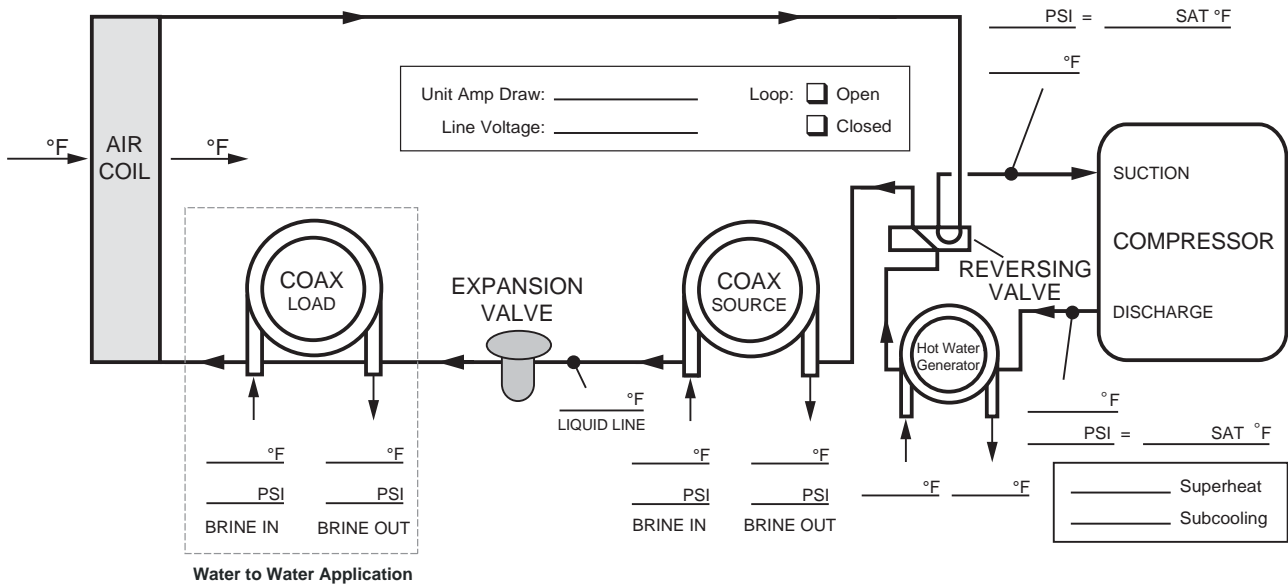

**Heat of Extraction/Rejection = gpm x 500 (485 for water/antifreeze) x ΔT**

**Note: DO NOT** hook up pressure gauges unless there appears to be a performance problem.

### HEATING CYCLE ANALYSIS

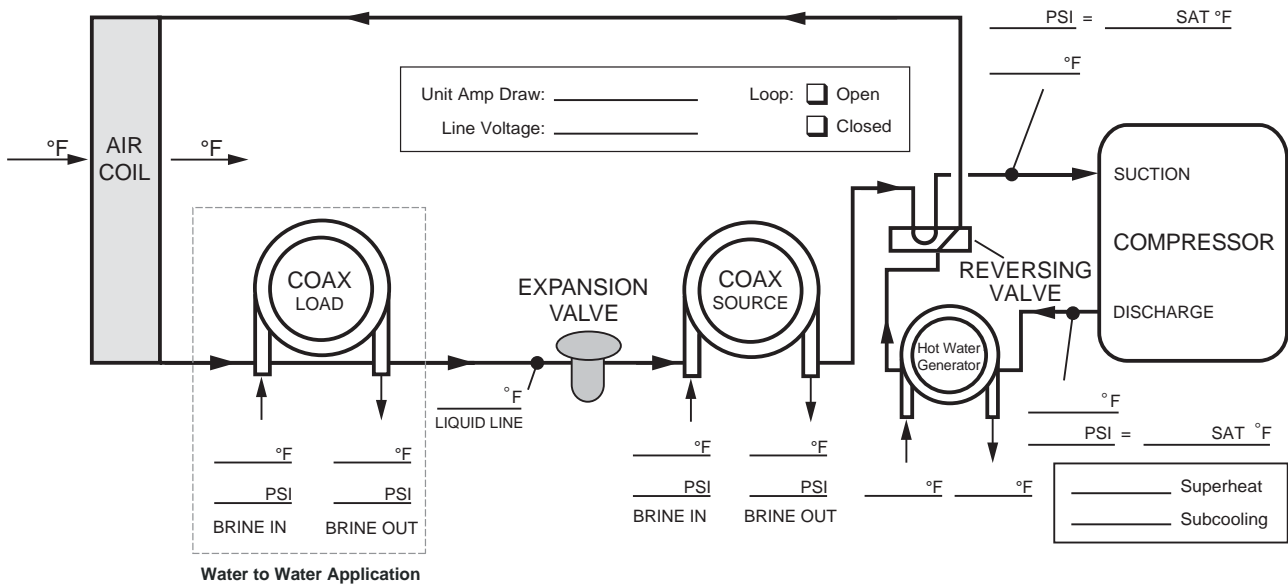

# Troubleshooting cont.

## Single Speed/Dual Capacity Startup/Troubleshooting Form

### 1. Job Information

Model # \_\_\_\_\_ Job Name: \_\_\_\_\_ Loop: Open / Closed  
 Serial # \_\_\_\_\_ Install Date: \_\_\_\_\_ Hot Water Generator: Y / N

### 2. Flow Rate in gpm

	SOURCE COAX		LOAD COAX (Water-to-Water)	
	HEATING	COOLING	HEATING	COOLING
WATER IN Pressure:	a. _____ psi	a. _____ psi	a. _____ psi	a. _____ psi
WATER OUT Pressure:	b. _____ psi	b. _____ psi	b. _____ psi	b. _____ psi
Pressure Drop: a - b	c. _____ psi	c. _____ psi	c. _____ psi	c. _____ psi
Look up flow rate in table:	d. _____ gpm	d. _____ gpm	d. _____ gpm	d. _____ gpm

### 3. Temp. Rise/Drop Across Air Coil<sup>1</sup>

	HEATING	COOLING
SUPPLY AIR Temperature:	e. _____ °F	e. _____ °F
RETURN AIR Temperature:	f. _____ °F	f. _____ °F
Temperature Difference:	g. _____ °F	g. _____ °F

### 4. Temp. Rise/Drop Across Coaxial Heat Exchanger

	SOURCE COAX		LOAD COAX (Water-to-Water)	
	HEATING	COOLING	HEATING	COOLING
WATER IN Temperature:	h. _____ °F	h. _____ °F	h. _____ °F	h. _____ °F
WATER OUT Temperature:	i. _____ °F	i. _____ °F	i. _____ °F	i. _____ °F
Temperature Difference:	j. _____ °F	j. _____ °F	j. _____ °F	j. _____ °F

### 5. Heat of Rejection (HR)/Heat of Extraction (HE)

Brine Factor<sup>2</sup>: k. \_\_\_\_\_  
 HR/HE = d x j x k  
 HEATING: l. \_\_\_\_\_ Btu/h  
 COOLING: l. \_\_\_\_\_ Btu/h

### STEPS 6-9 NEED ONLY BE COMPLETED IF A PROBLEM IS SUSPECTED.

### 6. Watts

	ENERGY MONITOR	
	HEATING	COOLING
Volts:	m. _____ Volts	m. _____ Volts
Total Amps (Comp. + Blower) <sup>3</sup> :	n. _____ Amps	n. _____ Amps
Watts = m x n x 0.85:	o. _____ Watts	o. _____ Watts

### 7. Capacity

	HEATING	COOLING
Cooling Capacity = l - (o x 3.413):	p. _____ Btu/h	p. _____ Btu/h
Heating Capacity = l + (o x 3.413):		

### 8. Efficiency

	HEATING	COOLING
Cooling EER = p / o:	q. _____ Btu/h	q. _____ Btu/h
Heating COP = p / (o x 3.413):		

### 9. Superheat (S.H.)/Subcooling (S.C.)

	HEATING	COOLING
Suction Pressure:	r. _____ psi	r. _____ psi
Suction Saturation Temperature:	s. _____ °F	s. _____ °F
Suction Line Temperature:	t. _____ °F	t. _____ °F
S.H. = t - s	u. _____ °F	u. _____ °F
Head Pressure:	v. _____ psi	v. _____ psi
High Pressure Saturation Temp:	w. _____ °F	w. _____ °F
Liquid Line Temperature <sup>4</sup> :	x. _____ °F	x. _____ °F
S.C. = w - x	y. _____ °F	y. _____ °F

Software Version
ABC: _____
IZZ: _____
T'STAT: _____

**NOTES:** <sup>1</sup> Steps 3-9 should be conducted with the hot water generator disconnected.  
<sup>2</sup> Use 500 for pure water, 485 for methanol or Environol™. (This constant is derived by multiplying the weight of one gallon of water (8.34) times the minutes in one hour (60) times the specific heat of the fluid. Water has a specific heat of 1.0.)  
<sup>3</sup> If there is only one source of power for the compressor and blower, amp draw can be measured at the source wiring connection.  
<sup>4</sup> Liquid line is between the coax and the expansion device in the cooling mode; between the air coil and the expansion device in the heating mode.

## Preventive Maintenance

---

Proper maintenance is very important to obtain optimum performance and longevity for the heat pump system. It is best to establish a periodic maintenance schedule with the installer so the heat pump system can be checked regularly.

### Water Coil Maintenance

1. Keep all air out of the water. An open loop system should be checked to ensure that the well head is not allowing air to infiltrate the water line. Lines should always be airtight.
2. Keep the system under pressure at all times. It is recommended in open loop systems that the water control valve be placed in the discharge line to prevent loss of pressure during off cycles. Closed loop systems must have positive static pressure.

**NOTE:** On open loop systems, if the installation is in an area with a known high mineral content (125 PPM or greater) in the water, it is best to establish with the owner a periodic maintenance schedule so the coil can be checked regularly. Should periodic coil cleaning be necessary, use standard coil cleaning procedures which are compatible with the heat exchanger and copper water lines. Generally, the more water flowing through the unit the less chance for scaling. However, flow rates above 3gpm/ton may erode the heat exchanger or water lines, due to high water velocity or system debris.

### Other Maintenance

#### Filters

Filters must be clean to obtain maximum performance. They should be inspected monthly under normal operating conditions and be replaced when necessary. Units should never be operated without a filter. Operating the system without a filter or with a dirty filter could affect the longevity of the heat pump.

### Condensate Drain

In areas where airborne bacteria produce a slime in the drain pan, it may be necessary to treat chemically to minimize the problem. The condensate drain can pick up lint and dirt, especially with dirty filters. Inspect twice a year to avoid the possibility of overflow.

### Blower Motors

ECM blower motors are equipped with sealed ball bearings and require no periodic oiling.

### Hot Water Generator Coil

See Water Coil Maintenance section above.

### Air Coil

The air coil must be cleaned to obtain maximum performance. Check once a year under normal operating conditions and, if dirty, brush or vacuum (with a brush attachment) clean. Care must be taken not to damage the aluminum fins while cleaning.



**CAUTION: Fin edges are sharp.**

## Replacement Procedures

---

### Obtaining Parts

When ordering service or replacement parts, refer to the model number and serial number of the unit as stamped on the serial plate attached to the unit. If replacement parts are required, mention the date of installation of the unit and the date of failure, along with an explanation of the malfunctions and a description of the replacement parts required.

### In-Warranty Material Return

Material may not be returned except by permission of authorized warranty personnel. Contact your local distributor for warranty return authorization and assistance.

## Service Parts List

Parts List		Dual Capacity Units				
		024	036	048	060	072
Compressor	Compressor 208-230/60/1	34P640-01	34P641-01	34P642-01	34P643-01	34P644-01
	Run Capacitor 208-230/60/1	16P002D19	16P002D20	16P002D18	16P002D31	16P002D31
	Power Harness	11P781-01	11P781-01	11P781-01	11P781-01	11P781-01
	Solenoid Harness	11P782-02	11P782-02	11P782-02	11P782-02	11P782-02
5 Speed ECM Motor & Blower	5 Speed ECM Motor 208-230/60/1	14S536-12	14S536-03	14S537-01	14S537-07	14S537-03
	5 Speed ECM Blower Housing	53P500B01	53P500B01	53P501B01	53P501B01	53P501B01
Air Filters	1" Air Filters (Horizontal Model) and Second Filter If Needed	59B503B07	59B503B23	59B503B08	59B503B08	59B503B02
		n/a	n/a	n/a	n/a	59B503B24
	1" Air Filters (Vertical Model)	59P503B12	59P503B27	59P503B28	59P503B28	59P503B21
Refrigeration Components	Air Coil (Vertical Model)	61P721-41	61P705-41	61P706-41	61P706-41	61P715-41
	Air Coil Coated (Vertical Model)	61S721-42	61S705-42	61S706-42	61S706-42	61S715-42
	Air Coil (Horizontal Model)	61P720-41	61P707-41	61P709-41	61P709-41	61P710-41
	Air Coil Coated (Horizontal Model)	61S720-42	61S707-42	61S709-42	61S709-42	61S710-42
	Coax	62I592-01	62I594-01	62I568-01	62I542A01	62I543A01
	TXV	33P619-10	33P619-11	33P619-12	33P619-13	33P619-14
	Reversing Valve	33P506-04	33P506-04	33P526-05	33P526-05	33P526-05
	Discharge Muffler	36P503B02	36P503B02	36P503B02	36P503B02	36P503B02
Filter Dryer	36P500B01	36P500B01	36P500B01	36P500B02	36P500B02	
Hot Water Generator	Hot Water Generator	62P516-05	62P516-05	62P516-03	62P516-03	62P516-03
	Hot Water Generator Pump	24P501A01	24P501A01	24P501A01	24P501A01	24P501A01
Electrical	Contactors	13P004A03	13P004A03	13P004A03	13P004A03	13P004A03
	Transformer 208-230/60/1	15P501B01	15P501B01	15P501B01	15P501B01	15P501B01
	3 Pole Power Block	12P503-06	12P503-06	12P503-06	12P503-06	12P503-06
	2 Pole Screw Term. Block	12P500A01	12P500A01	12P500A01	12P500A01	12P500A01
	ABC Board	17X553-07	17X553-07	17X553-07	17X553-07	17X553-07
	Keystone Category 5 Coupler (AID Port)	12P553-01	12P553-01	12P553-01	12P553-01	12P553-01
	Category 5 cable (AID Port to ABC)	11P846-01	11P846-01	11P846-01	11P846-01	11P846-01
	Rocker Switch - HWG ON/OFF	13P607A01	13P607A01	13P607A01	13P607A01	13P607A01
Pump Circuit Breaker - 5 amp, 250v	19P583-01	19P583-01	19P583-01	19P583-01	19P583-01	
Sensors & Safeties	Thermistor, Low Water Coil Limit (FP1)	12P505-09	12P505-09	12P505-09	12P505-09	12P505-09
	HW Thermo-switch SPNC 130°F	13P073B05	13P073B05	13P073B05	13P073B05	13P073B05
	High Pressure Switch Kit	SKHPE600	SKHPE600	SKHPE600	SKHPE600	SKHPE600
	Low Pressure Switch Kit	SKLPE40	SKLPE40	SKLPE40	SKLPE40	SKLPE40

Part numbers subject to change

12/14/16

## Notes

---



---

## Revision Guide

---

<b>Pages:</b>	<b>Description:</b>	<b>Date:</b>	<b>By:</b>
Misc.	Updated AHRI Data, Misc. Updates	01 Feb 2018	JM
Misc.	Updated Physical Data, Wiring Schematics, Controls Information	14 Dec 2016	MA
All	Document Creation	17 Sept 2014	MA

Product: **LX Series**  
Type: Dual Speed Geothermal Heat Pumps  
Size: 2-6 Tons

Document Type: Installation Manual  
Part Number: IM2300AK6  
Release Date: 03/18



©2018 The manufacturer has a policy of continual product research and development and reserves the right to change design and specifications without notice.

York and Affinity are registered trademarks of Johnson Controls, Inc., and are used with permission.

IM2300AK6 03/18