

OPERATION & MAINTENANCE

Affinity Series

Dual-Capacity Hydronic Heat Pump

60Hz / R-454B

 **YORK**[®]

OMW5-0026Y



 **WARNING**



WARNING: Before performing service or maintenance operations on the system, turn off main power switches to the unit. Electrical shock could cause serious personal injury.

WARNING: All products are designed, tested, and manufactured to comply with the latest publicly released and available edition of UL 60335-2-40 for electrical safety certification. All field electrical connections must follow the National Electrical Code (NEC) guide standards and / or any local codes that may be applicable for the installation.

WARNING: Only factory authorized personnel are approved for startup, check test and commissioning of this unit.

INSTALLER: Please take the time to read and understand these instructions prior to any installation. Installer must give a copy of this manual to the owner.

Definition of Warnings and Symbols

 DANGER	Indicates a situation that results in death or serious injury.
 WARNING	Indicates a situation that could result in death or serious injury.
 CAUTION	Indicates a situation that could result in minor or moderate injury.
NOTICE	Indicates a situation that could result in equipment or property damage.

For the User

 **WARNING**

This appliance is not intended for use by persons (including children) with reduced physical, sensory, or mental capabilities, or lack of experience and knowledge, unless they have been given supervision or instruction concerning use of the appliance by a person responsible for their safety.

Children should be supervised to ensure that they do not play with the appliance.

Keep this manual in a safe place in order to provide your serviceman with necessary information.

NOTICE

NOTICE: To avoid equipment damage, do not leave the system filled in a building without heat during cold weather, unless adequate freeze protection levels of antifreeze are used. Heat exchangers do not fully drain and will freeze unless protected, causing permanent damage.

Table of Contents

UNIT OVERVIEW

- General Installation Information 4
- Nomenclature 6
- AHRI Data 7
- Physical Data 9
- Dimensional Data 10
- Electrical Data 12

OPERATING PRINCIPLES

- Antifreeze Corrections 14
- Heat of Extraction/Heat of Rejection 15
- Water Quality 16
- Operating Parameters 17
- Pressure Drop 18
- Flow Rate 19
- Aurora Control System 20
- Hydrozone Controller Instructions 30

SERVICE AND TROUBLESHOOTING

- Compressor and Thermistor Resistance 38
- Reference Calculations and Legend 39
- Preventative Maintenance 40
- Troubleshooting 41
- Aurora Interface Diagnostic (AID) Tool 42
- Preliminary Checkout Procedure 42
- Troubleshooting Checklist 43
- Control Board Troubleshooting Steps 44
- Control Board Troubleshooting Flow Charts 46
- Communicating Thermostat Troubleshooting Guide 54
- Control Board Signals 56
- Jumping the Control Board 59
- Troubleshooting 61
- Troubleshooting Forms 63
- Performance Data 64
- Service Parts Table 68
- Decommissioning 69
- Decommissioning Unit Labeling Requirements 69
- Refrigerant Recovery 70
- Refrigerant Removal and Evacuation 70
- Charging Procedures 71

REVISION GUIDE 73

General Installation Information

NOTICE: Do not store or install units in corrosive environments or in locations subject to temperature or humidity extremes. Corrosive conditions and high temperature or humidity can significantly reduce performance, reliability, and service life.

NOTICE: A minimum of 24 in. clearance should be allowed for access to front access panel.

NOTICE: To avoid equipment damage, DO NOT use these units as a source of heating or cooling during the construction process. The mechanical components and filters can quickly become clogged with construction dirt and debris, which may cause system damage and void product warranty.

For the Installer

If you are NOT sure how to install or operate the unit, contact your dealer.

Installing and servicing air conditioning and heating equipment can be hazardous due to system pressure and electrical components. Only trained and qualified service personnel should install, repair or service heating and air conditioning equipment. When working on heating and air conditioning equipment, observe precautions in the literature, tags and labels attached to the unit and other safety precautions that may apply.

This manual contains specific information about the required qualification of the working personnel for maintenance, service and repair operations. Every working procedure that affects safety means shall only be carried out by competent persons.

Examples for such working procedures are:

- breaking into the refrigerating circuit;
- opening of sealed components or ventilated enclosures.

Follow all safety codes. Wear safety glasses and work gloves. Use quenching cloth for brazing operations. Have fire extinguisher available for all brazing operations. Follow all procedures to remain in compliance with national gas regulations.

Prior to beginning work on systems containing FLAMMABLE REFRIGERANTS, safety checks are necessary to ensure that the risk of ignition is minimized. Work shall be undertaken under a controlled procedure so as to minimise the risk of a flammable gas or vapor being present while the work is being performed. All maintenance staff and others working in the local area shall be instructed on the nature of work being carried out. Work in confined spaces shall be avoided.

The area shall be checked with an appropriate refrigerant detector prior to and during work, to ensure the technician is aware of potentially toxic or flammable atmospheres. Ensure that the leak detection equipment being used is suitable for use with all applicable refrigerants, i.e. non-sparking, adequately sealed or intrinsically safe.

If any hot work is to be conducted on the refrigerating equipment or any associated parts, appropriate fire extinguishing equipment shall be available to hand. Have a dry powder or CO2 fire extinguisher adjacent to the charging area.

No person carrying out work in relation to a REFRIGERATING SYSTEM which involves exposing any pipe work shall use any sources of ignition in such a manner that it may lead to the risk of fire or explosion. All possible ignition sources, including cigarette smoking, should be kept sufficiently far away from the site of installation, repairing, removing and disposal, during which refrigerant can possibly be released to the surrounding space. Prior to work taking place, the area around the equipment is to be surveyed to make sure that there are no flammable hazards or ignition risks. "No Smoking" signs shall be displayed.

Where electrical components are being changed, they shall be fit for the purpose and to the correct specification. At all times the manufacturer's maintenance and service guidelines shall be followed. If in doubt, consult the manufacturer's technical department for assistance.

The following checks shall be applied to installations using FLAMMABLE REFRIGERANTS:

- the actual REFRIGERANT CHARGE is in accordance with the room size within which the refrigerant containing parts are installed;
- the ventilation machinery and outlets are operating adequately and are not obstructed;
- if an indirect refrigerating circuit is being used, the secondary circuit shall be checked for the presence of refrigerant;
- marking to the equipment continues to be visible and legible. Markings and signs that are illegible shall be corrected;
- refrigerating pipe or components are installed in a position where they are unlikely to be exposed to any substance which may corrode refrigerant containing components, unless the components are constructed of materials which are inherently resistant to being corroded or are suitably protected against being so corroded.

Instructions for Equipment Using R-454B Refrigerant

WARNING

- **Do NOT pierce or burn**
- **Do NOT use means to accelerate the defrosting process or to clean the equipment, other than those recommended by the manufacturer**
- **Be aware that refrigerants may not contain an odor**

WARNING

- **The Appliance should be stored so as to prevent mechanical damage and in a room without continuously operating ignition sources (example: open flames, an operating gas appliance or an operating electric heater)**

General Installation Information

WARNING

Ventilated Area: ensure that the area is in the open or that it is adequately ventilated before breaking into the system of conducting any hot work. A degree of ventilation should continue during the period that the work is carried out. The ventilation should safely disperse any released refrigerant and preferably expel it. Keep ventilation area clear of obstructions!

WARNING

Do NOT use potential sources of ignition in searching for or detection of refrigerant leaks. A halide torch (or any other detector using a naked flame) shall not be used.

The following leak detection methods are deemed acceptable for all refrigerant systems. Electronic leak detectors may be used to detect refrigerant leaks but, in the case of FLAMMABLE REFRIGERANTS, the sensitivity may not be adequate, or may need re-calibration. (Detection equipment shall be calibrated in a refrigerant-free area.) Ensure that the detector is not a potential source of ignition and is suitable for the refrigerant used. Leak detection equipment shall be set at a percentage of the LFL of the refrigerant and shall be calibrated to the refrigerant employed, and the appropriate percentage of gas (25 % maximum) is confirmed. Leak detection fluids are also suitable for use with most refrigerants but the use of detergents containing chlorine shall be avoided as the chlorine may react with the refrigerant and corrode the copper pipe-work. NOTE Examples of leak detection fluids are bubble method, fluorescent method agents. If a leak is suspected, all naked flames shall be removed/extinguished. If a leakage of refrigerant is found which requires brazing, all of the refrigerant shall be recovered from the system, or isolated (by means of shut off valves) in a part of the system remote from the leak. Removal of refrigerant shall follow the procedure outlined in this manual.

Installation Site

This equipment has been evaluated to be installed up to a maximum altitude of 3000m (9843ft) and should not be installed at an altitude greater than 3000m. For installation only in locations not accessible to the general public.

WARNING

For appliances using A2L refrigerants connected via an air duct system to one or more rooms, only auxiliary devices approved by the appliance manufacturer or declared suitable with the refrigerant shall be installed in connecting ductwork. The manufacturer shall list in the instructions all approved auxiliary devices by manufacturer and model number for use with the specific appliance, if those devices have a potential to become an ignition source.

Installation Space Requirements

NOTE: Equipment with refrigerant charge less than 62 oz does not require have a minimum floor area requirement and does not require a refrigerant leak detection sensor. The sensor might be added as a feature.

WARNING

Equipment containing R-454B refrigerant shall be installed, operated, and stored in a room with floor area larger than the area defined in the "Minimum Floor Area" chart based on the total refrigerant charge in the system. This requirement applies to indoor equipment with or without a factory refrigerant leakage sensor.

CAUTION

It is not recommended to use a potable water source for this equipment water supply.

WARNING

This equipment comes with a factory installed Refrigerant Detection Device which is capable of determining it's specified end-of-life and replacement instructions. Refrigerant sensors for refrigerant detection systems shall only be replaced with sensors specified by the appliance manufacture.

WARNING

Take sufficient precautions in case of refrigerant leakage. If refrigerant gas leaks, ventilate the area immediately.
POSSIBLE RISKS: Excessive refrigerant concentrations in a closed room can lead to oxygen deficiency

WARNING

ALWAYS recover the refrigerant. Do NOT release them directly into the environment. Follow handling instructions carefully in compliance with national regulations.

WARNING

Check that cabling will not be subject to wear, corrosion, excessive pressure, vibration, sharp edges or any other adverse environmental effects. The check shall also take into account the effects of aging or continual vibration from sources such as compressors or fans.

AHRI Data

The performance standard AHRI/ASHRAE/ISO 13256-2 became effective January 1, 2000. This new standard has three major categories: Water Loop, Ground Water, and Ground Loop.

Unit of Measure: The Cooling COP

The cooling efficiency is measured in EER (US version measured in Btuh per Watt. The Metric version is measured in a cooling COP (Watt per Watt) similar to the traditional COP measurement.

Pump Power Correction Calculation

Within each model, only one water flow rate is specified for all three groups and pumping Watts are calculated using the following formula. This additional power is added onto the existing power consumption.

- Pump power correction = (gpm x 0.0631) x (Press Drop x 2990) / 300

Where 'gpm' is waterflow in gpm and 'Press Drop' is the pressure drop through the unit heat exchanger at rated water flow in feet of head.

ISO Capacity and Efficiency Calculations

The following equations illustrate cooling calculations:

- ISO Cooling Capacity = Cooling Capacity (Btuh) x 3.412

- ISO EER Efficiency (W/W) = ISO Cooling Capacity (Btuh) x 3.412 / [Power Input (Watts) + Pump Power Correction (Watt)]

The following equations illustrate heating calculations:

- ISO Heating Capacity = Heating Capacity (Btuh) x 3.412

- ISO COP Efficiency (W/W) = ISO Heating Capacity (Btuh) x 3.412 / [Power Input (Watts) + Pump Power Correction (Watt)]

Test Conditions

	ISO/AHRI 13256-2 WLHP	ISO/AHRI 13256-2 GWHP	ISO/AHRI 13256-2 GLHP
Cooling			
Liquid Entering Indoor Side - °F <i>Standard Rating Test</i>	53.6	53.6	53.6
Liquid Entering Heat Exchanger - °F <i>Part-load Rating Test</i>	86	59	77
Liquid Entering Heat Exchanger Fluid Flow Rate	86 *	59 *	68 *
Heating			
Liquid Entering Indoor Side - °F <i>Standard Rating Test</i>	104	104	104
Liquid Entering Outdoor-side Heat Exchanger - °F <i>Part-load Rating Test</i>	68	50	32
Liquid Entering Outdoor-side Heat Exchanger Fluid Flow Rate	68 *	50 *	41 *

NOTES: *Flow rate is specified by the manufacturer
 WLHP = Water Loop Heat Pump; GWHP = Ground Water Heat Pump;
 GLHP = Ground Loop Heat Pump

Conversions

Water Flow (lps) = GPM x 0.0631

Press Drop (Pascals) = Press Drop (ft hd) x 2990

AHRI Data

Model	Capacity Modulation	Flow Rate		Water Loop Heat Pump				Ground Water Heat Pump				Ground Loop Heat Pump			
				Cooling EST 86°F ELT 53.6°F		Heating EST 68°F ELT 104°F		Cooling EST 59°F ELT 53.6°F		Heating EST 50°F ELT 104°F		Cooling Full EST 77°F Part EST 68°F ELT 53.6°F		Heating Full EST 32°F Part ELT 41°F ELT 104°F	
		Sgpm	Lgpm	Capacity Btuh	EER Btuh/W	Capacity Btuh	COP	Capacity Btuh	EER Btuh/W	Capacity Btuh	COP	Capacity Btuh	EER Btuh/W	Capacity Btuh	COP
120	Full	28	28	109,200	13.10	147,400	4.20	115,600	19.90	122,900	3.60	113,600	15.40	93,400	2.90
	Part	28	28	60,700	14.20	75,300	4.30	62,000	20.50	62,400	3.70	62,600	18.10	56,700	3.30
180	Full	36	36	150,400	12.30	209,300	3.90	165,700	18.10	172,200	3.20	156,700	14.20	131,100	2.70
	Part	36	36	78,600	12.60	106,100	4.20	87,200	17.90	87,500	3.60	84,400	16.00	79,900	3.20

All ratings based upon 208V operation

10/14/24

Energy Star Compliance Table

Model	Tier 3	
	Ground Water	Ground Loop
120	Yes	Yes
180	No	No

12/17/10

Energy Star Rating Criteria

In order for water-source heat pumps to be Energy Star rated they must meet or exceed the minimum efficiency requirements listed below.

Tier 3: 1/1/2012 - No Effective End Date Published

	EER	COP
Closed loop water-to-air	17.1	3.6
Open loop water-to-air	21.1	4.1
Closed loop water-to-water	16.1	3.1
Open loop water-to-water	20.1	3.5

Physical Data

Model	120	180
Compressor (2 each)		
Factory Charge R-454B, oz [kg]	40 [1.13]	46 [1.30]
<i>Load Water Connection</i>		
FPT - in	2	2
<i>Source Water Connection</i>		
FPT - in	2	2
Weight - Operating, lb [kg]	400 [181]	420 [190]
Weight - Packaged, lb [kg]	395 [179]	415 [188]

Dimensional Data

120-180 - Top Waterline Configuration

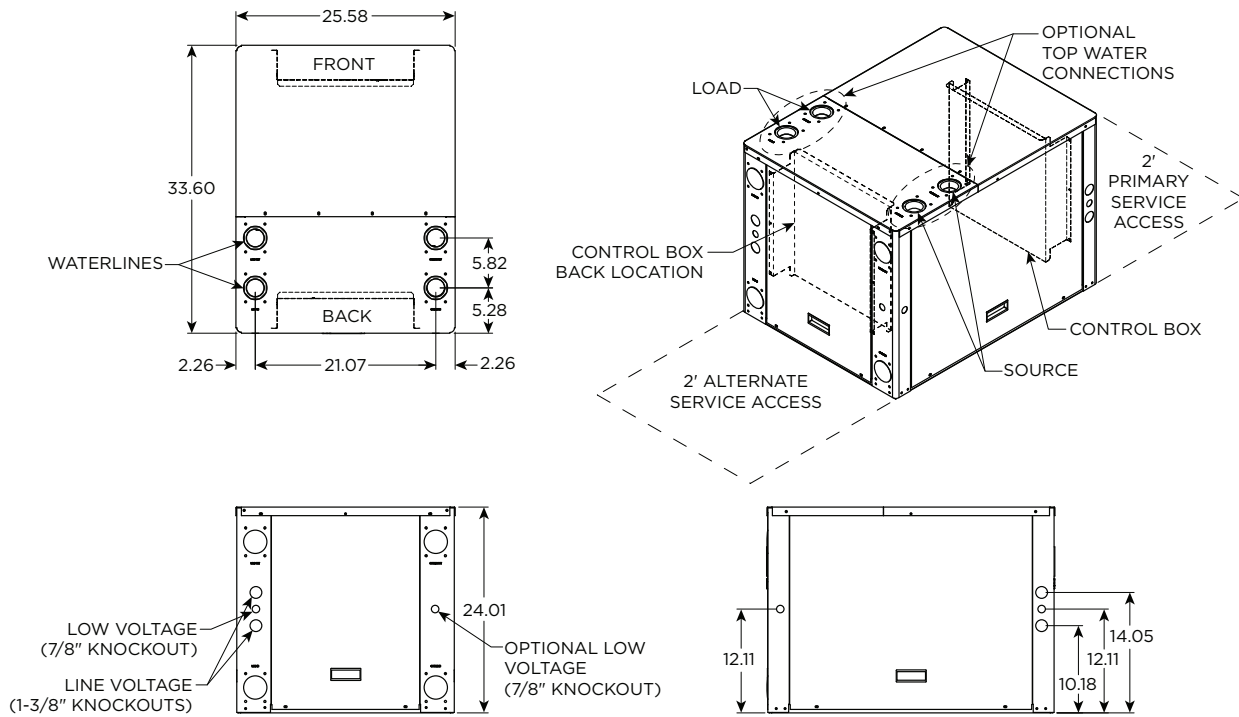

120-180 - Back Waterline Configuration

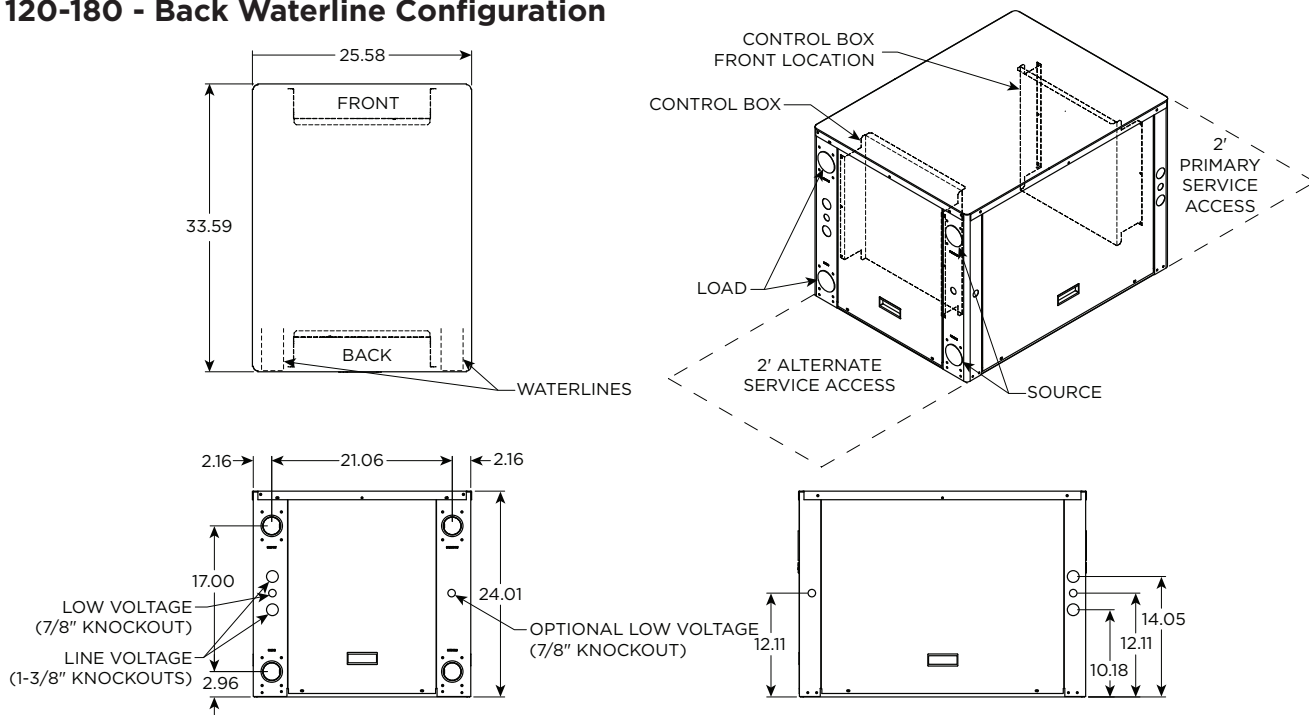

Two-Stage Hydronic Typical Application Piping

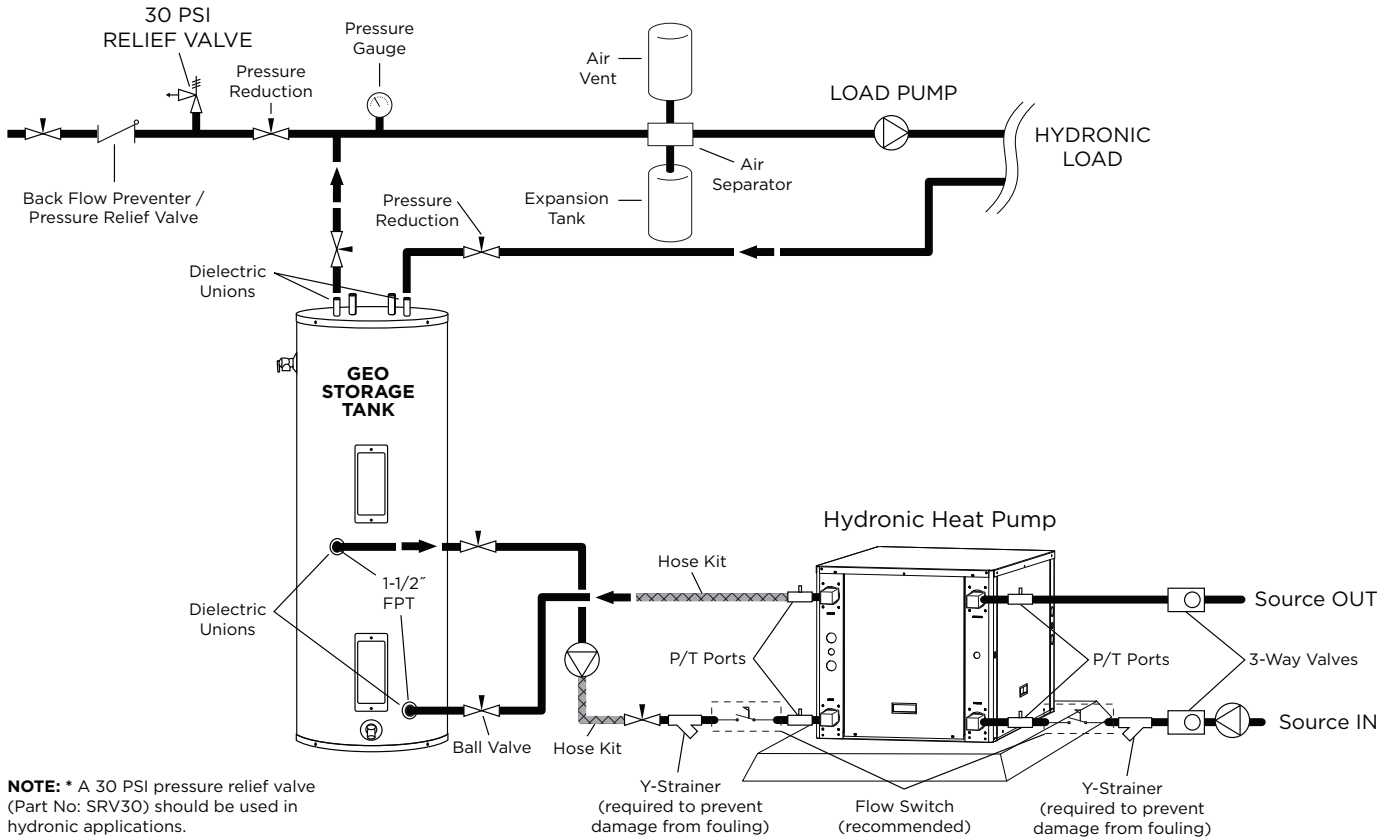

NOTE:

Due to compressor reliability direct to load application are not recommended. A buffer tank must be installed in they system.

Electrical Data

Model	Supply Circuit	Rated Voltage	Voltage Min/Max	Compressor*				Load Pump FLA	Source Pump FLA	Total Unit FLA	Min Circ Amp	Max Fuse/HACR
				MCC	RLA	LRA	LRA**					
120	L1/L2	208-230/60/1	187/253	47.0	30.1	170.0	59.5	4.2	4.2	30.1	37.6	70
	L3/L4	208-230/60/1	187/253	47.0	30.1	170.0	59.5			38.5	46.0	80
180	L1/L2	208-230/60/1	187/253	50.0	32.1	185.0	65.0	4.2	4.2	32.1	40.1	70
	L3/L4	208-230/60/1	187/253	50.0	32.1	185.0	65.0			40.5	48.5	80

HACR circuit breaker in USA only

* - Ratings per each compressor - unit supplied with two

** - With optional IntelliStart

Figure 1 - Control Box

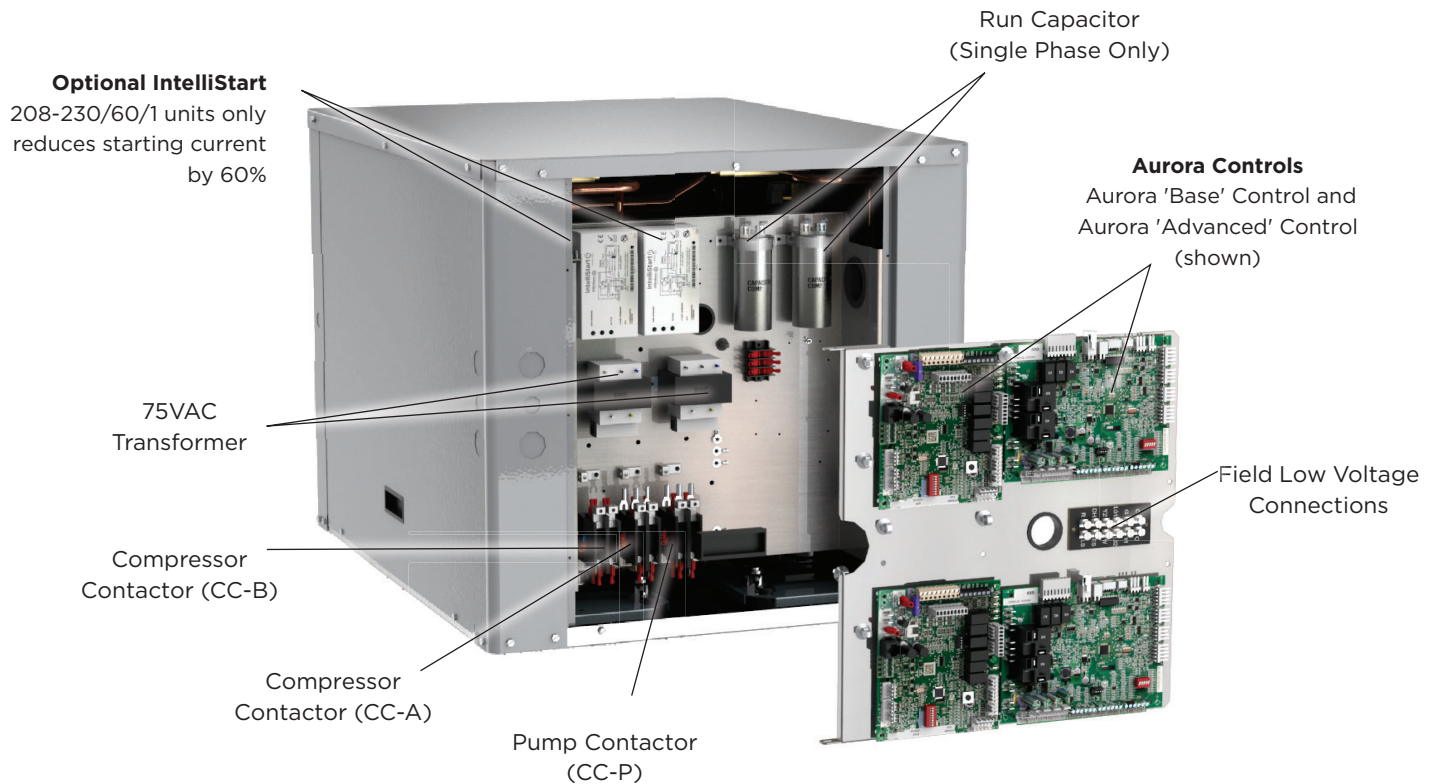

Electrical Information

WARNING

During repairs to sealed components, all electrical supplies shall be disconnected from the equipment being worked upon prior to any removal of sealed covers, etc. If it is absolutely necessary to have an electrical supply to equipment during servicing, then a permanently operating form of leak detection shall be located at the most critical point to warn of a potentially hazardous situation.

Sealed electrical components shall be replaced.

WARNING

Do not apply any permanent inductive or capacitance loads to the circuit with out ensuring that this will not exceed the permissible voltage and current permitted for the equipment in use.

Intrinsically safe components must be replaced.

Replace components only with parts specified by the manufacturer. Other parts may result in the ignition of refrigerant in the atmosphere from a leak.

NOTE The use of silicon sealant can inhibit the effectiveness of some types of leak detection equipment. Intrinsically safe components do not have to be isolated prior to working on them.

Antifreeze Corrections

Catalog performance can be corrected for antifreeze use. Please use the following table and note the example given.

Antifreeze Type	Antifreeze % by wt	Heating		Cooling		Pressure Drop
		Load	Source	Load	Source	
EWT - °F [°C]		80 [26.7]	30 [-1.1]	50 [10.0]	90 [32.2]	30 [-1.1]
Water	0	1.000	1.000	1.000	1.000	1.000
Ethylene Glycol	10	0.990	0.973	0.976	0.991	1.075
	20	0.978	0.943	0.947	0.979	1.163
	30	0.964	0.917	0.921	0.965	1.225
	40	0.953	0.890	0.897	0.955	1.324
	50	0.942	0.865	0.872	0.943	1.419
Propylene Glycol	10	0.981	0.958	0.959	0.981	1.130
	20	0.967	0.913	0.921	0.969	1.270
	30	0.946	0.854	0.869	0.950	1.433
	40	0.932	0.813	0.834	0.937	1.614
	50	0.915	0.770	0.796	0.922	1.816
Ethanol	10	0.986	0.927	0.945	0.991	1.242
	20	0.967	0.887	0.906	0.972	1.343
	30	0.944	0.856	0.869	0.947	1.383
	40	0.926	0.815	0.830	0.930	1.523
	50	0.907	0.779	0.795	0.911	1.639
Methanol	10	0.985	0.957	0.962	0.986	1.127
	20	0.969	0.924	0.929	0.970	1.197
	30	0.950	0.895	0.897	0.951	1.235
	40	0.935	0.863	0.866	0.936	1.323
	50	0.919	0.833	0.836	0.920	1.399

 **WARNING: Gray area represents antifreeze concentrations greater than 35% by weight and should be avoided due to the extreme performance penalty they represent.**

Antifreeze Correction Example

Antifreeze solution is propylene glycol 20% by weight for the source and methanol 10% for the load. Determine the corrected heating at 30°F source and 80°F load as well as pressure drop at 30°F for a Hydronic 120. Also, determine the corrected cooling at 90°F source and 50°F load.

The corrected heating capacity at 30°F/80°F would be:
 $98,500 \text{ MBTUH} \times 0.913 \times 0.985 = 88,582 \text{ MBTUH}$

The corrected cooling capacity at 90°F/50°F would be:
 $113,200 \times 0.969 \times 0.962 = 105,523 \text{ MBTUH}$

The corrected pressure drop at 30°F and 36 GPM would be:
 $4.9 \text{ psi} \times 1.270 = 6.22 \text{ psi}$

Heat of Extraction/Heat of Rejection

Model	Source GPM	Load GPM	EST °F	Heat Of Extraction (HE)				Heat of Rejection (HR)			
				60°F	80°F	100°F	120°F	50°F	70°F	90°F	110°F
120	36	36	30	91.3	81.9	72.4	63.0	154.3	172.5	190.7	208.9
			50	115.9	106.5	97.0	87.6	151.6	169.9	188.2	206.5
			70	140.5	131.1	121.6	122.2	148.9	167.3	185.7	
			90	163.1	154.5			146.7	165.1	183.4	
			110					144.5	162.8		
180	48	48	30	122.3	106.1	90.0	73.8	200.8	243.3	285.7	328.2
			50	153.4	135.3	117.3	99.2	192.0	231.7	271.5	311.3
			70	184.4	164.5	144.5	124.6	183.1	22.0	257.3	
			90	218.6	198.7			178.5	211.5	244.5	
			110					173.9	202.8		

10/14/24

Water Quality

General

Two-Stage Hydronic systems may be successfully applied in a wide range of residential, commercial, and industrial applications. It is the responsibility of the system designer and installing contractor to ensure that acceptable water quality is present and that all applicable codes have been met in these installations.

Water Treatment

Do not use untreated or improperly treated water. Equipment damage may occur. The use of improperly treated or untreated water in this equipment may result in scaling, erosion, corrosion, algae or slime. The services of a qualified water treatment specialist should be engaged to determine what treatment, if any, is required. The product warranty specifically excludes liability for corrosion, erosion or deterioration of equipment.

The heat exchangers in the units are 316 stainless steel plates with copper brazing. The water piping in the heat exchanger is steel. There may be other materials in the building's piping system that the designer may need to take into consideration when deciding the parameters of the water quality.

If an antifreeze or water treatment solution is to be used, the designer should confirm it does not have a detrimental effect on the materials in the system.

Contaminated Water

In applications where the water quality cannot be held to prescribed limits, the use of a secondary or intermediate heat exchanger is recommended to separate the unit from the contaminated water.

The following table outlines the water quality guidelines for unit heat exchangers. If these conditions are exceeded, a secondary heat exchanger is required. Failure to supply a secondary heat exchanger where needed will result in a warranty exclusion for primary heat exchanger corrosion or failure.

Strainers

These units must have properly sized strainers upstream of both brazed plate heat exchangers to protect them against particles in the fluid. Failure to install proper strainers and perform regular service can result in serious damage to the unit, and cause degraded performance, reduced operating life and failed compressors. Improper installation of the unit (which includes not having proper strainers to protect the heat exchangers) can also result in voiding the warranty.

Field supplied strainers with 20-40 mesh (530-1060 microns) are recommended, with 30 mesh (800 microns) being the optimum choice. The strainers selected should have a mesh open area of at least 6 square inches (39 square centimeters) for each unit being serviced by the strainer. Using strainers with a smaller amount of open area will result in the need for more frequent cleaning.

Strainers should be selected on the basis of acceptable pressure drop, and not on pipe diameter. The strainers selected should have a pressure drop at the nominal flow rate of the units low enough to be within the pumping capacity of the pump being used.



WARNING: Must have intermediate heat exchanger when used in pool applications.

Water Quality Guidelines

Material		Copper	90/10 Cupronickel	316 Stainless Steel
pH	Acidity/Alkalinity	7 - 9	7 - 9	7 - 9
Scaling	Calcium and Magnesium Carbonate	(Total Hardness) less than 350 ppm	(Total Hardness) less than 350 ppm	(Total Hardness) less than 350 ppm
Corrosion	Hydrogen Sulfide	Less than 0.5 ppm (rotten egg smell appears at 0.5 ppm)	10 - 50 ppm	Less than 1 ppm
	Sulfates	Less than 125 ppm	Less than 125 ppm	Less than 200 ppm
	Chlorine	Less than 0.5 ppm	Less than 0.5 ppm	Less than 0.5 ppm
	Chlorides	Less than 20 ppm	Less than 125 ppm	Less than 300 ppm
	Carbon Dioxide	Less than 50 ppm	10 - 50 ppm	10 - 50 ppm
	Ammonia	Less than 2 ppm	Less than 2 ppm	Less than 20 ppm
	Ammonia Chloride	Less than 0.5 ppm	Less than 0.5 ppm	Less than 0.5 ppm
	Ammonia Nitrate	Less than 0.5 ppm	Less than 0.5 ppm	Less than 0.5 ppm
	Ammonia Hydroxide	Less than 0.5 ppm	Less than 0.5 ppm	Less than 0.5 ppm
	Ammonia Sulfate	Less than 0.5 ppm	Less than 0.5 ppm	Less than 0.5 ppm
	Total Dissolved Solids (TDS)	Less than 1000 ppm	1000 - 1500 ppm	1000 - 1500 ppm
	LSI Index	+0.5 to -0.5	+0.5 to -0.5	+0.5 to -0.5
Iron Fouling (Biological Growth)	Iron, FE ²⁺ (Ferrous) Bacterial Iron Potential	< 0.2 ppm	< 0.2 ppm	< 0.2 ppm
	Iron Oxide	Less than 1 ppm, above this level deposition will occur	Less than 1 ppm, above this level deposition will occur	Less than 1 ppm, above this level deposition will occur
Erosion	Suspended Solids	Less than 10 ppm and filtered for max. of 600 micron size	Less than 10 ppm and filtered for max. of 600 micron size	Less than 10 ppm and filtered for max. of 600 micron size
	Threshold Velocity (Fresh Water)	< 6 ft/sec	< 6 ft/sec	< 6 ft/sec

NOTES: Grains = ppm divided by 17
mg/L is equivalent to ppm

2/22/12

Operating Parameters

Heating Mode

Entering Load Temp (°F)	Entering Source Temp (°F)	Suction Pressure (psig)	Discharge Pressure (psig)	Superheat (°F)	Subcooling (°F)
60	30	75-100	200-215	10-12	10-13
	50	100-125	200-215	12-14	8-12
	70	125-150	215-230	14-18	8-12
	90	150-165	230-255	25-30	8-12
80	30	75-100	285-300	10-12	10-13
	50	100-125	300-315	12-14	8-12
	70	125-150	315-330	14-18	8-12
	90	150-165	330-345	25-30	8-12
100	30	85-110	365-380	10-12	7-11
	50	110-135	385-400	12-14	7-11
	70	135-165	400-415	14-18	3-7
120	50	110-135	485-500	12-14	7-11
	70	135-165	500-515	14-18	3-7

10/14/24

Note: Operating data based on normal conditions with 3 gpm/ton for the load and source.

Cooling Mode

Entering Load Temp (°F)	Entering Source Temp (°F)	Suction Pressure (psig)	Discharge Pressure (psig)	Superheat (°F)	Subcooling (°F)
50	30	80-90	140-175	15-20	3-6
	50	90-100	200-235	11-15	6-9
	70	100-110	250-285	11-15	9-12
	90	100-120	330-365	8-12	12-14
	110	110-130	430-465	8-12	14-19
70	30	80-90	150-185	15-20	3-6
	50	90-100	210-245	11-15	6-9
	70	100-110	260-295	11-15	9-12
	90	110-120	340-375	8-12	12-14
	110	110-140	440-485	8-12	14-19
90	30	80-90	150-185	15-20	3-6
	50	90-100	210-245	11-15	6-9
	70	100-110	260-295	11-15	9-12
	90	110-120	340-375	8-12	12-14
110	30	90-100	160-195	40-45	3-6
	50	110-130	220-255	30-40	6-9

10/14/24

Note: Operating data based on normal conditions with 3 gpm/ton for the load and source.

Pressure Drop

Model	GPM	Pressure Drop (psi)				
		30°F	50°F	70°F	90°F	110°F
120	18	1.6	1.3	1.1	0.8	0.6
	28	3.4	3.2	2.9	2.7	2.1
	36	4.9	4.7	4.4	4.2	3.3
	40	5.6	5.4	5.1	4.9	3.9
180	24	2.7	2.4	2.2	1.9	1.5
	36	4.9	4.7	4.4	4.2	3.3
	48	7.1	6.9	6.6	6.4	5.1
	60	9.3	9.1	8.8	8.6	7.0

3/9/09

Flow Rate

Load Flow Rate

The load flow on all water to water products including the Two-Stage Hydronic Series should be 3 gpm per ton (typically the rated flow and the highest flow shown in the capacity charts). Refer to the table below. This flow rate is required especially when heating water to limit the effects of the higher condensing temperatures of water heating for radiant floor heating or domestic water use.

	Source Flow Rate			Load Flow Rate
	Minimum Open Loop	Open Loop < 50°F	Closed Loop Range (Min - Full Flow)	
120	18	24	27 36	36
180	24	32	36 48	48

Source Flow Rate

The source flow can range between 2.25 and 3 gpm per ton for earth loops. For open loop well water systems the minimum flow should be 1.5 gpm per ton. In earth loop systems where entering water temperatures are expected to be above 95°F, 3 gpm per ton should be used. In well systems where the water temperature is below 50°F, 2 gpm per ton should be used to avoid nuisance freeze detection trips.

Aurora Control System

Aurora 'Base' Control

The Aurora 'Base' Control (ABC) System is a complete residential and commercial comfort system that brings all aspects of the HVAC system into one cohesive module network. The ABC features microprocessor control and HP, LP, condensate and freeze detection, over/under voltage faults, along with communicating thermostat capability for complete fault detection text at the thermostat.

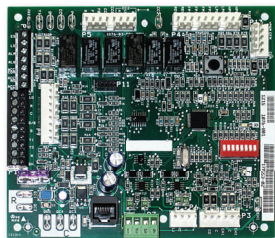

Aurora uses the Modbus communication protocol to communicate between modules. Each module contains the logic to control all features that are connected to the module. The Aurora 'Base' Control (ABC) has two Modbus channels. The first channel is configured as a master for connecting to devices such as a communicating thermostat, expansion board, or other slave devices. The second channel is configured as a slave for connecting the Aurora Interface Diagnostics Tool (AID Tool).

Aurora 'Advanced' Control

The Aurora 'Advanced' Control expands on the capability of the Aurora 'Base' Control (ABC) System by adding the Aurora Expansion Board (AXB). The additional features include compressor current monitoring, loop pump linking, intelligent hot water generator control, variable speed pump capability, and also allows for optional energy, refrigeration, and performance monitoring factory installed add-on sensor kits. The AXB also features a second field configurable accessory relay, and two home automation inputs that are AID configurable for different types of alarms from sump pumps to home security. The Smart Grid input is AID configurable with many options to react to Utility controlled relay operation for ON Peak optimization.

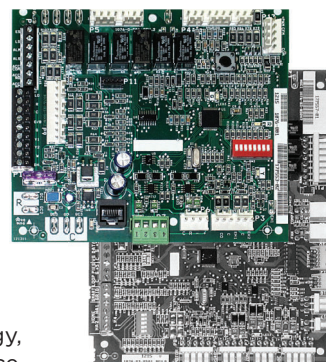

Aurora Control Features	Description	Aurora 'Base'	Aurora 'Advanced'
Microprocessor Compressor Control	Microprocessor control of compressor for timings with FP1, HP, LP, Condensate, assignable Acc relay	•	•
Advanced Microprocessor Features	Smart Grid, Home Automation Alarm Inputs, and Accessory2 Relay (HRV/ERV)	-	•
Base Loop Pump Control	Compressor Contactor powers Loop Pump and no loop pump linking capability.	•	See below
Compressor Monitoring	Control monitors compressor starts for high current, missing leg etc.	-	•
Smart Grid/Utility Input	Allows simple input to externally enable of occupied/unoccupied mode for basic utility time of use programs.	-	Dry Contact x1

Aurora Control System

Service Device	Description	Aurora 'Base'	Aurora 'Advanced'
 <p>Aurora Interface and Diagnostics (AID) Tool</p>	<p>Allows setup, monitoring and troubleshooting of any Aurora Control.</p> <p>NOTE: Although the ABC has basic compatibility with all Aurora, new product features may not be available on older AID Tools. To simplify the basic compatibility ensure the version of AID is at least the same or greater than the ABC software version.</p>	For Service go to Aurora Toolbox for latest firmware version	For Service go to Aurora Toolbox for latest firmware version

Add On Control Feature Kits (factory installed)	Description	Aurora 'Base'	Aurora 'Advanced'
Geo Energy Monitoring Kit	Monitors realtime power consumption of compressor, aux heat and pump. AXB required.	-	Standard
Refrigeration Monitoring Kit	Monitors realtime pressures, temperatures, superheat, and subcooling. AXB required.	-	Standard
Performance Monitoring Kit	Monitors water temperatures	-	Standard
Data Logging (AWL) Kit	Allows data logging of up to 12 months. Can also be temporarily installed for troubleshooting.	-	Optional

Add On Thermostats and Zoning	Description	Aurora 'Base'	Aurora 'Advanced'
HZO	Non-communicating controller for up to two heat pumps.	Standard	Standard

Aurora Control System

Aurora 'Base' Control

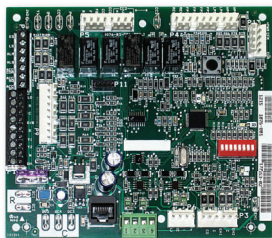

NOTE: Refer to the Aurora Base Control Application and Troubleshooting Guide and the Instruction Guide: Aurora Interface and Diagnostics (AID) Tool for additional information.

Control Features

- Random start at power up
- Anti-short cycle protection
- High and low pressure cutouts
- Loss of charge
- Water coil freeze detection
- Over/under voltage protection
- Load shed
- Emergency shutdown
- Diagnostic LED
- Test mode push button switch
- Alarm output
- Accessory output with N.O. and N.C.
- Modbus communication

Field Selectable Options via Hardware

DIP Switch (SW1) - Test/Configuration Button (See SW1 Operation Table)

Test Mode

The control is placed in the test mode by holding the push button switch SW1 for 2 - 5 seconds. In test mode most of the control timings will be shortened by a factor of sixteen (16). LED3 (green) will flash at 1 second on and 1 second off. Additionally, when entering test mode LED1 (red) will flash the last lockout one time. Test mode will automatically time out after 30 minutes. Test mode can be exited by pressing and holding the SW1 button for 2 to 5 seconds or by cycling the power. **NOTE:** Test mode will automatically be exited after 30 minutes.

Reset Configuration Mode

The control is placed in reset configuration mode by holding the push button switch SW1 for 50 to 60 seconds. This will reset all configuration settings and the EEPROM back to the factory default settings. LED3 (green) will turn off when entering reset configuration mode. Once LED3 (green) turns off, release SW1 and the control will reset.

DIP Switch (SW2)

SW2-1 (Source) FP1 Selection - Low water coil temperature limit setting for freeze detection. On = 30°F; Off = 15°F.

SW2-2 (Load) FP2 Selection - On = 30°F; Off = 15°F

SW2-3 RV - O/B - thermostat type. Heat pump thermostats with "O" output in cooling or "B" output in Heating can be selected. On = O; Off = B.

SW2-4 Access Relay Operation (P2)

and 2-5

Access Relay Operation	SW2-4	SW2-5
Cycle with Blower		n/a
Cycle with Compressor	OFF	OFF
Water Valve Slow Opening	ON	OFF
Cycle with Comm. T-stat Hum Cmd		n/a

Cycle with Blower - (Not used on water-to-water)

Cycle with Compressor - The accessory relay will cycle with the compressor output.

Water Valve Slow Opening - The accessory relay will cycle and delay both the blower and compressor output for 90 seconds.

SW2-6 CC Operation - selection of single or dual capacity compressor. On = Single Stage; Off = Dual Capacity

SW2-7 Lockout and Alarm Outputs (P2) - selection of a continuous or pulsed output for both the LO and ALM Outputs. On = Continuous; Off = Pulsed

SW2-8 *Future Use*

Alarm Jumper Clip Selection

From the factory, ALM is connected to 24 VAC via JW2. By cutting JW2, ALM becomes a dry contact connected to ALG.

Field Selectable Options via Software

(Selectable via the Aurora AID Tool)

Safety Features

The following safety features are provided to protect the compressor, heat exchangers, wiring and other components from damage caused by operation outside of design conditions.

Fuse - a 3 amp automotive type plug-in fuse provides protection against short circuit or overload conditions.

Anti-Short Cycle Protection - 4 minute anti-short cycle protection for the compressor.

Random Start - 5 to 80 second random start upon power up.

Aurora Control System

Fault Retry - in the fault condition, the control will stage off the outputs and then “try again” to satisfy the thermostat Y input call. Once the thermostat input calls are satisfied, the control will continue on as if no fault occurred. If 3 consecutive faults occur without satisfying the thermostat Y input call, then the control will go to Lockout mode.

Lockout - The Alarm output (ALM) and Lockout output (L) will be turned on. The fault type identification display LED1 (Red) shall flash the fault code. To reset lockout conditions with SW2-8 On, thermostat inputs “Y1”, “Y2”, and “W” must be removed for at least 3 seconds. To reset lockout conditions with SW2-8 Off, thermostat inputs “Y1”, “Y2”, “W”, and “DH” must be removed for at least 3 seconds. Lockout may also be reset by turning power off for at least 30 seconds or by enabling the emergency shutdown input for at least 3 seconds.

High Pressure - fault is recognized when the Normally Closed High Pressure Switch, P4-9/10 opens, no matter how momentarily. The High Pressure Switch is electrically in series with the Compressor Contactor and serves as a hard-wired limit switch if an overpressure condition should occur.

Low Pressure - fault is recognized when the Normally Closed Low Pressure Switch, P4-7/8 is continuously open for 30 seconds. Closure of the LPS any time during the 30 second recognition time restarts the 30 second continuous open requirement. A continuously open LPS shall not be recognized during the 2 minute startup bypass time.

Loss of Charge - fault is recognized when the Normally Closed Low Pressure Switch, P4-7/8 is open prior to the compressor starting.

Freeze Detection (Source Coax) - set points shall be either 30°F or 15°F. When the thermistor temperature drops below the selected set point, the control shall begin counting down the 30 seconds delay. If the thermistor value rises above the selected set point, then the count should reset. The resistance value must remain below the selected set point for the entire length of the appropriate delay to be recognized as a fault. This fault will be ignored for the initial 2 minutes of the compressor run time.

Freeze Detection (Load Coax) - uses the FP2 input to protect against ice formation on the coax. The FP2 input will operate exactly like FP1.

Over/Under Voltage Shutdown - An over/under voltage condition exists when the control voltage is outside the range of 18 VAC to 30 VAC. If the over/under voltage shutdown lasts for 15 minutes, the lockout and alarm relay will be energized. Over/under voltage shutdown is self-resetting in that if the voltage comes back within range of 18 VAC to 30 VAC for at least 0.5 seconds, then normal operation is restored.

Operation Description

Power Up - The unit will not operate until all the inputs and safety controls are checked for normal conditions. The unit has a 5 to 80 second random start delay at power up. Then the compressor has a 4 minute anti-short cycle delay after the random start delay.

Standby In standby mode, Y1, Y2, W, DH, and G are not active. Input O may be active. The compressor will be off.

Heating Operation

Heating, 1st Stage (Y1) - The compressor is energized 10 seconds after the Y1 input is received.

Cooling Operation

In all cooling operations, the reversing valve directly tracks the O input. Thus, anytime the O input is present, the reversing valve will be energized.

Cooling, 1st Stage (Y1, O) - The compressor is energized 10 seconds after the Y1 input is received.

Emergency Shutdown - Four (4) seconds after a valid ES input, P2-7 is present, all control outputs will be turned off and remain off until the emergency shutdown input is no longer present. The first time that the compressor is started after the control exits the emergency shutdown mode, there will be an anti-short cycle delay followed by a random start delay. Input must be tied to common to activate.

Load Shed - The LS input disables all outputs with the exception of the blower output. When the LS input has been cleared, the anti-short cycle timer and random start timer will be initiated. Input must be tied to common to activate.

Aurora Control System

Aurora 'Base' Control LED Displays

These three LEDs display the status, configuration, and fault codes for the control. These can also be read in plain English via the Aurora AID Tool.

Status LED (LED3, Green)

Description of Operation	Fault LED, Green
Normal Mode	ON
Control is Non-functional	OFF
Test Mode	Slow Flash
Lockout Active	Fast Flash
Dehumidification Mode	Flash Code 2
(Future Use)	Flash Code 3
(Future Use)	Flash Code 4
Load Shed	Flash Code 5
ESD	Flash Code 6
(Future Use)	Flash Code 7

Fault LED (LED1, Red)

Red Fault LED	LED Flash Code*	Lockout	Reset/Remove
Normal - No Faults	OFF	-	
Fault - Input	1	No	Auto
Fault - High Pressure	2	Yes	Hard or Soft
Fault - Low Pressure	3	Yes	Hard or Soft
Fault - Freeze Detection FP2	4	Yes	Hard or Soft
Fault - Freeze Detection FP1	5	Yes	Hard or Soft
Fault - Condensate Overflow	7	Yes	Hard or Soft
Fault - Over/Under Voltage	8	No	Auto
Fault - FP1 & FP2 Sensor Error	11	Yes	Hard or Soft

NOTE: All codes >11 use long flash for tens digit and short flash for the ones digit. 20, 30, 40, 50, etc. are skipped.

Aurora Interface and Diagnostics (AID) Tool

The Aurora Interface and Diagnostics (AID) Tool is a device that is a member of the Aurora network. The AID Tool is used to troubleshoot equipment which uses the Aurora control via Modbus RTU communication. The AID Tool provides diagnostics, fault management, ECM setup, and system configuration capabilities to the Aurora family of controls. An AID Tool is recommended, although not required, for ECM airflow settings. The AID Tool simply plugs into the exterior of the cabinet in the AID Tool port.



ABC Control Board Layout

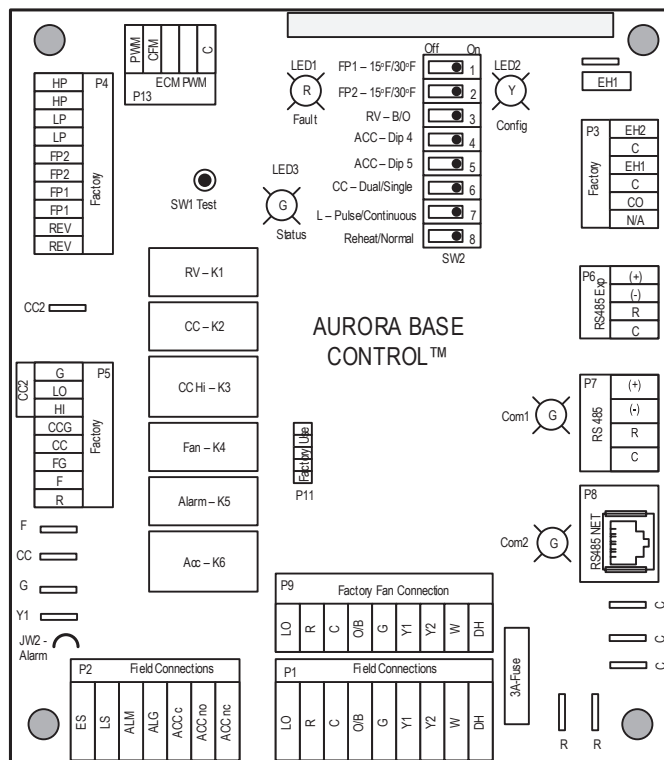

Aurora Control System

Aurora ‘Advanced’ Control Features

The Aurora ‘Advanced’ Control system expands on the capability of the Aurora ‘Base’ Control (ABC) by adding the Aurora Expansion Board (AXB). All of the preceding features of the Aurora ‘Base’ Control are included. The following control description is of the additional features and capability of the Aurora advanced control.

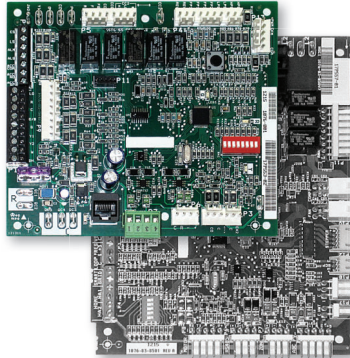

It is highly recommended the installing/servicing contractor obtain an Aurora Interface and Diagnostic Tool (AID) and specialized training before attempting to install or service an Aurora ‘Advanced’ control system.



The additional AXB features include the following:

AXB DIP Switch

DIP 1 - ID: This is the AXB ModBus ID and should always read On.

DIP 2 & 3 - Future Use

DIP 4 & 5 - Accessory Relay2: A second, DIP configurable, accessory relay is provided that can be cycled with the compressor 1 or 2, blower, or the Dehumidifier (DH) input. This is to complement the Accessory 1 Relay on the ABC board.

Position	DIP 4	DIP 5	Description
1	ON	ON	Cycles with Fan or ECM (or G)
2	OFF	ON	Cycles with CC1 first stage of compressor or compressor spd 6
3	ON	OFF	Cycles with CC2 second stage of compressor or compressor spd 7-12
4	OFF	OFF	Cycles with DH input from ABC board

Compressor Monitoring

The AXB includes two current transducers to monitor the compressor current and starting characteristics. Open circuits or welded contactor faults will be detected. A fault will produce an E10 code.

Advanced Communication Ports

Communication ports P6 and P8 will provide future expansion via dedicated protocols. These are for future use.

Aurora Control System

Smart Grid-On Peak (SG) Input

The 'On Peak' input was designed to allow utilities to utilize simple radio controlled switches to control the On Electric Peak behavior of the 5 and 7 Series Geothermal Heat Pumps. With a closed contact signal, this input will limit the operation and thus the power consumption of the unit by one of the below selections. The AID Tool will allow configuration of this input for the action of:

- No Action
- Disable compressor operation until removed
- Go to On Peak thermostat settings until removed [Requires Com T-Stat] (Future Release)
- Compressor limited to 50% or low cap until removed [dual capacity or variable speed only] (Future Release)
- Disable compressor operation for 1/2 hr (can be removed immediately) (Future Release)

Then Flash Code 7 on the Green LED for the 'On Peak' mode. And On Peak will display on communicating thermostats.

Monitoring Sensor Kits

Energy Monitoring (Standard Sensor Kit)

The Energy Monitoring Kit includes four current transducers (source pump, load pump, auxiliary heat 1 and auxiliary heat 2) added to the existing four compressor sensors for compressor A and compressor B so that the complete power usage of the heat pump can be measured. The AID Tool provides a line voltage calibration procedure to improve the accuracy, and a power adjustment setting that allows the compressor power to be adjusted to match the units line voltage using the provided tables. This information can be displayed on the AID Tool.

Refrigerant Monitoring

The Refrigerant Monitoring Kit includes two pressure transducers, and three temperature sensors, heating liquid line, suction temperature and existing cooling liquid line (FP1). These sensors allow the measurement of discharge and suction pressures, suction and liquid line temperatures as well as superheat and subcooling. This information will only be displayed on the AID Tool.

Performance Monitoring

The Performance Monitoring Kit includes three temperature sensors, entering and leaving source, and leaving load water.

Aurora Control System

Aurora 'Advanced' Control LED Displays

These three LEDs display the status, configuration, and fault codes for the control. These can also be read in plain English via the Aurora AID Tool.

Status LED (LED3, Green)

Description of Operation	Fault LED, Green
Normal Mode	ON
Control is Non-functional	OFF
Test Mode	Slow Flash
Lockout Active	Fast Flash
Dehumidification Mode	Flash Code 2
Load Shed	Flash Code 5
Emergency Shutdown	Flash Code 6
On Peak Mode	Flash Code 7
(Future Use)	Flash Code 8
(Future Use)	Flash Code 9

Configuration LED (LED2, Yellow)

Description of Operation	Configuration LED, Yellow
No Software Overwritten	ECM Setting
DIP Switch Overwritten	Slow Flash
ECM Configuration Mode	Fast Flash
Reset Configuration Mode	OFF

Fault LED (LED1, Red)

Red Fault LED	LED Flash Code *	Lockout	Reset/Remove	Fault Condition Summary	
Normal - No Faults	Off	-			
ABC Basic Faults	Fault-Input	1	No	Auto	Tstat input error. Autoreset upon condition removal.
	Fault-High Pressure	2	Yes	Hard or Soft	HP switch has tripped (>600 psi)
	Fault-Low Pressure	3	Yes	Hard or Soft	Low Pressure Switch has tripped (<40 psi for 30 continuous sec.)
	Fault-Freeze Detection FP2	4	Yes	Hard or Soft	Freeze protection sensor has tripped (<15 or 30 degF for 30 continuous sec.)
	Fault-Freeze Detection FP1	5	Yes	Hard or Soft	Freeze protection sensor has tripped (<15 or 30 degF for 30 continuous sec.)
	Fault-Condensate Overflow	7	Yes	Hard or Soft	Condensate switch has shown continuity for 30 continuous sec.
	Fault-Over/Under Voltage	8	No	Auto	Instantaneous voltage is out of range. **Controls shut down until resolved.
	Fault-FP1 Snsr Error	11	Yes	Hard or Soft	If FP1 Sensor Error
ABC & AXB Advanced Faults	Fault-Compressor Monitor	10	Yes	Hard or Soft	Open Crkt, Run, Start or welded cont
	Non-CriticAXBSnsrErr	13	No	Auto	Any Other Sensor Error
	CriticAXBSnsrErr	14	Yes	Hard or Soft	Sensor Error for EEV or HW
	Alert-HotWtr	15	No	Auto	HW over limit or logic lockout. HW pump deactivated.
	Fault-VarSpdPump	16	No	Auto	Alert is read from PWM feedback.
	Not Used	17	No	Auto	I22 Com Fault. Autoreset upon condition removal.
	Non-CritComErr	18	No	Auto	Any non-critical com error
	Fault-CritComErr	19	No	Auto	Any critical com error. Auto reset upon condition removal
	Alarm - Low Loop Pressure	21	No	Auto	Loop pressure is below 3 psi for more than 3 minutes
	Alarm - Home Automation 1	23	No	Auto	Closed contact input is present on Dig 2 input - Text is configurable
Alarm - Home Automation 2	24	No	Auto	Closed contact input is present on Dig 3 input - Text is configurable	

NOTES:

*All codes >11 use long flash for tens digit and short flash for the ones digit. 20, 30, 40, 50 etc. are skipped!

Alert' is a noncritical sensor or function that has failed. Normal operation of the heat pump is maintained but service is desired at some point.

Aurora Control System

Aurora now expands the Fault/Alarms in to several groups. Faults are system critical faults to the heat pump and will cause a Lockout. Some are retried 3 times before locking out while others lockout out immediately. Consult the Fault Retries table before lockout for details. Alarms are designed solely to alert the customer and the dealer to alarms designed as an input only to the Aurora system. These alarms are not system critical. Errors are sensor/hardware errors that although may not be system critical, may need serviced for optimal features.

SafeMode - the system is still operational during safemode.

Summary Table of Faults, Alarm, and Errors

All lockouts and alarms are shown in the Status LED (LED1, Red) table with the associated codes visible on the thermostat, ABC Fault LED, and in text in the AID Tool.

Aurora Fault Codes (ABC-Red LED)

These fault codes generally will affect the operation of the heat pump and will cause a lockout.

E1, Fault Input - A Y1/Y2 style thermostat is providing a non-normal sequence of signals possibly caused by a bad thermostat wire or connection.

E2, High Pressure - Fault is recognized when the Normally Closed High Pressure Switch, P4-9/10 opens, no matter how momentarily. The High Pressure Switch is electrically in series with the Compressor Contactor and serves as a hardwired limit switch if an overpressure condition should occur.

E3, Low Pressure - Fault is recognized when the Normally Closed Low Pressure Switch, P4-7/8 is continuously open for 30 seconds. Closure of the LPS any time during the 30 second recognition time restarts the 30 second continuous open requirement. A continuously open LPS shall not be recognized during the 2 minute startup bypass time.

E3, Loss of Charge - Fault is recognized when the Normally Closed Low Pressure Switch, P4-7/8 is open prior to the compressor starting.

E4, Freeze Detection-Air Coil - Air Coil Freeze Detection will use the FP2 input to protect against ice formation on the air coil. The FP2 input will operate exactly like FP1 except that the set point is 30 degrees and is not field adjustable.

E5, Freeze Detection-Coax - Set points shall be either 30°F or 15°F. When the thermistor temperature drops below the selected set point, the control shall begin counting down the 30 seconds delay. If the thermistor value rises above the selected set point, then the count should reset. The resistance value must remain below the selected set point for the

entire length of the appropriate delay to be recognized as a fault. This fault will be ignored for the initial 2 minutes of the compressor run time.

E7, Condensate Overflow - Fault is recognized when the impedance between this line and 24 VAC common or chassis ground drops below 100K ohms for 30 seconds continuously.

E8, Over/Under Voltage Shutdown - An over/under voltage condition exists when the control voltage is outside the range of 18 VAC to 30 VAC. If the over/under voltage shutdown lasts for 15 minutes, the lockout and alarm relay will be energized. Over/under voltage shutdown is self-resetting in that if the voltage comes back within range of 18 VAC to 30 VAC for at least 0.5 seconds, then normal operation is restored.

E10, Compressor Monitoring - Fault is recognized when the compressor has an open circuit, potential welded contactor.

E11, FP1 Sensor Error - Fault is recognized when the impedance between this line and 24 VAC common or chassis.

E14, Critical AXB Sensor Error - Fault is recognized when a sensor faults that is critical to heat pump operation. These sensors would include the HW Temperature limit sensor.

E15, Alarm Hot Water - Fault is recognized when the hot water temperature sensor is either over the configured limit or the Aurora has determined the current conditions should disengage the hot water generation capability.

E16, Variable Speed Pump - Fault is recognized when the variable speed pump returns a fault code from its PWM feedback signal.

E19, Critical Communication Error - A critical communication error has occurred with a board that previously had been configured but now is not available for communication. Since this is critical to unit operation, the heat pump will be locked out with this fault displayed on the ABC board and the thermostat. The AID Tool should be used to view the configuration window and ascertain the status of all appropriate board communication. The fault displayed will be removed when the problem has been resolved or the unit is soft or hard reset.

E52, Suction Pressure Invalid - The reading of the suction pressure transmitter is not within the specified sensor range of 0 to 16bar (0 to 232psi). Possible causes are faulty wiring or a defective transmitter.

E81, ASB Leak Detected - The gas sensor has detected a leak. The ABS will communicate the leak to the ABC control board. Compressor and auxiliary heat will be deactivated, and blower will come on.

Aurora Control System

E82, ASB Sensor Problem - The gas sensor has lost communication with the ASB board or has an internal error.

E97, Invalid System Configuration - ABC has not been configured for sensor or refrigeration type.

Aurora Error Codes

NOTE: The system is operating normally, but a sensor or communication issue is preventing full features of the system. Since these can be deemed non-critical to system operation, such as internet access boards etc., they may simply cause errors/alerts that signal the user to the situation but may not effect normal operation.

E13, Non Critical AXB Sensor Error - Fault is recognized when a sensor faults that is not critical to heat pump operation. These sensors would include the performance, energy monitoring and refrigeration sensors.

E18, Error Non-Critical Communication Error - A non-critical communication error has occurred such as communication to the internet access board. Since this is not critical to unit operation, the heat pump will continue operating normally with this error displayed on the ABC board and the thermostat. The AID Tool should be used to view the configuration window and ascertain the status of all appropriate board communication. The Error displayed will be removed when the problem has been resolved.

Aurora SafeMode Codes

NOTE: The system is still operational during safemode. It is possible for some situations to progress from Derating to SafeMode to finally locking out due to a fault.

E72, SafeMode EEV - Suction Temperature Invalid - The reading of the suction temperature sensor is not within the specified sensor range of -60 to +200°C (-76 to +392°F). The EEV will be positioned at 50%. Possible causes are faulty wiring or a defective sensor.

E73, SafeMode EEV - Leaving Air Temperature (LAT) Invalid - The reading of the leaving air temperature sensor is not within the specified sensor range of -60 to +200°C (-76 to +392°F). Normal operation will continue with an Error 73 display on the thermostat to notify the user of the issue. Possible causes are faulty wiring or a defective sensor. The Error displayed will be removed when the problem has been resolved.

E74, SafeMode EEV - Maximum Operating Pressure (MOP)

- The reading of the suction pressure is above the recommended limit. If this condition persists more than 90 seconds, the Drive will revert to a Fault - Out of Envelope Code 35.

Aurora Alarm Codes

These alarms are planned to alert the homeowner and the service personnel but will NOT effect system operation and are for information only. These would be available on the thermostat, AID Tool and the internet access for remote monitoring capability.

E21, Loop Pressure Alarm - Fault is recognized when the loop pressure sensor is installed and the loop pressure falls below the setpoint.

E23 and E24, Home Automation 1 and 2 Inputs - The Home automation inputs are simple 24VAC inputs that will trigger an AID Tool and thermostat alert for the homeowner. These would require optional sensors and or equipment for connection to the AXB board. With two inputs, two different sensors can be selected. The selected text will then be displayed on the AID Tool and com thermostats. These events will NOT alter functionality or operation of the heat pump/accessories and is for homeowner/service notification only. With a closed dry contact signal, this input will cause an alarm E23 or E24 to indicate on the stat or flash on ABC. The AID Tool will allow configuration of these two inputs independently between the following selections:

- *No Action*
- *Home Automation Fault [no lockout, info only]* - Output from home automation system

HydroZone Controller Instructions

Installation Instructions

The HydroZone controller is a part of the hydronic heat pump system. The part number for this product is HZC. This controller is a human interface and **water tank** control device. The controller displays and regulates the water tank temperature, but not the conditioned space. A 2-1/2" x 2-1/2" LCD display and five push button keys serve as the human interface. The five keys are: the up and down keys (▲ and ▼) for changing the selection or temperature, the right and left keys (◀ and ▶) for changing the selection or mode, and the enter key (■) is for accepting and/or saving the selection.

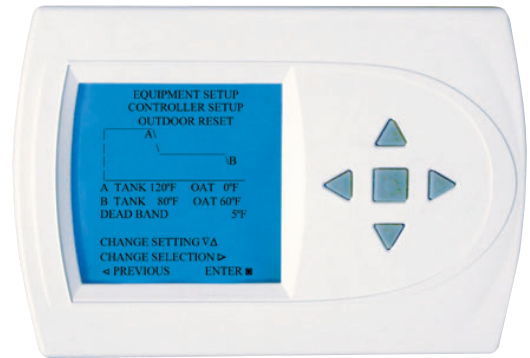

Figure 1

Controller Operation

Adjusting Temperature

1. To select a MODE, use the keypad arrows to scroll to MODE. Then, press the enter button on the key pad to enter the operating mode menu.
2. Select the desired mode by scrolling up or down, with the arrows. **Then press the enter button on the keypad to enter into that mode.**
3. You are now returned to the Main Menu and Figure 1 is a similar view. **NOTE: Outdoor air temperature is only displayed if an outdoor air sensor is installed.**
4. To increase the temperature set point, use the arrow up button. To decrease the set point, use the arrow down button. Five (5) seconds after the last button push, the new setpoint is saved. **Outdoor reset control is done in the installer's setup and cannot be adjusted from the front screen.**

Setting Date And Time

1. From the Main Menu, scroll to MENU and press the enter button ■ on the keypad.
2. Select SET DATE.
3. SET MONTH by using the up and down arrows ▲▼. Then press the enter button ■ on the keypad to save the month.
4. SET DAY by using the up and down arrows ▲▼. Then press the enter button ■ on the keypad to save the day.
5. SET YEAR by using the up and down arrows ▲▼. Then press the enter button ■ on the keypad to save the year.
6. Select SET TIME.
7. SET HOUR by using the up and down arrows ▲▼. Then press the enter ■ button on the keypad to save the hour.
8. SET MINUTE by using the up and down arrows ▲▼. Then press the enter button ■ on the keypad to save the minute.
9. If your area observes daylight savings time, select AUTO DAYLIGHT SAVING; scroll to ON, then press the enter button ■ to save. You will be returned to the SET DATE AND TIME menu. Scroll to SET DATE AND TIME and press the enter button ■ on the keypad.
10. The date and time are now set. You can return to the Main Menu by pressing the left arrow key to return to the previous menu.

Changing Modes

1. From the main screen select MODE.
2. Select the operating mode you need and press the enter button ■.
NOTE: If selecting EMERGENCY HEAT, the backlight color will change from blue to red indicating that auxiliary heat is operating instead of the heat pump compressor. Auxiliary/emergency heat is significantly more expensive to operate than the heat pump compressor, and should not be selected unless the heat pump compressor is not operational.

Fahrenheit or Celsius

1. From the Main Menu, scroll to MENU and press the enter button ■ on the keypad.
2. Select FAHRENHEIT/CELSIUS.
3. Select which scale you prefer.

HydroZone Controller Instructions

Backlight on Time

This controller has a two color backlight feature. Anytime a button is pressed, the blue backlight stays on for a certain amount of time. A red backlight is visible if you are selecting Emergency Heat mode. You can adjust the amount of time the backlight stays on in the menu options.

1. From the Main Menu, scroll to MENU and press the center button ■ on the keypad.
2. You can change the backlight on time by using the up and down arrows ▲▼. BACKLIGHTING ON (all the time), 15 sec., 30 sec., and NO BACKLIGHTING are your choices. Press the enter ■ button to save the new backlight on time.

Advanced Settings

Security Lockout

This controller has the option to set security features to lockout everything but the adjustment of the temperature or a total keypad lockout.

1. From the Main Menu, scroll to MENU and press the enter button ■ on the keypad.
2. Select LOCK/UNLOCK.
3. The selection will bring you to the Enter Pin Number screen.
4. Using the up and down arrows ▲▼, select a pin number to lock out the thermostat. The right arrow ► moves you to the next pin digit.
5. Once you've entered the 4-digit pin number, press the enter button ■ to save the pin. The screen will display LOCKED and return to the main Screen.
6. Once you return to the Main Screen, in the upper left of the screen will alternate between LOCKED and the date and time.
7. Once unlocked, you will have to reset a pin number again to lockout the thermostat again.
8. In the event the pin number is lost, the default is 9999.

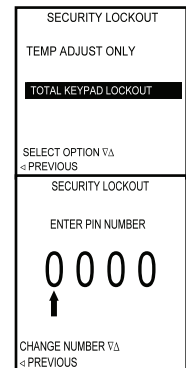

Installer Information and Advanced Features

Safety Considerations

Improper wiring or installation may damage the controller. Wiring must conform to local and national electrical codes.

Introduction

The controller is a low-voltage controller which maintains geo storage tank temperature by controlling the operation of multiple hydronic heat pumps system. Batteries are not required; temperature and mode settings are preserved with the power off. The controller is not a power stealing device and MUST have both R and C connected. This controller does not regulate temperature in the conditioned space.

HydroZone Installation

1. Turn off all power to unit.
2. Separate the front and back pieces of the HZO.
3. Mount the base of the HZO.
4. Connect wires to proper terminal on the pump relay. (see wiring schematic 97P806-01 on page .
5. Replace the cover on the base.
6. Turn on power to the unit.

NOTE: If the unit is connected to a Geo-Tank that does not have a tank water temperature sensor. Tank sensor kit GTANKTSK is shipped with the unit. This kit includes a bung fitting and well point thermistor.

HydroZone Controller Instructions

Main Screen

After exiting from the setup mode, controller displays the main screen.

OPERATION, displays the current controller setup selection. They are OUTDOOR, TANK CONTROL AUTO, and TANK CONTROL MANUAL MODE. If the operation mode is outdoor reset or tank control auto, the MODE should display OFF, ON, or EHEAT. If the operation mode is tank control manual, the MODE should display OFF, HEAT, COOL, or EMHT. OUTPUT shall display the current status of the outputs (WARM WEATHER SHUTDOWN, STANDBY, C1, C2, C3, C4, or AUX). STANDBY mode is active when the controller is satisfied and waiting for a call. C1, C2, C3, and C4 will be off and O will stay in its previous state. If the outputs are off due to a warm weather shutdown condition, the proper message should be displayed.

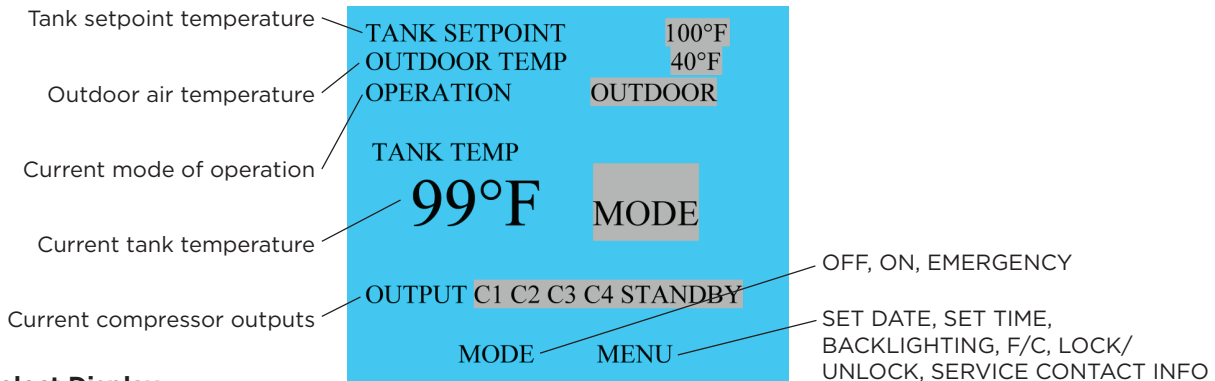

Mode Select Display

Manual Tank Control Display

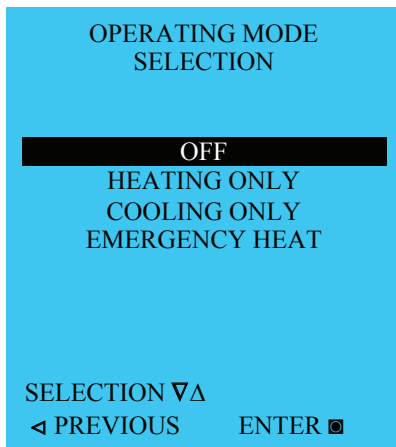

Outdoor Reset or Tank Auto Control

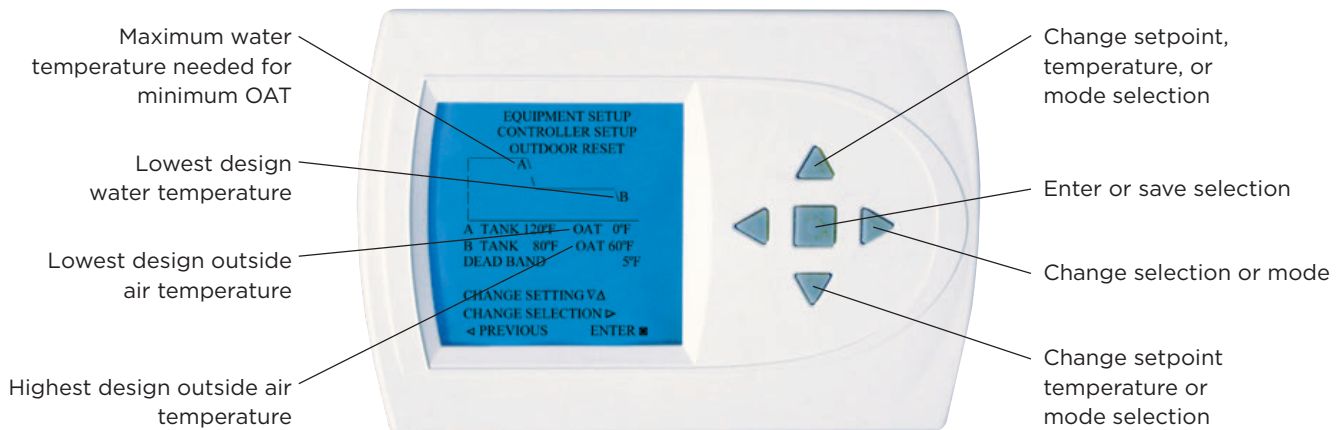
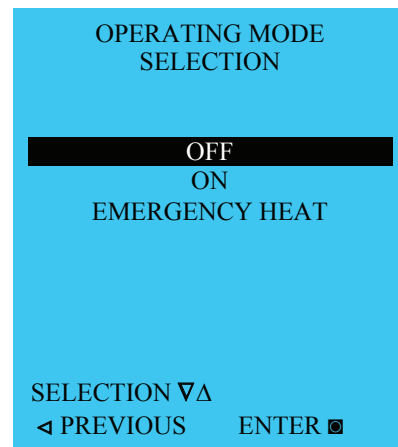

HydroZone Controller Instructions

Wiring Schematic

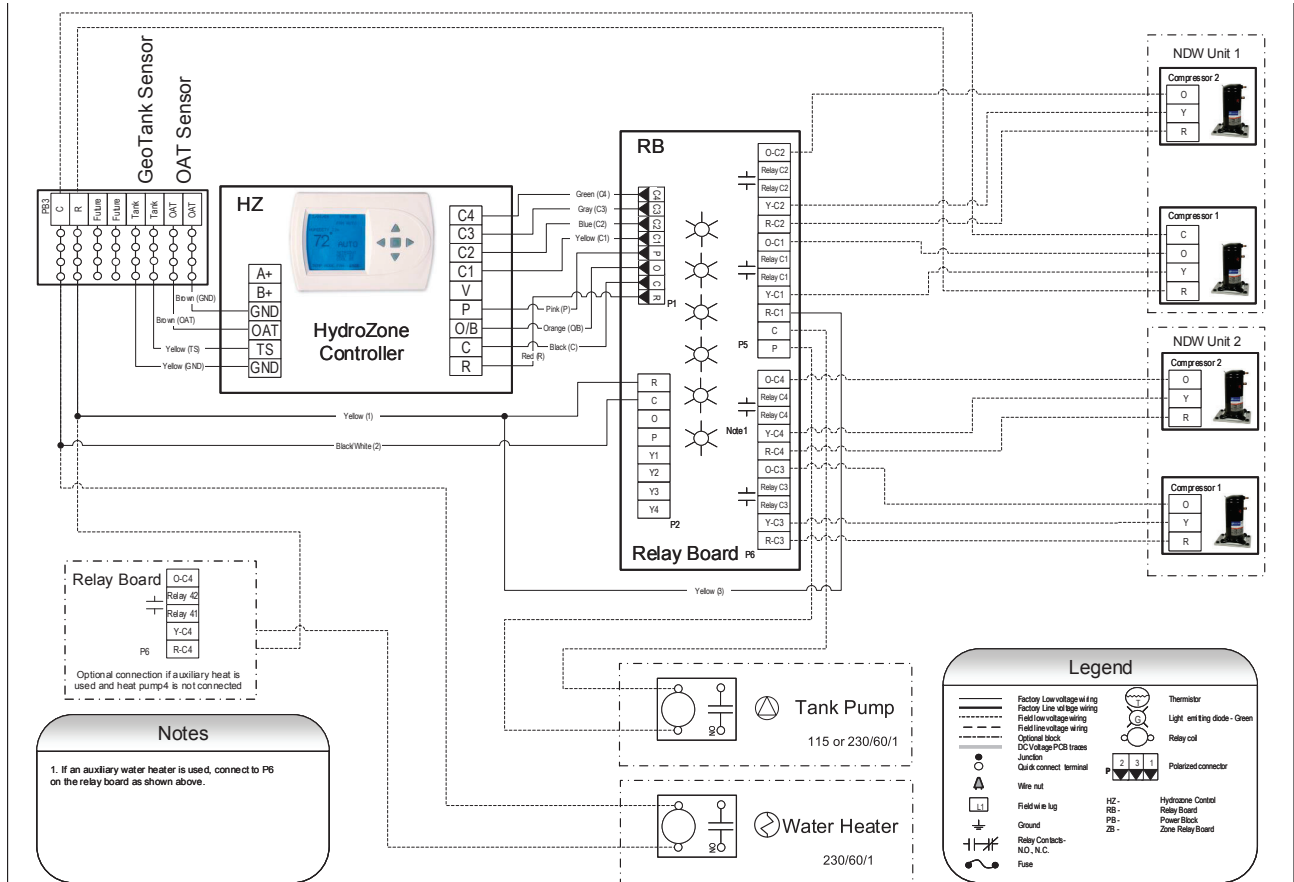

Installer Settings

These options are intended to be used by the installer. End users are not advised to change or modify any of these settings. Doing so may make your equipment stop working properly and/or may void the warranty of the controller as well as the equipment hooked up to the controller. To access the installer setting menu, the mode must be set to OFF. **Then, press both the up and down arrow keys at the same time for at least 5 seconds to enter the installer screen.** After initial power-up, you re-enter installer setup. If no selection is made within 30 seconds, the controller will return to the main screen.

Controller Setup

Options to select from:

- Outdoor Reset - This control mode uses the outdoor reset algorithm to continuously adjust the set point. The set up menu allows selection of Maximum Tank Temperature at a corresponding outdoor air temperature (OAT), and Minimum Tank Temperature at its corresponding OAT. **An outdoor air sensor must be installed.**

Set point A is the maximum tank temperature set point:

Tank temperature (TANK_A) range is 100°F to 130°F (up to 150°F on NHW), and default as 120°F.

Outdoor air temperature (OAT) range is 0°F to 20°F, and default as 0°F.

Set point B is the minimum tank temperature set point:

Tank temperature (TANK_B) range is 70°F to 90°F, and default as 80°F.

Outdoor air temperature (OAT) range is 40°F to 60°F, and default as 60°F.

**EQUIPMENT SETUP
CONTROLLER SETUP
OUTDOOR RESET**

A TANK 120°F OAT 0°F
B TANK 80°F OAT 60°F
DEAD BAND 5°F

CHANGE SETTING ∇Δ
CHANGE SELECTION ▶
< PREVIOUS ENTER ■

HydroZone Controller Instructions

All these temperature settings are with increments of 1°F. The dead band is 2°F to 15°F with increments of 1°F.

Tank Temperature Set point is calculated internally by the outdoor reset algorithm, and updated every 30 minutes if this setup is selected.

Warm Weather Shutdown:

If the warm weather shutdown is selected, the controller will check the outdoor air temperature sensor every 30 minutes. If the temperature is higher than the set temperature selected for 50 continuous hours, then the HydroZone Controller will enter the warm weather shutdown mode. If the temperature drops below the selected setpoint for 5 continuous hours, the controller will exit the warm weather shutdown mode and return back to normal. Warm weather shutdown selections are None, 45, 50, 55, 60, and 65. The factory default is None.

EQUIPMENT SETUP
CONTROLLER SETUP
OUTDOOR RESET
WARM WEATHER SHUTDOWN

NONE

45
50
55
60
65

SELECT OPTION ▽▲
◀ PREVIOUS ENTER ▣

2. Tank Control Auto - This function will put the heat pump in cooling or heating to control to a **single** tank setpoint (default is 120°F). This feature is **not** an auto-changeover control of the conditioned space. If both heating and cooling are desired in the **conditioned space**, then heating and cooling will need to be selected manually with their own tank setpoints in the Tank Control Manual screen. Default temperature for tank setpoint is 120°F with a 5°F deadband. The set range is 40°F to 130°F (up to 150°F on NHW), with increments of 1°F. The dead band is 2°F to 5°F with increments of 1°F. The setpoint can be changed from the main screen by pushing the UP or DOWN buttons.

Selecting ENTER shall take the screen to the CONTROLLER SETUP screen.

This option will maintain the temperature with a tighter deadband and automatically switch the heat pump between heating and cooling to maintain a single setpoint. The factory default is 120°F heating and 5°F dead band.

TANK CONTROL AUTO

TANK SETPOINT 120 F
DEAD BAND 5 F

CHANGE SETTING ▽▲
CHANGE SELECTION ►
ENTER ▣

3. Tank Control Manual - There shall be no automatic changeover from heating to cooling or vice versa. Heating and cooling modes must be selected manually.

If heating fixed is selected, the default temperature for tank setpoint is 120°F with a 10°F deadband. The set range is 80°F to 130°F (up to 150°F on NHW), with increments of 1°F. The dead band is 2°F to 15°F with increments of 1°F. The factory defaults are 120°F heating and 5°F dead band, 80°F cooling and 5°F dead band, and warm weather shutdown is None. When the selection is moved to WARM WEATHER SHUTDOWN..., ENTER shall take the screen to the WARM WEATHER SHUTDOWN screen.

When ENTER is selected, the installer shall be taken to the COOLING screen.

EQUIPMENT SETUP
CONTROLLER SETUP
TANK CONTROL MANUAL
HEATING FIXED

HEATING SETPOINT 120 F
DEAD BAND 10 F

CHANGE SETTING ▽▲
CHANGE SELECTION ►
◀ PREVIOUS ENTER ▣

HydroZone Controller Instructions

If no heating is selected, the screen shall go to the COOLING screen.

If cooling fixed is selected, the default temperature for tank setpoint is 80°F with a 10°F deadband. The set range is 40°F to 85°F, with increments of 1°F. The dead band is 2°F to 15°F with increments of 1°F.

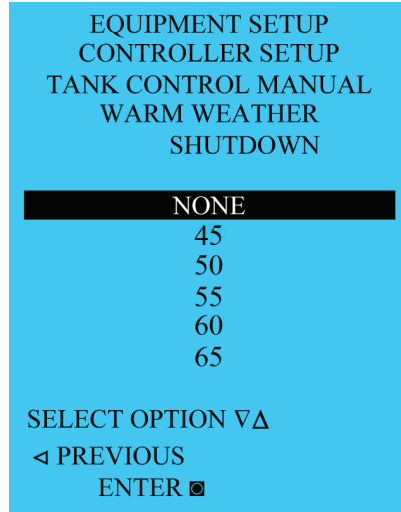
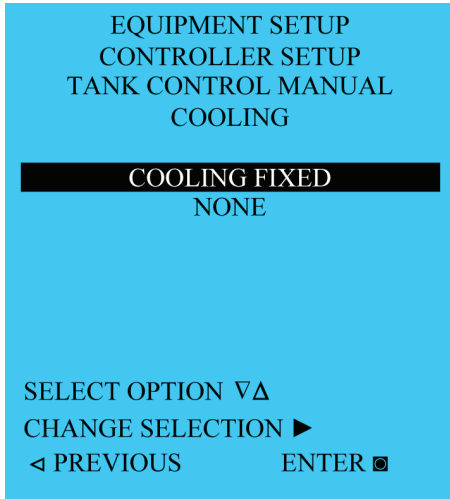

Staging

The controller can control up to four stages of compressors or three compressors and one auxiliary heat. How the unit stages the outputs will be determined by how the outputs are configured. When selecting a dual capacity unit, the next available stage will automatically become dual stage 2. Example: If DUAL 1 STG 1 has been selected for C1 then C2 will automatically be DUAL 1 STG 2.

Staging Screen

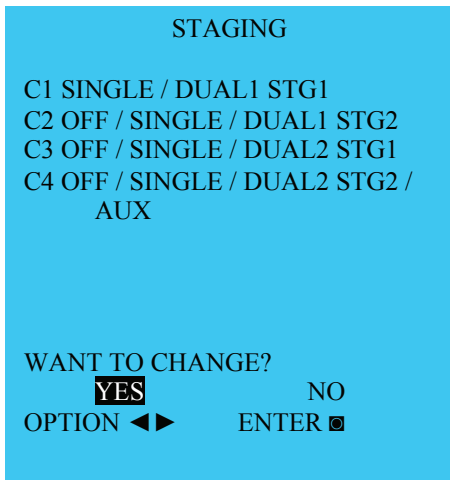

Staging Setup of 1 Dual Compressor and 1 Single with Aux Enabled

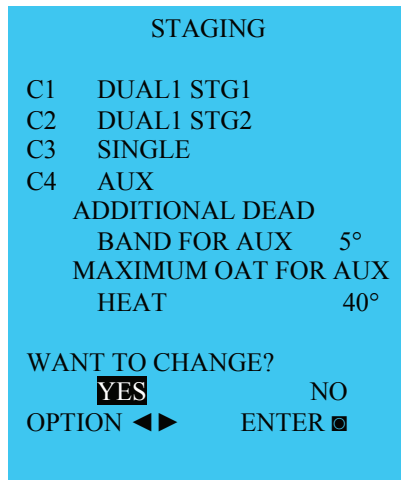

Output	Setup Configuration Options				Factory Defaults
C1	Single	Dual1 Stage1			Single
C2	Single	Dual1 Stage2	Off		Off
C3	Single	Dual2 Stage1	Off		Off
C4/W	Single	Dual2 Stage2	Aux	Off	Off

HydroZone Controller Instructions

If AUX is selected in stage 4, ENTER would take the user to “ADDITIONAL DEAD BAND FOR AUX HEAT” screen and then to “MAXIMUM OAT FOR AUX HEAT” screen.

The “ADDITIONAL DEAD BAND FOR AUX HEAT” would enable the installer to select how much extra dead band should be added on top of the heat dead band before auxiliary heat would come on. The range is between 5° and 15°F.

In the “MAXIMUM OAT FOR AUX HEAT” the installer can select between NONE or a certain outdoor air temperature. If the installer selects a certain temperature for OAT, the AUX heat shall not come on if the outdoor air temperature is above that temperature. The range is between 0°F and 40°F.

If “NONE” is selected, the AUX heat can come on at any time regardless of the outdoor air temperature. **An outdoor air sensor (TSUO2) must be installed for this option.**

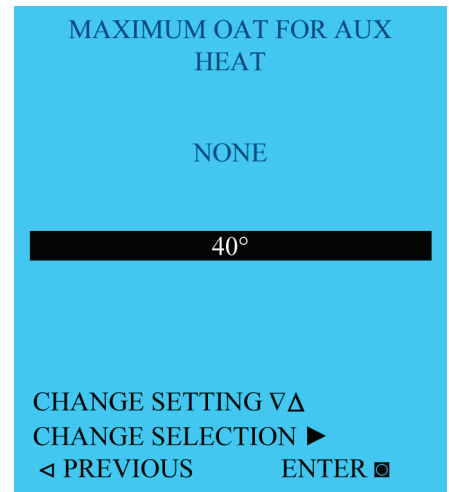

Lead/Lag

If only C1 is selected in the staging, the lead/lag will be selected as “NO”, and can not be changed.

Each compressor output will have an accumulator to keep track of total run time. If any accumulator ran up to the maximum count, all the accumulators shall be reset. Total run time will be reset when lead/lag “NO” is selected. The default setting is “NO”.

- First On – Compressor stage with least amount of accumulated run time.
- First Off – Compressor stage with most amount of accumulated run time.

Factory Defaults

When YES is selected for RESTORE FACTORY DEFAULTS, the controller will restore the factory defaults configuration. Factory default control option is tank control manual. The factory defaults are 120°F heating, 5°F dead band, and warm weather shutdown None.

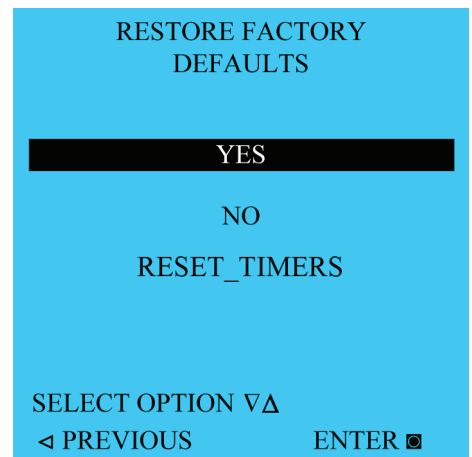

HydroZone Controller Instructions

Service Contact Information

Input dealer info.

INPUT DEALER INFO

BRAND NAME

MODEL NUMBER

SERIAL NUMBER

CONTRACTOR NAME

CONTRACTOR PHONE

SAVE

SELECT OPTION ▽△

◀ PREVIOUS ENTER

◻

DEALER INFO

BRAND NAME:

USE ▽△ TO SCORLL
THRU CHARACTERS

WATER FURNACE

CHANGE LETTER ▽△

◀ PREVIOUS ENTER

◻

When the installer selects ENTER from any of the BRAND NAME, MODEL NUMBER, SERIAL NUMBER, CONTRACTOR NAME, and CONTRACTOR PHONE screens, the main INPUT DEALER INFO screen is shown. In order to save the dealer information in the permanent memory, the installer shall select SAVE from the main INPUT DEALER INFO screen and hit ENTER. The following screen is shown summarizing the information the installer has inserted in the previous screens.

BRAND NAME
WATER FURNACE

MODEL NUMBER
NSW018

SERIAL NUMBER
A2345678

CONTRACTOR NAME
JOHN SMITH

CONTRACTOR PHONE
###-###-####

◀ PREVIOUS SAVE ◻

HydroZone Parts List

Part Number	Quantity	Description
96P697-01	1	Mass Label Sheet
12P546-01	1	8 Position Terminal Block
45C394-01	1	Control Box
45C394-02	1	Control Box Cover
11P813-00	1	Wire Kit
91P001A18	6	Screw #6-32 X 5/8
17P554-01	1	HydroZone Controller
17P555-01	1	Low Voltage Relay Board
91P001A43	4	Screw #10-24 X 3/8
91P008A12	1	Nut #10-32

Compressor & Thermistor Resistance

Thermistor Temperature		Resistance in Ohms
°F	°C	
5	-15	758
14	-10	789
23	-5	822
32	0	855
41	5	889
50	10	924
59	15	960
68	20	997
77	25	1035
86	30	1074
95	35	1113
104	40	1153
113	45	1195
122	50	1237
131	55	1279
140	60	1323
149	65	1368
158	70	1413
167	75	1459
176	80	1506
185	85	1554
194	90	1602
203	95	1652
212	100	1702

2/15/10

Model	208-230/60/1		208-230/60/3	460/60/3	575/60/3
	Run	Start	Start	Start	Start
120	0.37	0.97	0.610	2.520	3.740
180	0.312	0.874	0.419	1.614	2.507

Note: Resistance values may vary +/- 7%.

10/14/24

Reference Calculations

Heating Calculations: $LWT = EWT - \frac{HE}{GPM \times 500^*}$	Cooling Calculations: $LWT = EWT + \frac{HR}{GPM \times 500^*}$
--	--

NOTE: * When using water. Use 485 for 15% methanol/water or Environol solution.

Legend

Abbreviations and Definitions

ELT = entering load fluid temperature to heat pump	PSI = pressure drop in pounds per square inch
LLT = leaving load fluid temperature from heat pump	FT HD = pressure drop in feet of head
LGPM = load flow in gallons per minute	KW = kilowatt
LWPD = load heat exchanger water pressure drop	HR = heat rejected in MBTUH
EST = entering source fluid temperature to heat pump	TC = total cooling capacity in MBTUH
LST = leaving source fluid temperature from heat pump	COP = coefficient of performance (HC/KW x 3.413)
SGPM = source flow in gallons per minute	HC = heating capacity in MBTUH
SWPD = source heat exchanger water pressure drop	HE = heat of extraction in MBTUH
EER = cooling energy efficiency (TC/KW)	

Notes to Performance Data Tables

The following notes apply to all performance data tables:

- Three flow rates are shown for each unit. The lowest flow rate shown is used for geothermal open loop/well water systems with a minimum of 50°F EST. The middle flow rate shown is the minimum geothermal closed loop flow rate. The highest flow rate shown is optimum for geothermal closed loop systems and the suggested flow rate for boiler/tower applications.
- Entering water temperatures below 40°F assumes 15% antifreeze solution.
- Interpolation between ELT, EST, and GPM data is permissible.
- Operation in the gray areas is not recommended.

Preventative Maintenance

Unit Heat Exchanger Maintenance

1. Keep all air out of the water or antifreeze solution.
2. Keep the system under pressure at all times. Closed loop systems must have positive static pressure or air vents may draw air into the system.

NOTES: If the installation is in an area with a known high mineral content in the water, it is best to establish with the owner a periodic maintenance schedule for checking the water-to-refrigerant heat exchanger on a regular basis. Should periodic cleaning be necessary, use standard cleaning procedures. Generally, the more water flowing through the unit, the less chance there is for scaling. Low GPM flow rates produce higher temperatures through the heat exchanger. To avoid excessive pressure drop and the possibility of metal erosion, do not exceed GPM flow rate as shown on the specification sheets for each unit.

Replacement Procedures

When contacting the company for service or replacement parts, refer to the model number and serial number of the unit as stamped on the serial plate attached to the unit. If replacement parts are required, mention the date of installation of the unit and the date of failure, along with an explanation of the malfunctions and a description of the replacement parts required.

In-Warranty Material Return

Material may not be returned except by permission of authorized warranty personnel. Contact your local distributor for warranty return authorization and assistance.

Troubleshooting

Aurora Control System

NOTE: Refer to the Aurora Base Control Application and Troubleshooting Guide and the Instruction Guide: Aurora Interface and Diagnostics (AID) Tool for additional information.

To check the unit control board for proper operation:

1. Disconnect thermostat wires at the control board.
2. Jumper the desired test input (Y1, Y2, W, O or G) to the R terminal to simulate a thermostat signal.
3. If control functions properly:
 - Check for thermostat and field control wiring (use the diagnostic inputs mode).
4. If control responds improperly:
 - Ensure that component being controlled is functioning (compressor, blower, reversing valve, etc.).
 - Ensure that wiring from control to the component is correct.
 - Refer to the Aurora Base Control Application and Troubleshooting Guide and the Instruction Guide: Aurora Interface and Diagnostics (AID) Tool for additional information.

Refrigerant Systems

To maintain sealed circuit integrity, do not install service gauges unless unit operation appears abnormal. Compare the change in temperature on the air side as well as the water side to the Unit Operating Parameters tables. If the unit's performance is not within the ranges listed, and the airflow and water flow are known to be correct, gauges should then be installed and superheat and subcooling numbers calculated. If superheat and subcooling are outside recommended ranges, an adjustment to the refrigerant charge may be necessary.

NOTE: Refrigerant tests must be made with hot water generator turned "OFF". Verify that air and water flow rates are at proper levels before servicing the refrigerant circuit.

Aurora Interface Diagnostic (AID) Tool

Aurora Input-Output Diagnostics



Troubleshooting the Aurora logic board can be accomplished using nothing more than a couple of jumper wires and a volt meter. The process can be simplified with the use of the Aurora Interface Diagnostic Tool (AID Tool). The AID Tool allows the user to see lockout and fault history information, thermostat inputs, sensor inputs, system outputs, timer, etc.

Aurora ABC Checkout

Before replacing the Aurora ABC control board the proper troubleshooting steps must be taken to ensure that the board is the root cause. On the following pages are several flow charts that will assist in checking the control board. If it is found that the control board is faulty, contact technical services for a replacement part.

LED Displays

Slow Flash = 1 second on and 1 second off

Fast Flash = 100 ms on and 100 ms off

Flash Code = 100 ms on and 400 ms off with a 2 second pause between packages

SW1 Operation

Holding SW1	Description of Operation	LED
2 to 5 sec	Enter Test Mode	Green LED Slow Flash
5 to 10 sec	Enter ECM Configure Mode	Yellow LED Off
50 to 60 sec	Reset Configure Mode (default)	Yellow LED Off
> 60 sec	SW1 Operation Cancel	Yellow LED Back to Normal

"SW1 operation cancel," holding SW1 for longer than 60 seconds operation will be cancelled. Yellow LED will go back to normal operation.

Fault Retries Before Lockout

Type of Fault	Total Tries Before Lockout
High Pressure	3 Retries
Low Pressure	3 Retries
Freeze Detection 1 - (Coax)	3 Retries
Freeze Detection 2 - (Air coil)	3 Retries
Condensate Overflow	3 Retries
Over/Under Voltage Shutdown	No Lockout
Compressor Monitor	No Retry
Freeze Detection Sensor Error (Sensor is out of range)	No Retry

Preliminary Checkout Procedure

Troubleshooting liquid source heat pumps with Aurora controls is an easy and straight forward process. Most service problems are related to water flow (insufficient or too cold). Also, most service problems can be fixed without connecting refrigerant manifold gauges.

The first item to check is system performance which can be done in six steps. Before beginning make sure the hot water generator pump is disconnected.

STEP 1: Check and/or set source water flow. Refer to the install manual for the specific piece of equipment's correct water flow setting.

STEP 2: Check the temperature difference through the coaxial heat exchanger and compare to the Operating Parameters table in the equipment install manual.

STEP 3: Check the air temperature rise/drop and compare to the Operating Parameters table in the equipment's installation manual.

STEP 4: If the first three steps check out, perform a heat of extraction/rejection test as described in the Water Side Analysis: Heat of Extraction/Rejection section to confirm proper operation.

STEP 5: If any or all of the above steps do not check out, be sure that the air coil and filter are clean.

STEP 6: Check superheat and subcooling by placing refrigeration gauges on the unit. Compare superheat and subcooling values with the charts in the equipment installation manual.

If the above six steps do check out, it would be safe to assume that the unit is performing well and the problem must lie elsewhere, i.e. excessive heat loss/gain in the structure or duct system, (undersized duct and/or registers, etc.)

If you suspect a specific problem, refer to the Table of Contents and select the reference that most closely matches the situation encountered. If problems persist after completing the preliminary checkout procedure, refer to the Troubleshooting Checklist. Select the problem which is closest to the situation you have encountered.

Troubleshooting Checklist

Equipment will not start or operate

- Follow the troubleshooting flow charts to find root cause.

High pressure lockout in the heating mode

- Check for air flow interruption from one or more of the following: inoperative blower, dirty filters or air coil, blocked return air grille, closed or blocked supply registers, restricted supply or return duct, zone dampers, etc. If airflow is suspected as being a problem, make a quick check using the following example: Velocity in a supply duct should not exceed 1000 fpm and 700 fpm in return ducts. For this example we will use an model 038 which has a maximum rating of 1500 cfm at 0.50 static (Refer to the blower performance tables in the install manual for your particular piece of equipment). Using the formula: Area in square feet equals quantity in cfm divided by velocity in fpm ($A=cfm/fpm$), 1.57 sq. ft. is needed for the supply duct and 2.14 sq. ft. is needed for the return duct. Refer to the troubleshooting flow charts if a problem with the blower motor or logic board is suspected.
- Check for blocked or seized expansion device.
- Make sure the discharge pressure is within the operating range shown in this product manual.
- The unit may be overcharged; check superheat and sub cooling. If this problem is verified, recharge using approved methods.

High pressure lockout in the cooling mode

- Water flow may be restricted or inadequate. Verify in accordance with the pressure drop tables shown in product install manual. Also, look for the following: solenoid valve may not be opening on well water units, pump(s) may be inoperative in the flow center, debris may be blocking coil (back flush using at least 20 PSI), or air may be in the loop (flush loop).
- Water to refrigerant heat exchanger may be fouled with debris. If so, back flush with at least 20 psi of water pressure.
- If mineral accumulation is evident, clean the heat exchanger with acid.
- Entering air temperature may be too high. Equipment is designed for a maximum of 85°F DB and 71°F WB.
- Check for a seized or blocked expansion device.
- The unit may be overcharged; check superheat and sub cooling. If this problem is verified, recharge using approved methods.

Low pressure lockout in heating mode

- If equipment is installed in a low temperature area (below 50°F), install a crankcase heater, then protect the unit from the elements.
- Water flow may be restricted or inadequate. Verify in accordance with the pressure drop tables shown in this product manual. Also, look for the following: solenoid valve may not be opening on well water units, pump(s) may be inoperative in the flow center, debris may be blocking coil (back flush using at least 20 PSI), or air may be in the loop (flush loop).
- Check for a seized or blocked expansion device.

- Return air temperature may be below 50°F. Block off air coil temporarily to improve flow of refrigerant through the system. Air below 50°F cannot be tolerated on a continuing basis. Correct the problem.
- Refrigerant may be low. Check for leaks, reclaim refrigerant, repair if necessary, recharge using approved methods.

Low pressure lockout in the cooling mode

- Check for inadequate air flow. Follow the same procedure as shown for a high pressure lockout in the heating mode.
- Check for a seized or blocked expansion device.
- Refrigerant charge may be low.

Water flow lockout in either the heating or cooling mode

- Water flow may be restricted or inadequate. Verify in accordance with the pressure drop tables shown in product install manual. Also, look for the following: solenoid valve may not be opening on well water units, pump(s) may be inoperative in the flow center, debris may be blocking coil (back flush using at least 20 PSI), or air may be in the loop (flush loop).
- Disconnect freeze sensor from control and measure the resistance. Cross reference with the Thermistor Data table.

Reversing valve does not operate

- Disconnect solenoid and check for continuity across coil. Replace coil if continuity is not found.
- If stuck reversing valve is suspected, restrict airflow in heating mode (to build pressure), then switch immediately to the cooling mode.

Control Board Troubleshooting Steps

1) General Check

- If any new device was installed, or any wiring was changed, check the connections to ensure the wiring is correct, and all the wires are in good condition.
- Verify all the plugs are securely connected and in good condition.
- Check the DIP switch (SW2) positions are correct.
- Measure 24 VAC between R and C. (The actual reading may be from 18 to 30 VAC). Check the incoming power and the power transformer if the R and C voltage reading is not correct.

2) No LEDs are On

- Check 24 VAC on board.
- Check the 3 amp fuse. Replace the fuse if needed.
- Verify transformer circuit breaker has not tripped if no low voltage is present.
- Disconnect the thermostat connection P1.
- Replace the Aurora base control board.

3) Red LED Flash Code

Input Fault (Code 1) – Indicates that both O and W input signals are present. Disconnect the thermostat connector from the ABC board and then cycle power to the board. If the fault does not reappear, then the problem is between the thermostat and the thermostat connector. Otherwise, replace the ABC board.

High Pressure Fault (Code 2) – Indicates the system pressure has exceeded 600 psi (R-454B) which may have been caused by low water flow in cooling, (check coaxial heat exchanger for mineral build-up) or low air flow in heating (check filters and coil for dirt build-up). Measure P4-9 and C is 24 VAC. If not, replace ABC. Check the heat pump refrigeration system. Cycle the power to reset the system. Measure P4-10 and C is 24 VAC. If not, replace the high pressure sensor.

Low Pressure Fault (Code 3) – Indicates low pressure switch has opened which may indicate a loss of system charge, system restriction, or frozen heat exchanger. Measure P4-7 and C is 24 VAC. If not, replace ABC. Check the heat pump refrigeration system. Cycle the power to reset the system. Measure P4-8 and C is 24 VAC. If not, replace the low pressure sensor. Refrigerant may be low. Check for leaks, reclaim refrigerant, repair if necessary, pump down and recharge the system to the quantity of refrigerant shown on the unit nameplate.

Freeze Detection 1 Fault (Code 5) – Indicates low or no water flow; low system charge; or faulty expansion device in heating mode. Make sure the DIP switch FP1 (SW2-1) selection matches the application. Measure the temperature on the refrigerant line next to the freeze detection thermistor. Disconnect the connector P4. Measure the resistance reading between P4-3, P4-4. Refer to the Thermistor Data table, find the corresponding temperature data. Compare the data with the temperature measurement from the refrigerant line. The temperature should be within +/- 2° F. If not, replace the thermistor.

Other items to check when troubleshooting a water flow lockout are superheat, water flow through the coaxial heat exchanger and antifreeze composition. High superheat in heating will lower the refrigerant line temperature where the freeze detection thermistor is located. In this case, check the expansion device. Closed loop systems are rated at 3 gpm/ton. If a closed loop system is running at less than 3 gpm/ton, the temperature difference between the refrigerant line and the actual leaving water temperature will be greater and could lead to possible water flow lockouts.

Over/Under Voltage Shutdown Fault (Code 8) – Indicates the control voltage is or had been outside the range of 18 to 30 VAC for more than 15 minutes. Using a voltage meter, check the incoming power line voltage is within + or – 25%. If not, there is a power line issue. Check the secondary of the control transformer with a voltage meter. The voltage should be 18 to 30 VAC. If not, replace the control transformer.

Freeze Detection FP1 Sensor Fault (Code 11) – Indicates the freeze detection sensor is out of range. Disconnect the connector P4. Measure the resistance reading between P4-3, P4-4. Refer to the Thermistor Data table, find the corresponding temperature data. Compare the data with the temperature measurement from the refrigerant line. The temperature should be within +/- 2°F. If not, replace the thermistor.

Compressor First Stage Will Not Start – Measure the voltage output between P5-4 and P5-5, P5-7 and P5-8. The reading should be 24 VAC. If 24 VAC is not present check transformer output, thermostat wiring, current fault status, etc.

Compressor Second Stage Will Not Start – Measure the voltage output between P5-6 and P5-8. The reading should be 24 VAC. If 24 VAC is not present, check DIP switch settings, thermostat operation, and thermostat wiring.

No Alarm Output – Measure the voltage output between P2-4 and C. The reading should be 24 VAC or a pulsed 24 VAC dependent on the selection of SW2-7. If SW2-8 is set for reheat, the alarm output will be used to control the hot gas reheat valve and will not show lockout information.

Accessory Relay Does Not Operate – Measure the continuity between P2-2 and P2-3. It should read closed when relay is engaged. If this is not correct, check SW2-4 and SW2-5 settings.

No Lockout Output – Measure the voltage output between P1-1 and C. The reading should be 24 VDC or a pulsed 24 VDC dependent on the selection of SW2-7. If voltage is not present, make sure the unit is in lockout and not fault retry.

Auxiliary Heater Does Not Function – Measure the voltage output between P3-1, P3-2, and P3-3, P3-4. The output should be 24 VDC. If voltage is not present, check thermostat operation and wiring.

Control Board Troubleshooting Steps cont.

Loop Pump Does Not Start – The loop pump is controlled by the AXB board. Check to make sure the control board is powered by taking a voltage reading across R and C to check for 24VAC. If 24VAC is not present check the wiring connections, 24VAC is supplied to the AXB through the harness connected to P9. Next check to make sure the ABC is attempting to run the compressor, the loop pump will only run when the ABC is commanding CC on, the pump slave input is active, or the AXB has lost communication with the ABC. Please refer to troubleshooting flow charts for additional checks on the loop pump.

5) Operation Modes

Enter First Stage Heating – Remove P1. Place a jumper between R and Y1.

Enter Second Stage Heating – Remove P1. Place a jumper between R, Y1 and Y2. This is for SW2-6 set to “OFF” position.

Enter Third Stage Heating – Remove P1. Place a jumper between R, Y1, Y2 and W.

Enter First Stage Cooling – Remove P1. Place a jumper between R, O and Y1.

Enter Second Stage Cooling – Remove P1. Place a jumper between R, O, Y1 and Y2.

Enter Emergency Heating – Remove P1. Place a jumper between R and W.

Enter Blower Only Mode – Remove P1. Place a jumper between R and G.

Enter Reheat Mode – Remove P1. Place a jumper between R and DH. (SW2-8 must be off)

These notes are for SW2-3 set to “ON” position.

Control Board Troubleshooting Flow Charts

Use the following flow charts to aid in troubleshooting the control board.

Compressor Will Not Start Without AID Tool

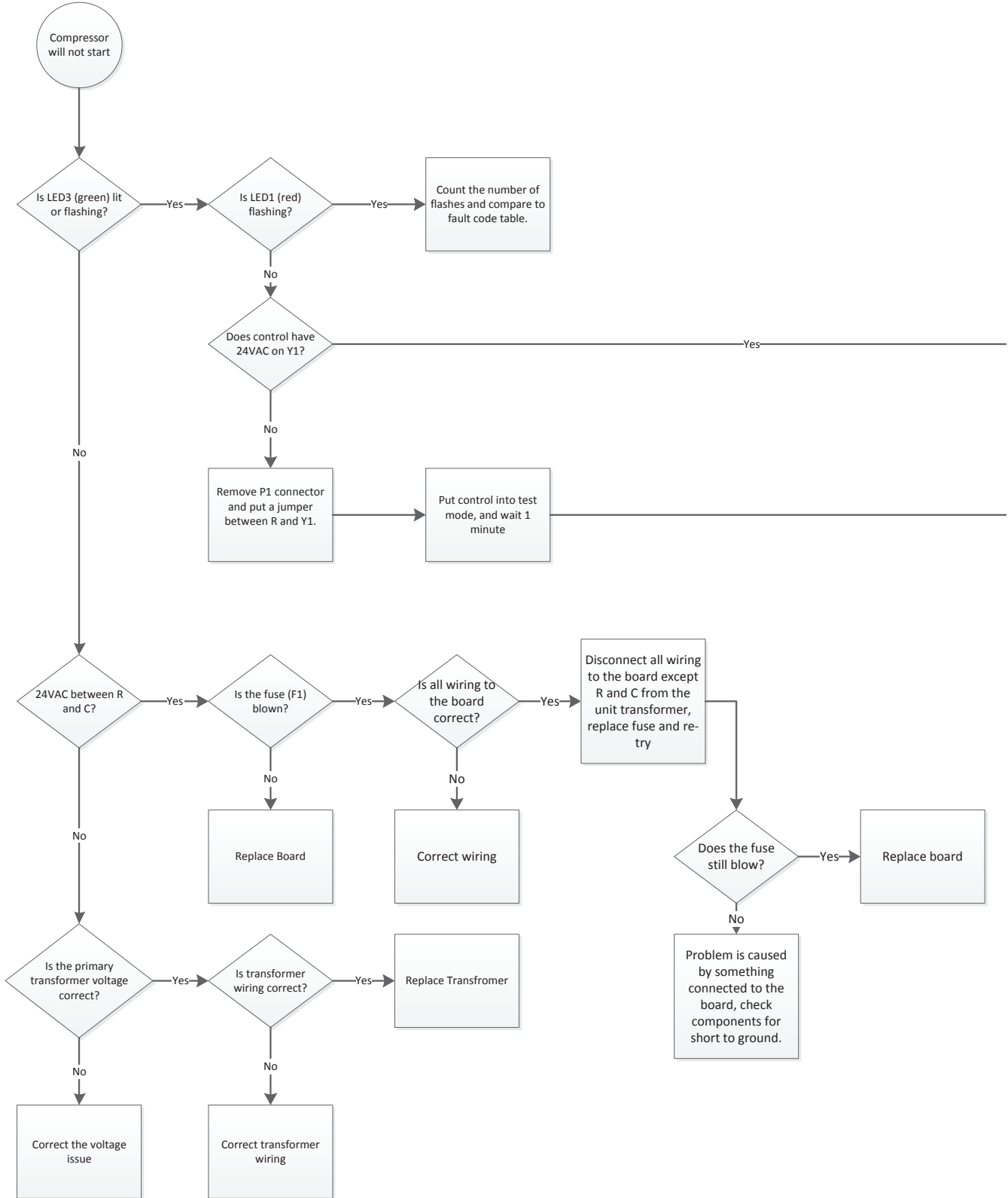

Control Board Troubleshooting Flow Charts cont.

Notes:

1. When measuring 24VAC actual value may be between 18 and 30VAC.

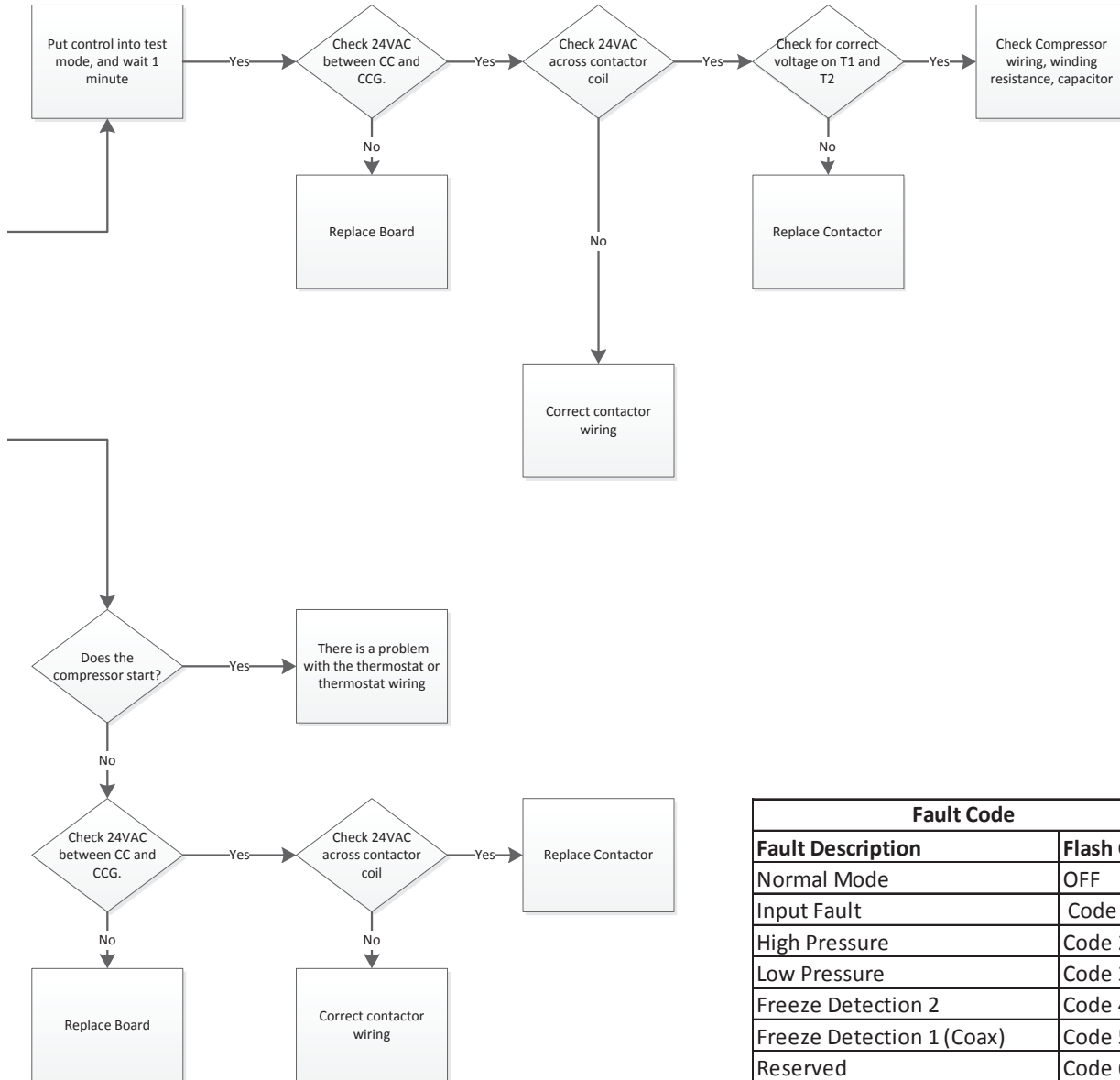

Fault Code	
Fault Description	Flash Code
Normal Mode	OFF
Input Fault	Code 1
High Pressure	Code 2
Low Pressure	Code 3
Freeze Detection 2	Code 4
Freeze Detection 1 (Coax)	Code 5
Reserved	Code 6
Condensate	Code 7
Over/Under Voltage	Code 8
Not Used	Code 9
Freeze Detection Sensor Error	Code 11

NOTE: Refer to the Control Board Troubleshooting Steps for fault descriptions.

Control Board Troubleshooting Flow Charts cont.

Compressor Will Not Start With AID Tool

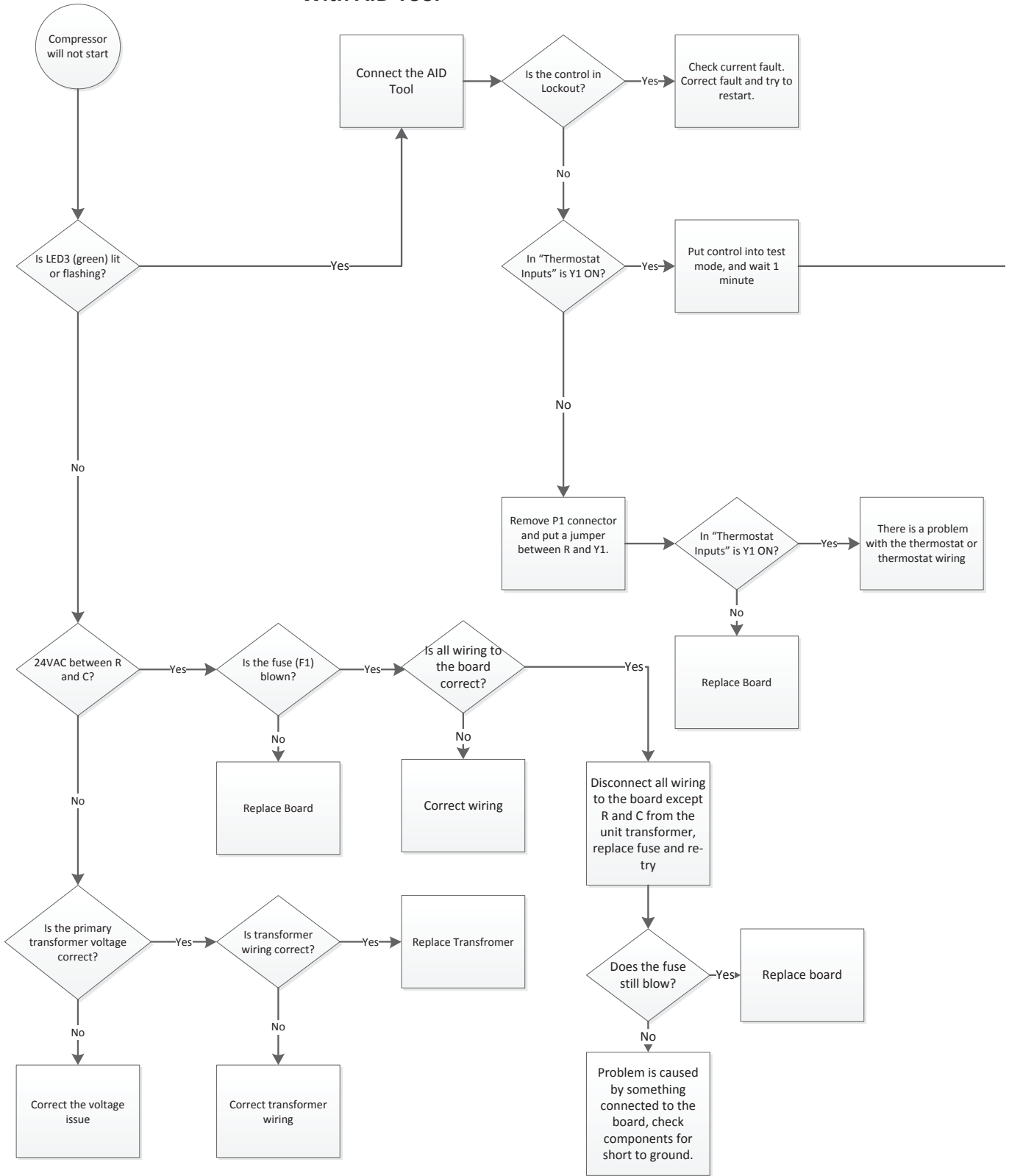

Control Board Troubleshooting Flow Charts cont.

Notes:

1. When measuring 24VAC actual value may be between 18 and 30VAC.

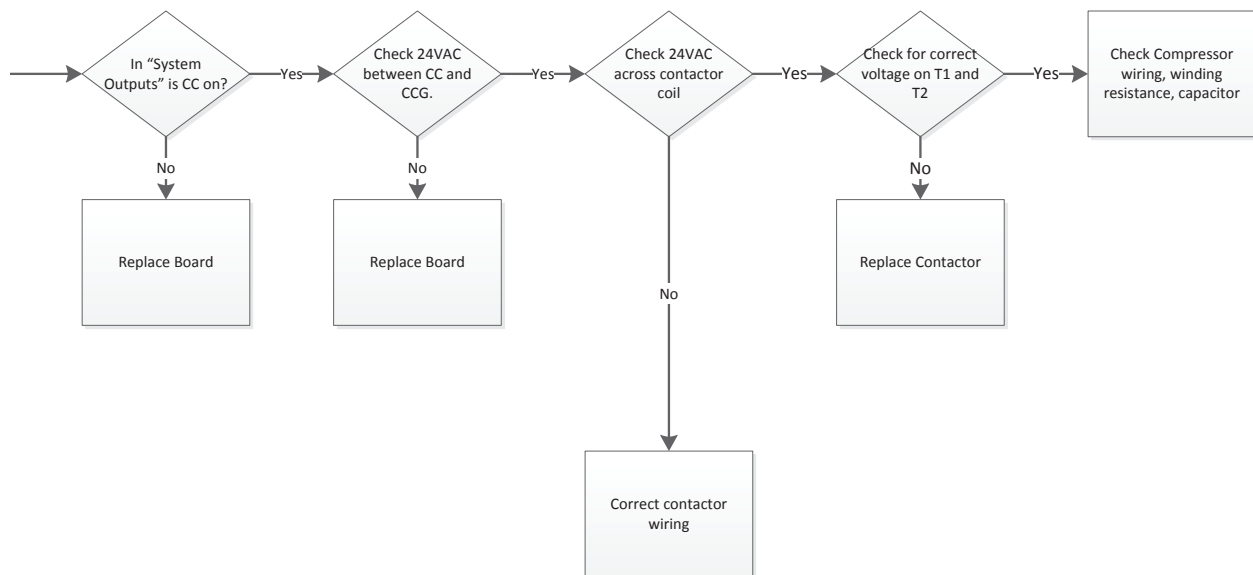

Control Board Troubleshooting Flow Charts cont.

Loop Pump Will Not Start Variable Speed Pump

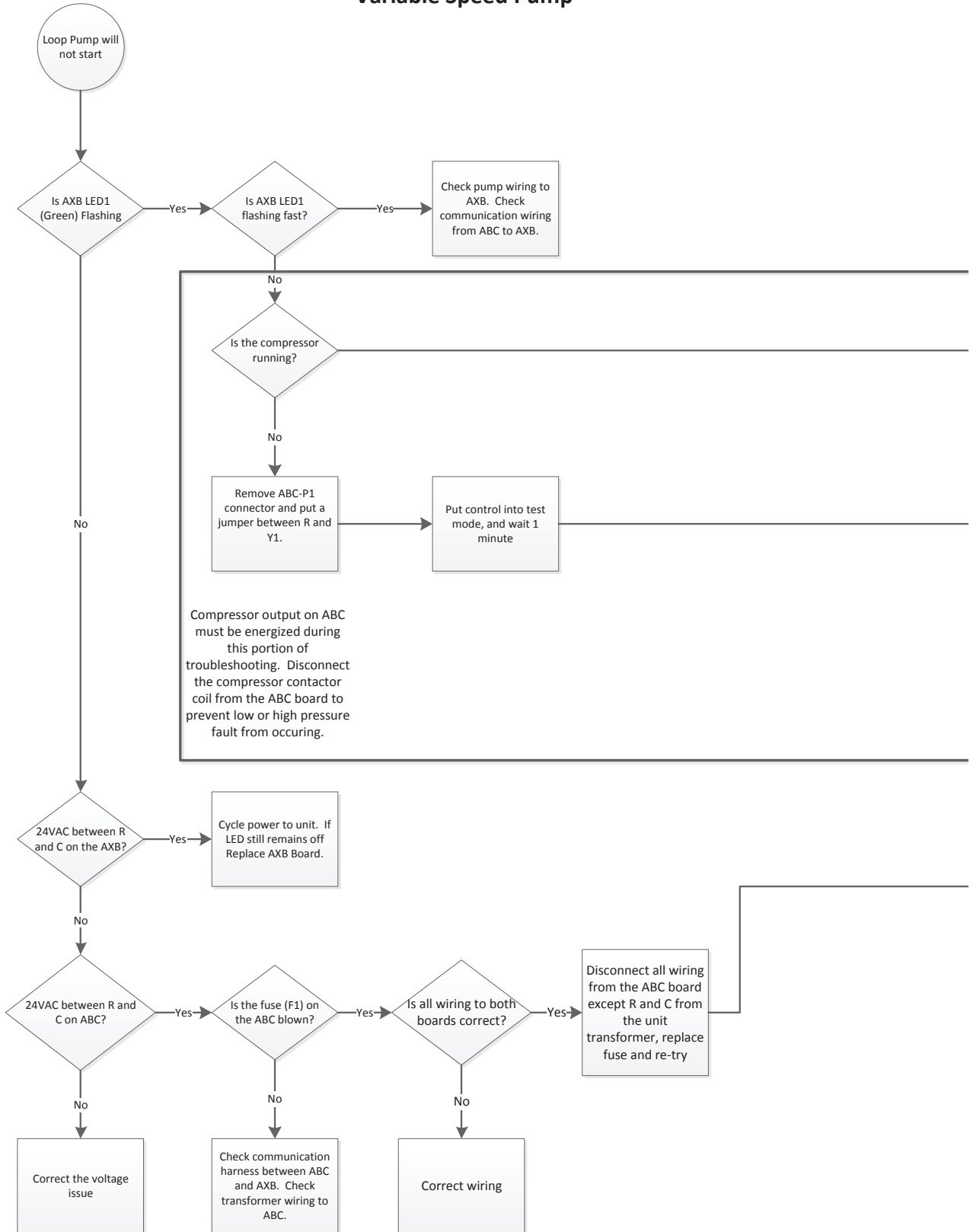

Control Board Troubleshooting Flow Charts cont.

Notes:

1. When measuring 24VAC actual value may be between 18 and 30VAC.
2. When measuring 240VAC actual value may be between 190 and 250 VAC.

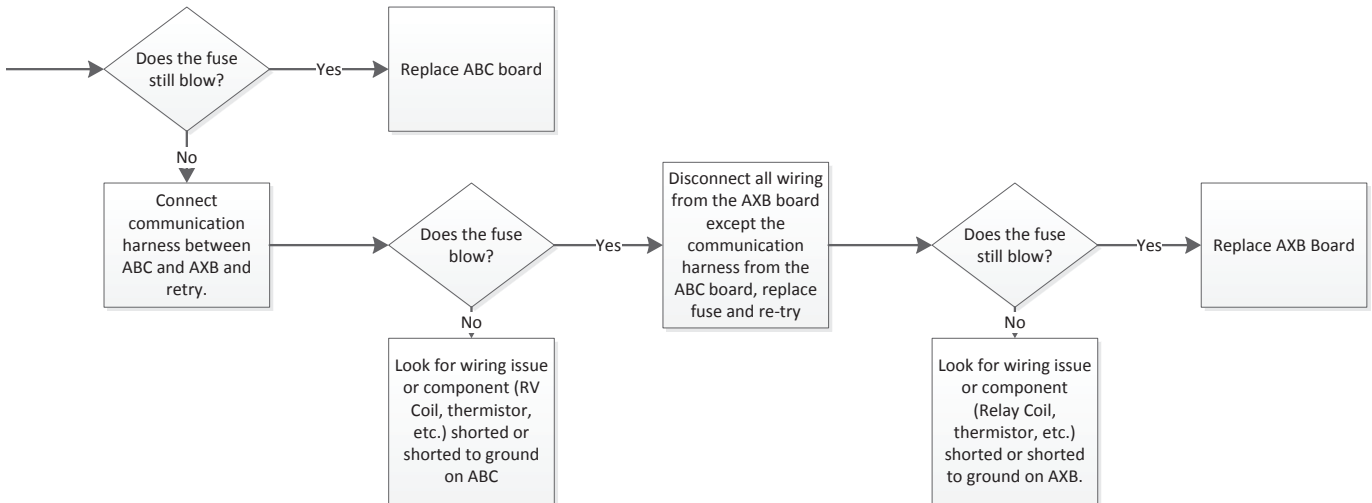
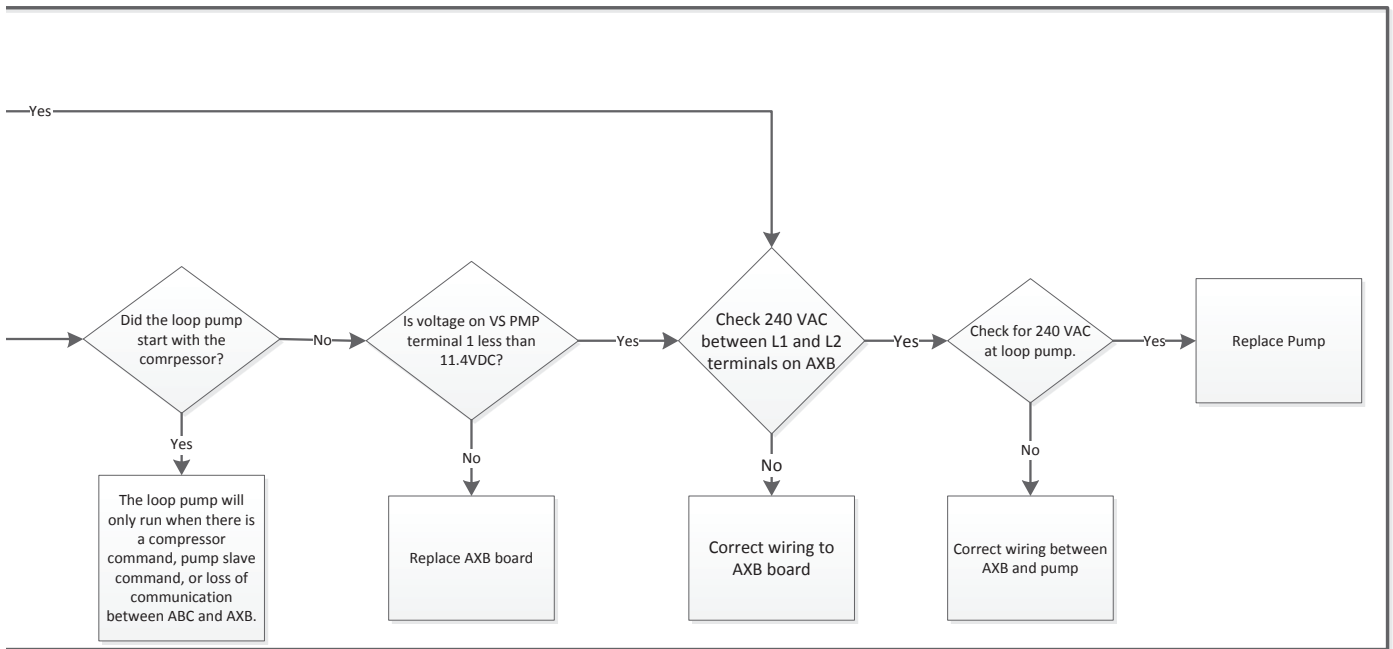

Control Board Troubleshooting Flow Charts cont.

Loop Pump Will Not Start Non Variable Speed Pump

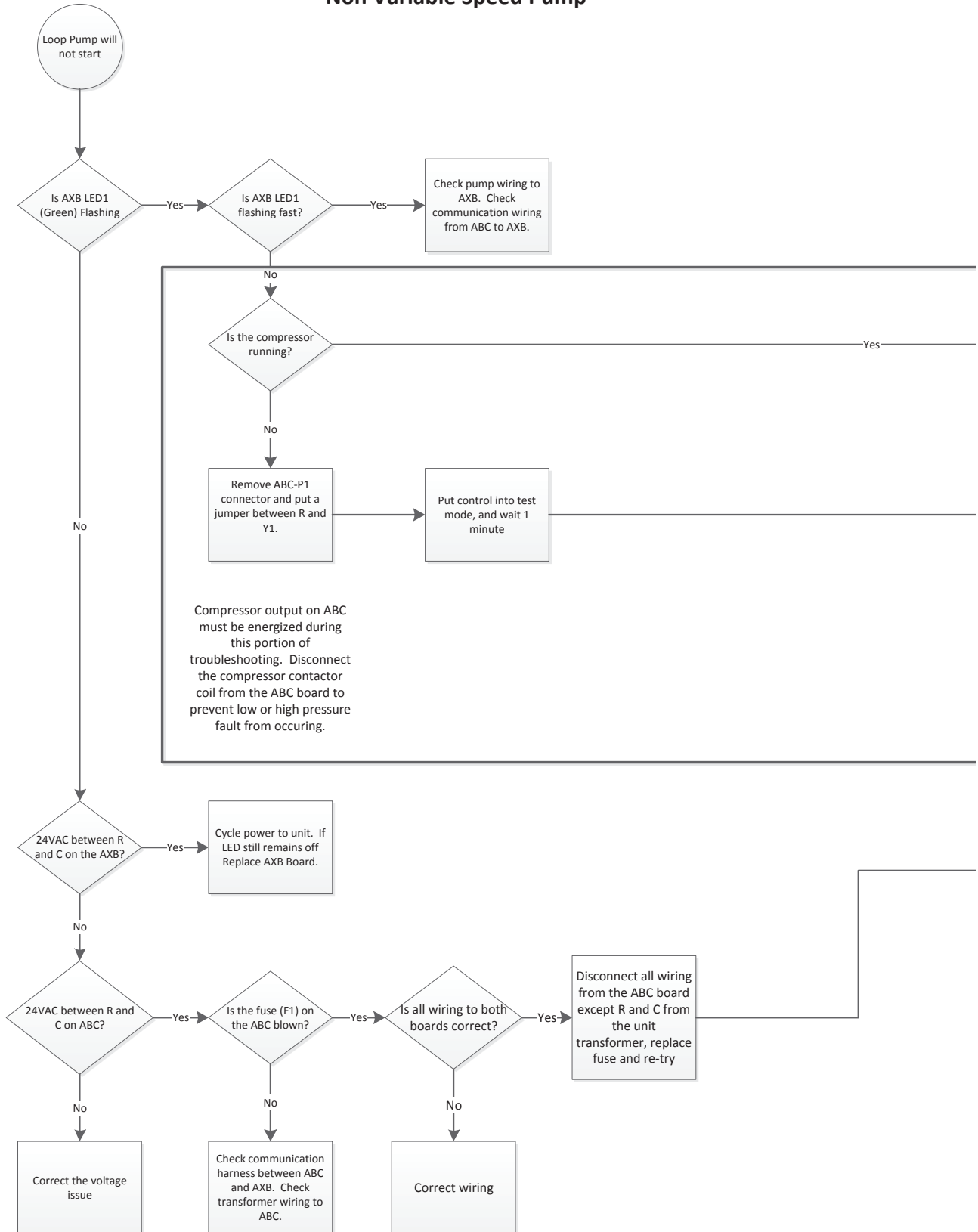

Control Board Troubleshooting Flow Charts cont.

Notes:

1. When measuring 24VAC actual value may be between 18 and 30VAC.
2. When measuring 240VAC actual value may be between 190 and 250 VAC.

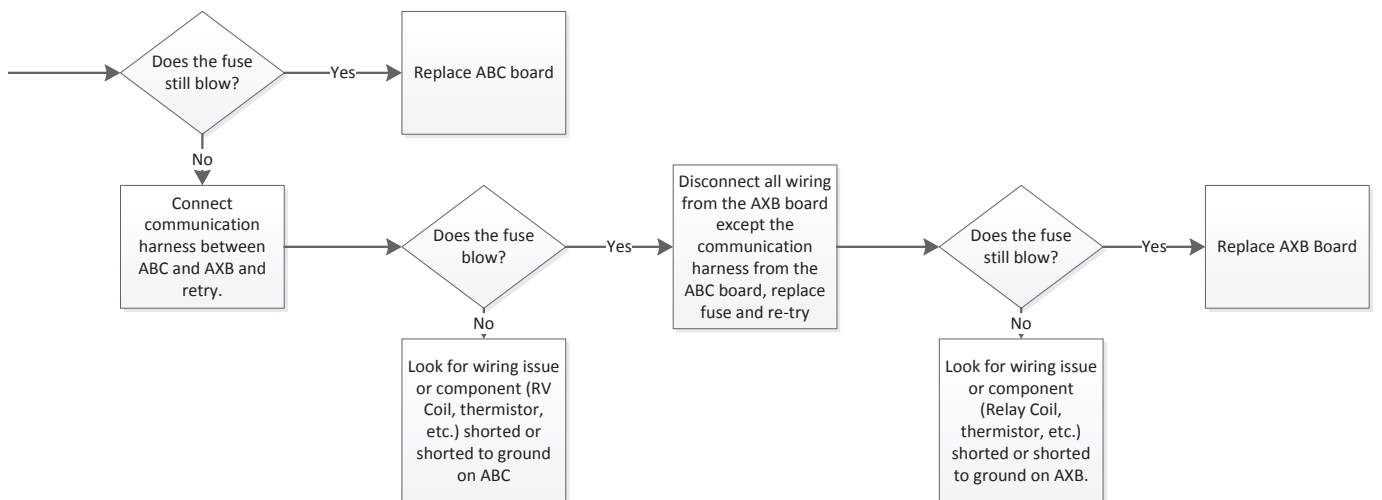
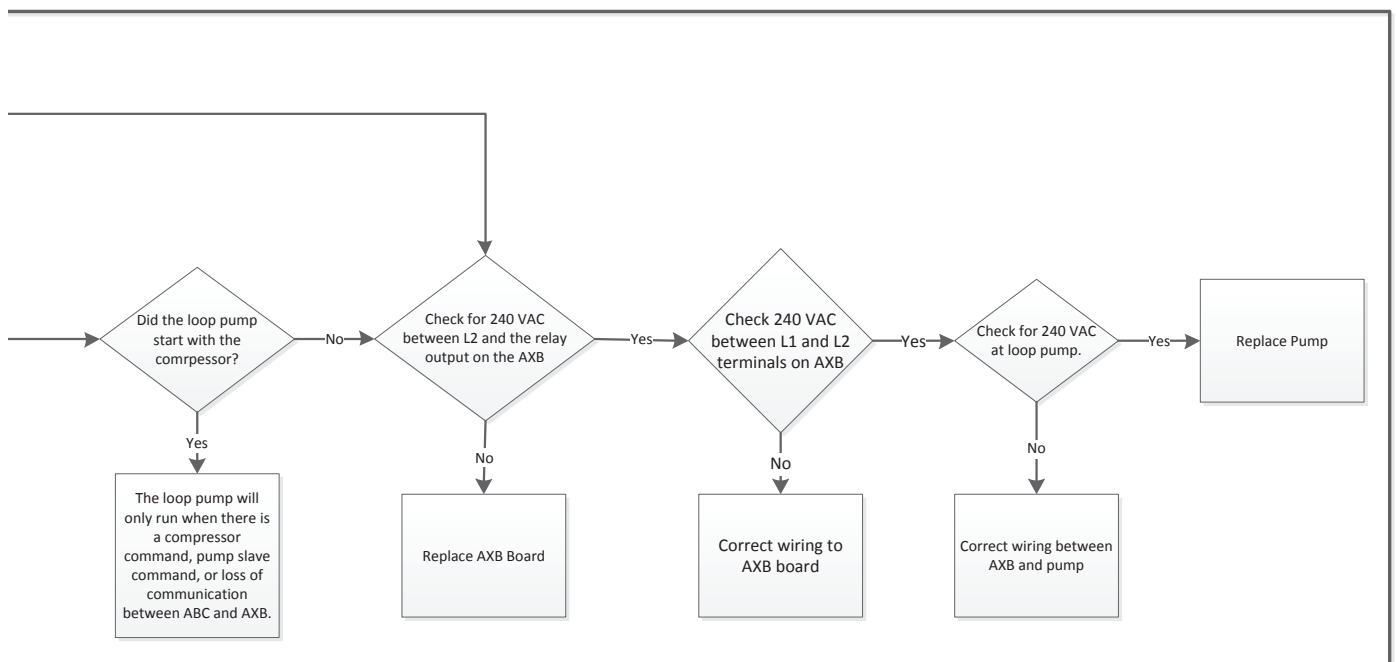

Communicating Thermostat Troubleshooting Guide

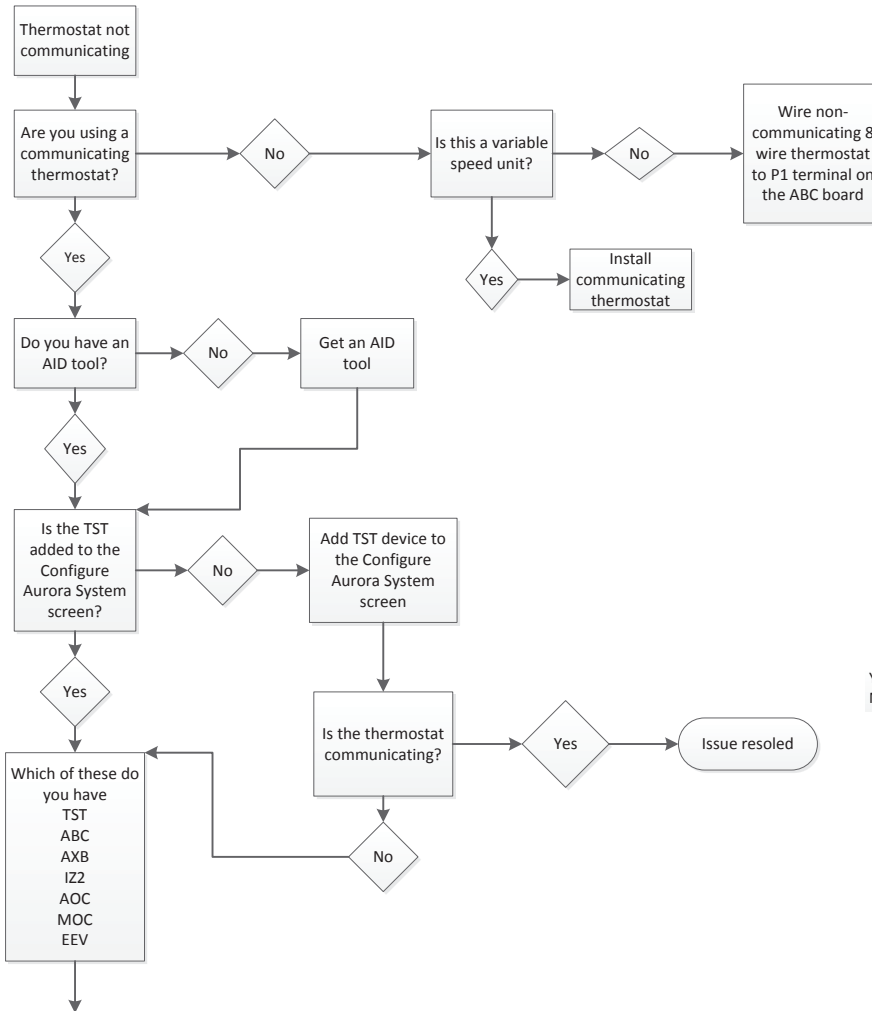

Continue to Next Page

Configure Aurora System Screen

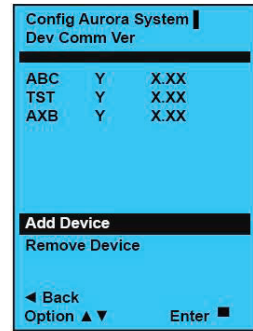

Single and Dual Capacity unit

Y – Active Communication
 N – Device has been found, but communication has failed.

Communicating Thermostat Troubleshooting Guide cont.

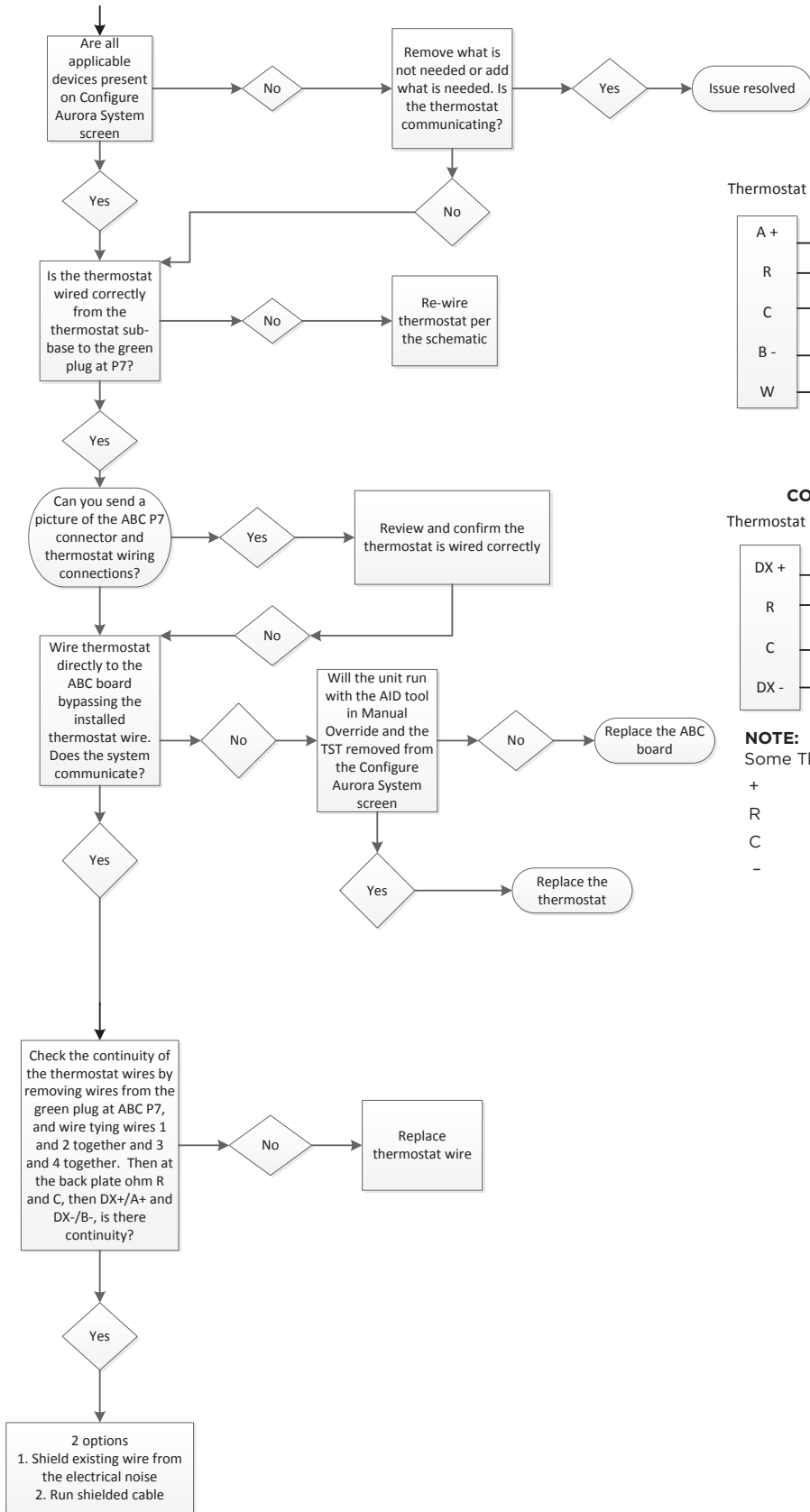

TPCM32U03A*/TPCM32U04A*

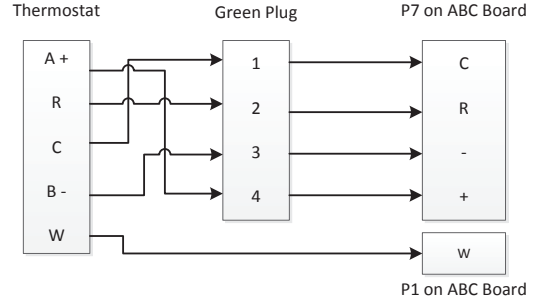

TPCC SERIES
COLOR TOUCHSCREEN THERMOSTAT

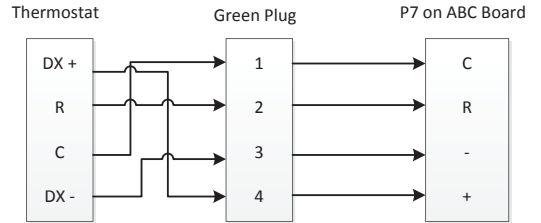

NOTE:
Some Thermostats will be:

- +
- R
- C
-

Control Board Signals

To Check for 24VAC between R and C

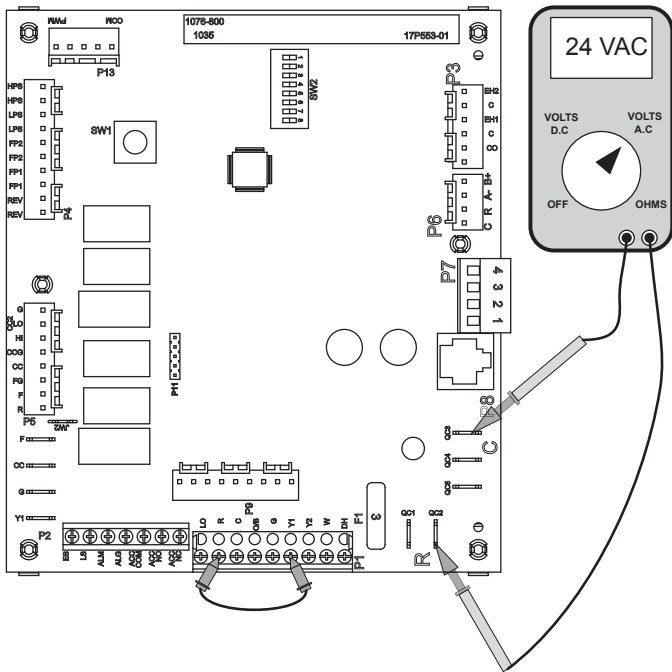

With power applied to the unit connect your Volt meter leads to “R” and “C” on the control board where the yellow and black/white transformer wires connect. The reading should be between 18VAC and 30VAC.

To Check for 24VAC to Compressor Contactor

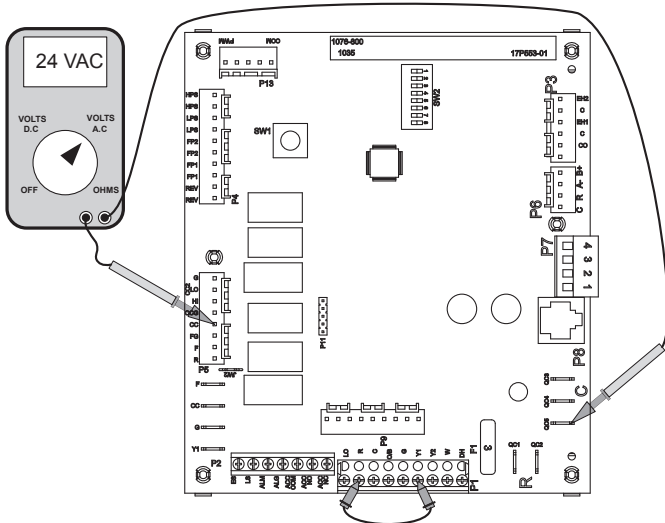

With the AID Tool go to the “Thermostat Inputs” Menu under “Diagnostics” and over-ride the “Y1” input to ON. If an AID Tool is not available remove the P1 connector to disconnect the thermostat from the board and place a jumper wire between “R” and “Y1” as shown. Apply power and put the board into test mode by holding SW1 for 2-5 seconds, the green LED will begin a slow flash. Connect your Volt meter leads to “CC” and “C”. After 1 minute the reading should be between 18 and 30VAC. If you have

a signal and the contactor is not pulled in, check voltage across the contactor coil. If you have voltage across the contractor coil, replace the contactor. If there is no voltage across the contactor coil, verify all wiring between the board and contactor. If you have no voltage between CC and C and the fault LED is not flashing, then replace the board.

To Check Operation of the Reversing Valve Output

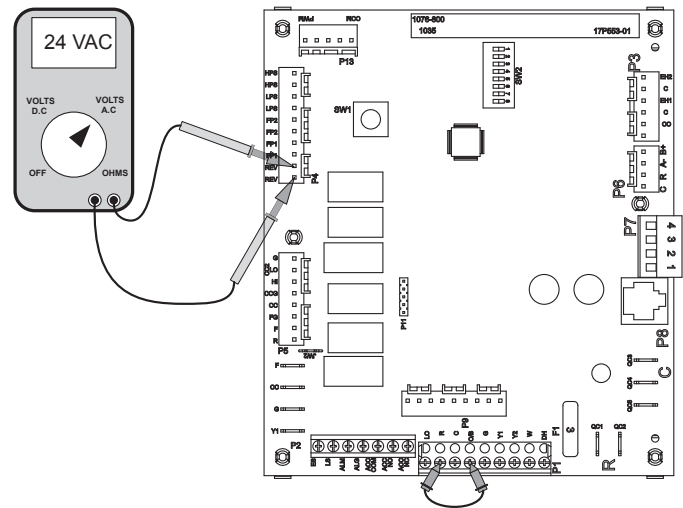

Make sure that SW2-3 is set to “ON”. With the AID Tool go to the “Thermostat Inputs” Menu under “Diagnostics” and over-ride the “O” input to ON. If an AID Tool is not available remove the P1 connector to disconnect the thermostat from the board and place a jumper wire between “R” and “O” as shown. Apply power and put the board into test mode by holding SW1 for 2-5 seconds, the green LED will begin a slow flash. Connect your Volt meter leads to the two “REV” pins on P4. The reading should be between 18 and 30VAC. If you have voltage and the reversing valve is not shifting, check voltage across the coil. If you have voltage across the reversing valve coil, but the valve does not shift the reversing valve coil may be bad. If there is no voltage across the coil, verify all wiring between the board and reversing valve. If no voltage is present on the two REV terminals then replace the board.

Control Board Signals cont.

To Check the Electric Heat Outputs

With the AID Tool go to the “Thermostat Inputs” Menu under “Diagnostics” and over-ride the “W” input to ON. If an AID Tool is not available remove the P1 connector to disconnect the thermostat from the board and place a jumper between “R” and “W” as shown. Put the board into test mode by holding SW1 for 2-5 seconds. The blower will come on and run in high speed. 10 seconds later electric heat output 1 (EH1) will be enabled followed by electric heat output 2 (EH2) in 7.5 seconds. Check EH1 by measuring DC volts between “C” and “EH1” and check EH2 by measuring DC volts between “C” and “EH2”.

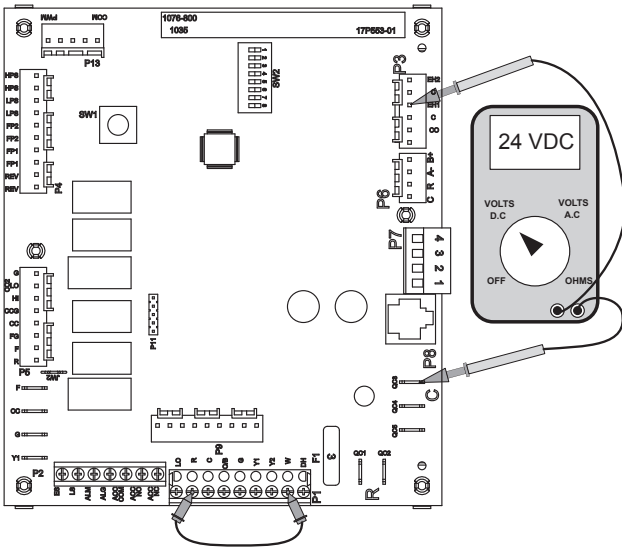

Jumping the Control Board

Stage 1 Heating ABC-A

With the AID Tool go to the “Thermostat Inputs” Menu under “Diagnostics” and over-ride the “Y1” input to ON. If an AID Tool is not available remove the P1 connector to disconnect the thermostat from the board. Place a jumper between the “R” and “Y1” terminals as shown.

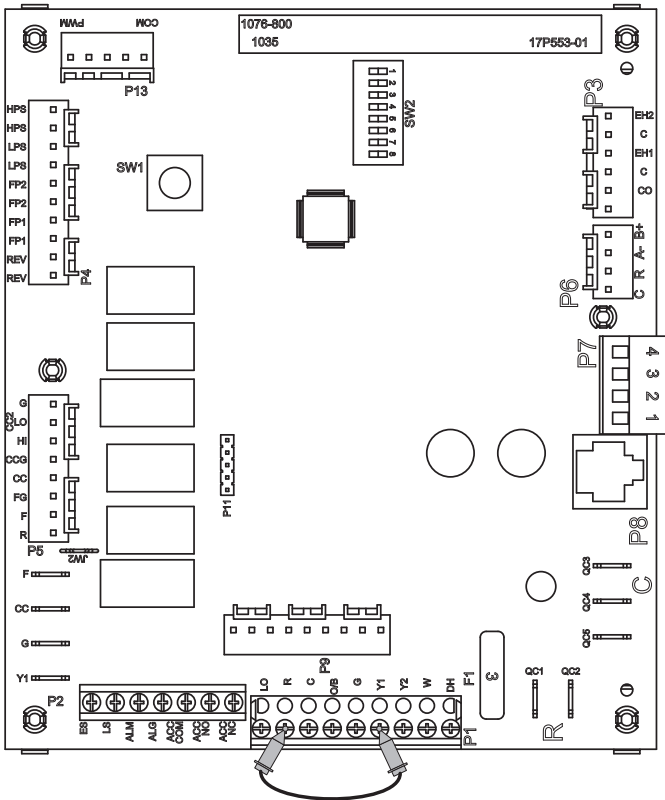

Stage 2 Heating ABC-B

With the AID Tool go to the “Thermostat Inputs” Menu under “Diagnostics” and over-ride the “Y1” input to ON. If an AID Tool is not available remove the P1 connector to disconnect the thermostat from the board. Place a jumper between the “R” and “Y1” terminals as shown.

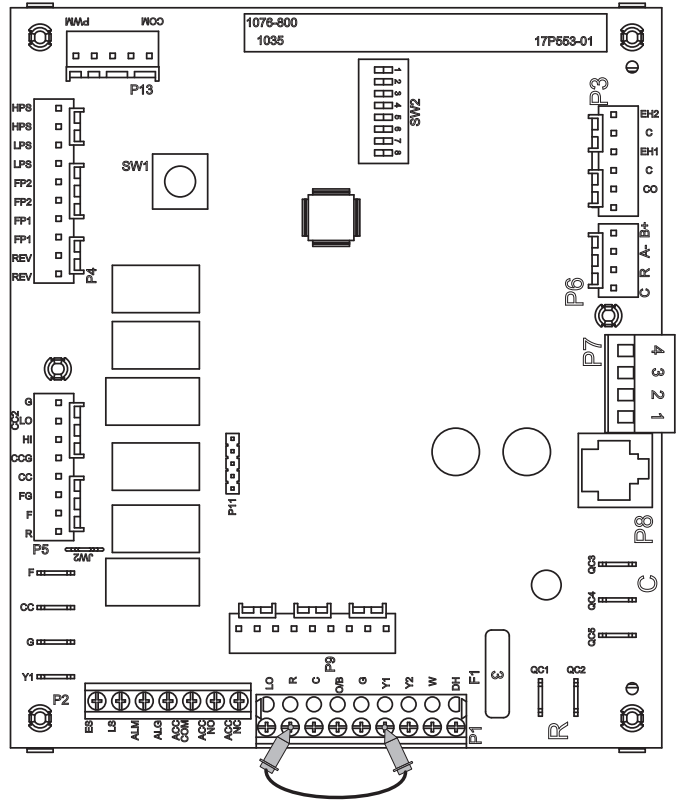

Jumping the Control Board cont.

Stage 1 Cooling ABC-A

With the AID Tool go to the “Thermostat Inputs” Menu under “Diagnostics” and over-ride the “Y1” and “O” inputs to ON. If an AID Tool is not available remove the P1 connector to disconnect the thermostat from the board. Place a jumper between the R, O, and Y1 terminals as shown.

The blower motor will start in “G” blower speed setting immediately, the compressor will start 10 seconds later. If the unit is equipped with an ECM blower motor it will switch to low speed 15 seconds after the Y1 input.

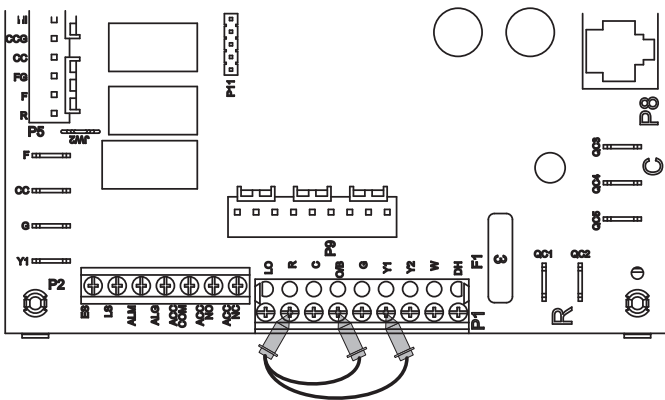

Stage 2 Cooling ABC-B

With the AID Tool go to the “Thermostat Inputs” Menu under “Diagnostics” and over-ride the “Y1” and “O” inputs to ON. If an AID Tool is not available remove the P1 connector to disconnect the thermostat from the board. Place a jumper between the R, O, and Y1 terminals as shown.

The blower motor will start in “G” blower speed setting immediately, the compressor will start 10 seconds later. If the unit is equipped with an ECM blower motor it will switch to low speed 15 seconds after the Y1 input.

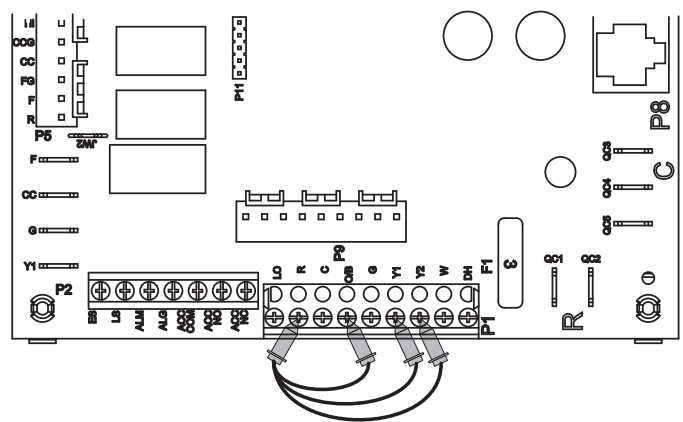

Troubleshooting

Should a major problem develop, refer to the following information for possible causes and corrective steps.

If compressor won't run:

1. The fuse may be open or the circuit breaker is tripped. Check electrical circuits and motor windings for shorts or grounds. Investigate for possible overloading. Replace fuse or reset circuit breakers after fault is corrected.
2. Supply voltage may be too low. Check it with a volt meter.
3. Control system may be faulty. Check control for correct wiring of thermostat or aquastat and check the 24 volt transformer for proper voltage.
4. Wires may be loose or broken. Replace or tighten.
5. The low pressure switch may have tripped due to one or more of the following:
 - a) Heating
 - 1) Plugged heat exchanger on source side
 - 2) Water flow source side - (Low)
 - 3) Water too cold source side
 - 4) Low refrigerant
 - b) Cooling
 - 1) Plugged heat exchanger on load side
 - 2) Water flow load side - (Low)
 - 3) Water too cold load side
 - 4) Low refrigerant
6. The high pressure switch may have tripped due to one or more of the following:
 - a) Heating
 - 1) Plugged heat exchanger on load side
 - 2) Low water flow load side
 - 3) Water too warm load side
 - b) Cooling
 - 1) Plugged heat exchanger on source side
 - 2) Low water flow on source side
 - 3) Water too warm source side
7. The compressor overload protection may be open.
8. The internal winding of the compressor motor may be grounded to the compressor shell. If so, replace the compressor.
9. The compressor winding may be open or shorted. Disconnect power. Check continuity with ohm meter. If the winding is open, replace the compressor.

If sufficient cooling or heating is not obtained:

1. Check control for improper location or setting.
2. Check for restriction in water flow.
3. Check refrigerant subcooling and superheat for proper refrigerant charge and expansion valve operation.
4. The reversing valve may be defective and creating a bypass of refrigerant. If the unit will not heat, check the reversing valve coil.

If the unit operation is noisy:

1. Check compressor for loosened mounting bolts. Make sure compressor is floating free on its isolator mounts. Check for tubing contact with the compressor or other surfaces. Readjust it by bending slightly.
2. Check screws on all panels.
3. Check for chattering or humming in the contactor or relays due to low voltage or a defective holding coil. Replace the component.
4. Check for proper installation of vibration absorbing material under the unit.
5. Check for abnormally high discharge pressures.
6. Compressor rotation incorrect

Troubleshooting cont.

Heating Cycle Analysis

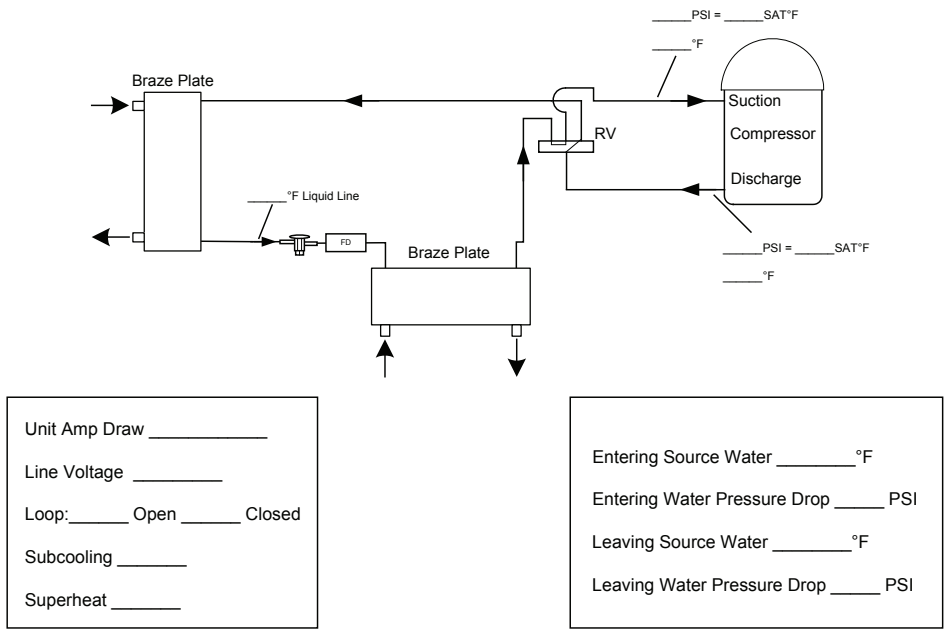

NOTE: Do not attach refrigerant gauges unless a problem is suspected!

Cooling Cycle Analysis

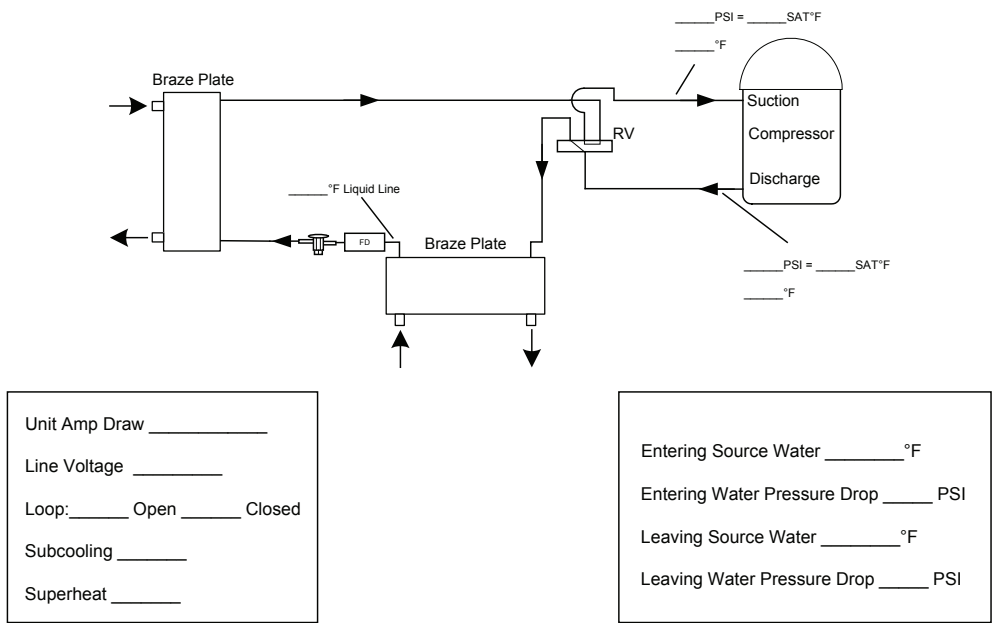

NOTE: Do not attach refrigerant gauges unless a problem is suspected!

Troubleshooting Form

Company Name: _____ Company Phone No: _____
 Technician Name: _____ Date: _____
 Model No: _____ Serial No: _____
 Owner's Name: _____ Open or Closed Loop: _____
 Installation Address: _____ Installation Date: _____

Check One

Start up/Check-out for new installation Troubleshooting Problem: _____

1. FLOW RATE IN GPM (SOURCE SIDE HEAT EXCHANGER)

Water In Pressure: a. _____ PSI
 Water Out Pressure: b. _____ PSI
 Pressure Drop = a - b c. _____ PSI
 Convert Pressure Drop to Flow Rate
 (refer to *Pressure Drop* table) d. _____ GPM

2. TEMPERATURE RISE OR DROP ACROSS SOURCE SIDE HEAT EXCHANGER

	COOLING	HEATING
Water In Temperature:	e. _____ °F	e. _____ °F
Water Out Temperature:	f. _____ °F	f. _____ °F
Temperature Difference:	g. _____ °F	g. _____ °F

3. TEMPERATURE RISE OR DROP ACROSS LOAD SIDE HEAT EXCHANGER

	COOLING	HEATING
Water In Temperature:	h. _____ °F	h. _____ °F
Water Out Temperature:	i. _____ °F	i. _____ °F
Temperature Difference:	j. _____ °F	j. _____ °F

4. HEAT OF REJECTION (HR) / HEAT OF EXTRACTION (HE) CALCULATION

HR or HE = Flow Rate x Temperature Difference x Brine Factor*
 d. (above) x g. (above) x 485 for Methanol or Environol, 500 for water*
 Heat of Extraction (Heating Mode) = _____ btu/hr
 Heat of Rejection (Cooling Mode) = _____ btu/hr
 Compare results to Capacity Data Tables

Note: Steps 5 through 8 need only be completed if a problem is suspected

5. WATTS

	COOLING	HEATING	HYDRONIC
Volts:	m. _____ VOLTS	m. _____ VOLTS	m. _____ VOLTS
Total Amps (Comp. + Fan):	n. _____ AMPS	n. _____ AMPS	n. _____ AMPS
Watts = m. x n. x 0.85	o. _____ WATTS	o. _____ WATTS	o. _____ WATTS

6. CAPACITY

Cooling Capacity = HR. - (o. x 3.413) p. _____ btu/hr
 Heating Capacity = HE. + (o. x 3.413) p. _____ btu/hr

7. EFFICIENCY

Cooling EER = p. / o. q. _____ EER
 Heating COP = p. / (o. x 3.413) q. _____ COP

8. SUPERHEAT (S.H.) / SUBCOOLING (S.C.)

	COOLING	HEATING	HYDRONIC
Suction Pressure:	r. _____ PSI	r. _____ PSI	r. _____ PSI
Suction Saturation Temperature:	s. _____ °F	s. _____ °F	s. _____ °F
Suction Line Temperature:	t. _____ °F	t. _____ °F	t. _____ °F
Superheat = t. - s.	u. _____ °F	u. _____ °F	u. _____ °F
Head Pressure:	v. _____ PSI	v. _____ PSI	v. _____ PSI
High Pressure Saturation Temp.:	w. _____ °F	w. _____ °F	w. _____ °F
Liquid Line Temperature*:	x. _____ °F	x. _____ °F	x. _____ °F
Subcooling = w. - x.	y. _____ °F	y. _____ °F	y. _____ °F

* Note: Liquid line is between the source heat exchanger and the expansion valve in the cooling mode; between the load heat exchanger and the expansion valve in the heating mode.

Performance Data

120 Heating

Source		Load Flow-18 GPM							Load Flow-28 GPM						Load Flow-36 GPM						
EST	Flow	ELT	LLT	HC	Power	HE	COP	LST	LLT	HC	Power	HE	COP	LST	LLT	HC	Power	HE	COP	LST	
° F	GPM	° F	° F	MBTUH	kW	MBTUH		° F	° F	MBTUH	kW	MBTUH		° F	° F	MBTUH	kW	MBTUH		° F	
30	28	60	71.2	97.4	5.4	79.1	5.33	23.3	77.0	101.1	5.38	82.7	5.51	23.0	82.8	104.7	5.4	86.3	5.68	22.7	
		80	90.9	95.1	7.5	69.6	3.73	24.1	88.4	98.7	7.34	73.6	3.94	23.8	85.9	102.3	7.2	77.6	4.15	23.5	
		100	110.6	92.7	9.6	60.0	2.84	24.9	108.2	96.3	9.31	64.5	3.03	24.5	105.7	99.8	9.0	69.0	3.24	24.2	
		120	130.4	90.4	11.7	50.5	2.26	25.7	128.0	93.9	11.28	55.4	2.44	25.3	125.6	97.4	10.9	60.3	2.63	24.9	
	36	60	71.6	101.2	5.40	82.8	5.49	25.3	68.9	105.5	5.41	87.1	5.72	25.0	66.3	109.8	5.41	91.3	5.95	24.8	
		80	91.2	97.9	7.50	72.3	3.82	25.9	88.7	102.3	7.39	77.1	4.06	25.6	86.1	106.7	7.27	81.9	4.30	25.3	
		100	110.8	94.5	9.60	61.8	2.89	26.5	108.4	99.1	9.37	67.1	3.10	26.2	105.9	103.6	9.14	72.4	3.32	25.9	
		120	130.4	91.2	11.70	51.3	2.28	27.1	128.1	95.9	11.35	57.1	2.48	26.7	125.8	100.5	11.00	63.0	2.68	26.4	
50	18	60	72.8	112.2	5.5	93.3	5.91	39.3	78.2	115.9	5.59	96.8	6.04	38.9	83.6	119.6	5.6	100.4	6.18	38.5	
		80	92.6	110.2	7.5	84.5	4.30	40.3	89.7	113.7	7.46	88.2	4.45	39.9	86.7	117.3	7.4	91.9	4.61	39.5	
		100	112.4	108.2	9.5	75.8	3.35	41.3	109.5	111.5	9.33	79.7	3.50	40.9	106.6	114.9	9.2	83.5	3.65	40.4	
		120	132.2	106.2	11.4	67.1	2.73	42.3	129.3	109.4	11.21	71.1	2.86	41.9	126.4	112.6	11.0	75.1	2.99	41.4	
	28	60	73.5	118.2	5.6	99.0	6.15	41.7	74.6	122.7	5.62	103.6	6.40	41.3	75.7	127.3	5.6	108.1	6.65	40.9	
		80	93.3	115.7	7.6	89.8	4.47	42.4	90.2	120.2	7.53	94.5	4.68	42.1	87.1	124.7	7.5	99.2	4.89	41.7	
		100	113.0	113.2	9.5	80.7	3.48	43.2	110.0	117.7	9.43	85.5	3.66	42.8	107.0	122.1	9.3	90.3	3.84	42.4	
		120	132.7	110.7	11.5	71.5	2.82	44.0	129.8	115.1	11.34	76.4	2.98	43.6	126.8	119.5	11.2	81.3	3.13	43.2	
	36	60	74.2	124.3	5.7	104.7	6.32	44.0	71.0	129.6	5.65	110.3	6.69	43.7	67.7	135.0	5.6	115.9	7.05	43.4	
		80	93.9	121.3	7.7	95.1	4.62	44.6	90.7	126.7	7.59	100.8	4.87	44.2	87.6	132.1	7.5	106.5	5.12	43.9	
		100	113.5	118.3	9.6	85.5	3.61	45.1	110.5	123.8	9.53	91.3	3.80	44.8	107.4	129.3	9.5	97.0	3.98	44.4	
		120	133.2	115.3	11.5	75.9	2.94	45.7	130.2	120.9	11.47	81.8	3.08	45.3	127.2	126.5	11.4	87.6	3.23	45.0	
70	18	60	75.0	130.7	5.77	111.0	6.64	57.3	71.5	135.2	5.83	115.3	6.80	56.8	68.0	139.6	5.88	119.5	6.96	56.3	
		80	94.7	128.0	7.57	102.2	4.96	58.3	91.2	132.4	7.62	106.4	5.09	57.8	87.8	136.7	7.67	110.5	5.22	57.3	
		100	114.4	125.4	9.37	93.4	3.92	59.3	111.0	129.6	9.42	97.4	4.03	58.8	107.7	133.8	9.46	101.5	4.14	58.4	
		120	134.1	122.7	11.17	84.6	3.22	60.3	130.8	126.8	11.21	88.5	3.31	59.9	127.5	130.9	11.25	92.5	3.41	59.4	
	28	60	75.9	139.0	5.9	118.8	6.90	60.0	72.3	144.4	5.86	124.4	7.22	59.6	68.6	149.9	5.8	130.0	7.55	59.1	
		80	95.6	136.4	7.7	110.1	5.19	60.8	92.0	141.7	7.71	115.4	5.39	60.3	88.4	147.1	7.7	120.8	5.59	59.9	
		100	115.3	133.7	9.5	101.3	4.13	61.5	111.8	139.1	9.55	106.5	4.26	61.1	108.3	144.4	9.6	111.6	4.40	60.7	
		120	135.0	131.1	11.3	92.6	3.41	62.3	131.6	136.4	11.40	97.5	3.51	61.9	128.1	141.7	11.5	102.4	3.60	61.5	
	36	60	76.9	147.3	6.04	126.7	7.15	62.7	73.0	153.7	5.90	133.6	7.65	62.3	69.2	160.1	5.75	140.5	8.16	62.0	
		80	96.6	144.7	7.82	118.0	5.42	63.2	92.8	151.1	7.79	124.5	5.68	62.9	89.0	157.6	7.77	131.1	5.94	62.5	
		100	116.3	142.0	9.60	109.3	4.33	63.7	112.6	148.5	9.69	115.5	4.49	63.4	108.9	155.0	9.78	121.6	4.64	63.0	
		120	136.0	139.4	11.38	100.6	3.59	64.2	132.4	146.0	11.59	106.4	3.69	63.9	128.7	152.5	11.80	112.2	3.79	63.6	
90	18	60	77.0	148.1	6.00	127.6	7.23	75.4	73.1	154.6	6.05	133.9	7.48	74.7	69.2	161.0	6.10	140.2	7.73	73.9	
		80	96.7	145.5	8.00	118.2	5.33	76.5	92.9	152.1	8.05	124.6	5.53	75.7	89.1	158.7	8.10	131.1	5.74	75.0	
		100																			
		120	Operation not recommended																		
	28	60	78.3	159.9	6.1	138.9	7.63	78.4	74.1	166.4	6.18	145.3	7.88	77.8	69.9	172.9	6.2	151.7	8.14	77.3	
		80	98.0	157.2	8.0	130.0	5.78	79.2	93.9	163.9	8.05	136.4	5.96	78.6	89.8	170.6	8.1	142.8	6.15	78.1	
		100																			
		120	Operation not recommended																		
	36	60	79.7	171.6	6.28	150.2	8.01	81.4	75.1	178.2	6.32	156.6	8.27	81.0	70.6	184.8	6.35	163.1	8.53	80.7	
		80	99.4	169.0	7.95	141.8	6.23	81.9	94.9	175.7	8.06	148.2	6.39	81.5	90.4	182.4	8.16	154.5	6.55	81.2	
		100																			
		120	Operation not recommended																		

EST = entering source fluid temperature to heat pump
 HC = total heating capacity in MBTUH
 ELT = entering load fluid temperature to heat pump
 HE = heat extracted in MBTUH
 LST = leaving source fluid temperature from heat pump
 COP = coefficient of performance
 LLT = leaving load fluid temperature from heat pump

Performance Data cont.

120 Cooling

Source		Load Flow-18 GPM							Load Flow-28 GPM							Load Flow-36 GPM						
EST	Flow	ELT	LLT	TC	Power	HR	EER	LST	LLT	TC	Power	HR	EER	LST	LLT	TC	Power	HR	EER	LST		
° F	GPM	° F	° F	MBTUH	kW	MBTUH		° F	° F	MBTUH	kW	MBTUH		° F	° F	MBTUH	kW	MBTUH		° F		
30	18	50	35.9	123.0	5.21	140.8	23.61	46.1	39.2	127.1	5.26	145.1	24.16	46.6	42.5	131.2	5.31	149.3	24.71	47.1		
		70	54.1	138.7	5.39	157.1	25.73	48.0	57.8	143.3	5.44	161.9	26.36	48.5	61.5	147.9	5.48	166.6	26.98	49.1		
		90	72.3	154.4	5.57	173.4	27.72	49.9	76.4	159.5	5.61	178.7	28.42	50.5	80.6	164.7	5.66	184.0	29.11	51.1		
		110	90.5	170.1	5.75	189.7	29.58	51.7	95.1	175.8	5.79	195.5	30.35	52.4	99.6	181.4	5.83	201.3	31.11	53.1		
	28	50	35.5	126.2	5.01	143.3	25.19	42.2	38.9	130.3	5.06	147.5	25.75	42.6	42.3	134.4	5.11	151.8	26.29	43.0		
		70	53.7	142.3	5.15	159.9	27.66	43.7	57.5	147.0	5.20	164.7	28.29	44.1	61.3	151.7	5.25	169.6	28.90	44.5		
		90	71.8	158.5	5.28	176.5	29.99	45.1	76.1	163.7	5.33	181.9	30.70	45.5	80.3	169.0	5.38	187.3	31.38	46.0		
		110	90.0	174.6	5.42	193.1	32.21	46.5	94.7	180.4	5.47	199.1	32.98	47.0	99.3	186.3	5.52	205.1	33.74	47.5		
	36	50	35.2	129.4	4.81	145.8	26.90	38.4	38.7	133.5	4.86	150.0	27.45	38.6	42.1	137.5	4.91	154.3	28.00	38.8		
		70	53.3	146.0	4.90	162.7	29.77	39.3	57.2	150.7	4.96	167.6	30.39	39.6	61.1	155.4	5.01	172.5	31.01	39.9		
		90	71.4	162.5	5.00	179.6	32.53	40.3	75.7	167.9	5.05	185.1	33.21	40.6	80.1	173.2	5.11	190.7	33.90	40.9		
		110	89.5	179.1	5.09	196.5	35.19	41.3	94.3	185.1	5.15	202.7	35.93	41.6	99.1	191.1	5.21	208.9	36.68	42.0		
50	18	50	36.9	114.6	5.96	134.9	19.72	65.5	39.9	119.5	6.02	140.1	20.34	66.0	42.9	124.5	6.07	145.2	20.97	66.6		
		70	55.1	130.1	6.41	152.0	21.05	67.4	58.5	135.3	6.46	157.3	21.69	68.0	62.0	140.4	6.51	162.6	22.32	68.6		
		90	73.3	145.7	6.86	169.1	22.27	69.4	77.2	151.0	6.90	174.6	22.92	70.0	81.0	156.4	6.94	180.1	23.56	70.6		
		110	91.5	161.2	7.31	186.1	23.39	71.3	95.8	166.8	7.34	191.9	24.05	72.0	100.1	172.4	7.38	197.6	24.72	72.6		
	28	50	36.4	118.5	6.10	139.3	19.41	61.8	39.6	122.8	6.15	143.8	19.96	62.2	42.7	127.2	6.21	148.4	20.50	62.7		
		70	54.6	134.6	6.38	156.4	21.11	63.3	58.2	139.4	6.43	161.3	21.69	63.7	61.7	144.2	6.47	166.3	22.27	64.2		
		90	72.7	150.8	6.65	173.5	22.67	64.8	76.7	156.0	6.70	178.8	23.29	65.2	80.8	161.1	6.74	184.1	23.90	65.7		
		110	90.9	167.0	6.93	190.6	24.10	66.2	95.3	172.5	6.97	196.3	24.75	66.7	99.8	178.1	7.01	202.0	25.40	67.2		
	36	50	36.0	122.3	6.25	143.6	20.95	58.2	39.3	126.1	6.29	147.6	21.41	58.5	42.6	130.0	6.34	151.6	21.88	58.7		
		70	54.1	139.1	6.35	160.8	23.37	59.2	57.8	143.5	6.40	165.3	23.90	59.5	61.5	147.9	6.44	169.9	24.42	59.7		
		90	72.1	155.9	6.45	177.9	25.72	60.2	76.3	160.9	6.50	183.1	26.30	60.5	80.5	165.9	6.55	188.2	26.88	60.8		
		110	90.2	172.8	6.55	195.1	27.98	61.2	94.8	178.3	6.60	200.8	28.61	61.5	99.5	183.8	6.65	206.5	29.25	61.8		
70	18	50	37.8	106.2	6.71	129.1	15.83	84.8	40.5	112.0	6.77	135.1	16.53	85.5	43.3	117.7	6.83	141.0	17.23	86.2		
		70	56.1	121.6	7.43	146.9	16.37	86.8	59.2	127.3	7.48	152.8	17.02	87.5	62.4	132.9	7.53	158.6	17.66	88.2		
		90	74.3	136.9	8.14	164.7	16.82	88.9	77.9	142.6	8.18	170.5	17.42	89.5	81.5	148.2	8.22	176.2	18.02	90.2		
		110	Operation not recommended																			
	28	50	37.3	110.7	7.20	135.3	15.39	81.4	40.2	115.4	7.25	140.1	15.92	81.9	43.1	120.1	7.30	145.0	16.45	82.3		
		70	55.5	126.9	7.61	152.9	16.68	83.0	58.8	131.8	7.66	157.9	17.22	83.4	62.2	136.7	7.70	163.0	17.75	83.9		
		90	73.6	143.1	8.02	170.5	17.84	84.5	77.4	148.2	8.06	175.7	18.38	84.9	81.2	153.3	8.10	181.0	18.92	85.4		
		110	Operation not recommended																			
	36	50	36.8	115.2	7.68	141.4	15.00	78.1	39.9	118.8	7.73	145.2	15.38	78.3	43.0	122.4	7.77	148.9	15.75	78.5		
		70	54.8	132.3	7.79	158.9	16.98	79.1	58.4	136.4	7.83	163.1	17.40	79.3	62.0	140.4	7.88	167.3	17.83	79.6		
		90	72.9	149.3	7.90	176.3	18.90	80.1	76.9	153.9	7.94	181.0	19.38	80.4	80.9	158.5	7.98	185.7	19.85	80.6		
		110	Operation not recommended																			
90	18	50	38.7	98.5	9.02	129.3	11.92	104.8	41.3	102.7	9.09	133.7	12.36	105.3	43.9	107.0	9.16	138.2	12.81	105.8		
		70	57.0	113.8	9.47	146.1	12.79	106.7	60.0	118.2	9.52	150.7	13.23	107.3	63.0	122.7	9.57	155.3	13.67	107.8		
		90	75.2	129.1	9.92	162.9	13.59	108.7	78.6	133.7	9.96	167.7	14.03	109.2	82.1	138.4	9.99	172.4	14.48	109.8		
		110	Operation not recommended																			
	28	50	38.2	103.4	9.05	134.3	11.43	101.4	40.9	107.3	9.10	138.4	11.78	101.8	43.6	111.2	9.16	142.5	12.14	102.1		
		70	56.3	119.4	14.33	168.4	8.33	103.8	59.5	123.7	11.88	164.3	10.41	103.7	62.7	128.0	9.43	160.2	13.57	103.6		
		90	74.5	135.5	19.61	202.5	6.91	106.3	78.1	140.2	14.66	190.2	9.56	105.7	81.7	144.8	9.71	177.9	14.92	105.1		
		110	Operation not recommended																			
	36	50	37.6	108.3	9.08	139.2	12.34	98.0	40.5	111.9	9.12	143.0	12.68	98.2	43.4	115.5	9.17	146.7	13.01	98.4		
		70	55.7	125.1	19.19	190.6	10.42	100.9	59.0	129.2	14.24	177.8	12.61	100.2	62.4	133.4	9.29	165.1	14.81	99.5		
		90	73.7	142.0	29.31	242.0	10.78	103.9	77.5	146.6	19.36	212.7	13.67	102.2	81.3	151.3	9.42	183.4	16.56	100.5		
		110	Operation not recommended																			
110	18	50	39.6	90.8	11.33	129.5	8.01	124.8	42.0	93.5	11.41	132.4	8.20	125.2	44.5	96.2	11.48	135.4	8.38	125.5		
		70	57.9	106.0	11.52	145.3	9.20	126.6	60.7	109.2	11.57	148.7	9.44	127.0	63.6	112.4	11.62	152.0	9.67	127.4		
		90	Operation not recommended																			
		110	Operation not recommended																			
	28	50	39.0	96.1	10.90	133.3	8.81	121.3	41.6	99.2	10.96	136.6	9.05	121.6	44.1	102.4	11.02	140.0	9.29	121.9		
		70	57.2	112.0	21.05	183.8	5.32	124.7	60.2	115.6	16.11	170.6	7.18	124.0	63.2	119.3	11.16	157.4	10.69	123.4		
		90	Operation not recommended																			
		110	Operation not recommended																			
	36	50	38.4	101.3	10.47	137.0	9.68	117.8	41.1	104.9	10.52	140.8	9.97	118.1	43.8	108.5	10.56	144.5	10.27	118.3		
		70	56.5	117.9	30.59	222.3	3.86	122.7	59.6	122.1	20.65	192.6	7.82	121.0	62.8	126.3	10.71	162.8	11.79	119.3		
		90	Operation not recommended																			
		110	Operation not recommended																			

EST = entering source fluid temperature to heat pump
 TC = total cooling capacity in MBTUH
 ELT = entering load fluid temperature to heat pump
 HR = heat rejected in MBTUH
 LST = leaving source fluid temperature from heat pump
 EER = energy efficiency ratio
 LLT = leaving load fluid temperature from heat pump

Performance Data cont.

180 Heating

Source		Load Flow-24 GPM							Load Flow-36 GPM							Load Flow-48 GPM						
EST	Flow	ELT	LLT	HC	Power	HE	COP	LST	LLT	HC	Power	HE	COP	LST	LLT	HC	Power	HE	COP	LST		
° F	GPM	° F	° F	MBTUH	kW	MBTUH		° F	° F	MBTUH	kW	MBTUH		° F	° F	MBTUH	kW	MBTUH		° F		
30	36	60	72.3	143.6	8.9	113.4	4.75	22.8	69.4	144.7	8.65	115.2	4.90	22.7	66.4	145.9	8.5	117.0	5.06	22.6		
		80	91.7	135.6	11.2	97.5	3.56	23.8	88.8	137.2	11.01	99.6	3.65	23.7	86.0	138.8	10.9	101.8	3.75	23.5		
		100	111.0	127.7	13.5	81.6	2.77	24.8	108.3	129.7	13.37	84.1	2.84	24.6	105.7	131.7	13.3	86.5	2.91	24.5		
		120	130.3	119.7	15.8	65.8	2.22	25.8	127.8	122.2	15.73	68.5	2.28	25.6	125.4	124.7	15.7	71.2	2.33	25.5		
	48	60	72.8	148.6	8.90	118.2	4.89	24.9	69.6	150.0	8.70	120.3	5.05	24.8	66.5	151.3	8.50	122.3	5.22	24.7		
		80	92.0	139.6	11.23	101.2	3.64	25.7	89.1	141.5	11.07	103.7	3.75	25.5	86.2	143.3	10.90	106.1	3.85	25.4		
		100	111.2	130.5	13.57	84.2	2.82	26.4	108.5	133.0	13.43	87.1	2.90	26.3	105.8	135.4	13.30	90.0	2.98	26.1		
		120	130.4	121.5	15.90	67.2	2.24	27.1	128.0	124.5	15.80	70.5	2.31	27.0	125.5	127.4	15.70	73.8	2.38	26.8		
50	24	60	74.5	169.1	9.3	137.5	5.32	38.2	71.1	171.4	9.08	140.5	5.50	37.9	67.7	173.8	8.9	143.4	5.68	37.7		
		80	93.7	159.8	11.8	119.6	3.95	39.7	90.4	162.4	11.63	122.7	4.06	39.5	87.1	164.9	11.5	125.7	4.18	39.2		
		100	112.9	150.5	14.3	101.7	3.07	41.3	109.8	153.3	14.18	104.9	3.15	41.0	106.7	156.1	14.1	108.1	3.23	40.7		
		120	132.1	141.2	16.8	83.9	2.45	42.8	129.2	144.2	16.73	87.1	2.51	42.5	126.3	147.2	16.7	90.4	2.57	42.2		
	36	60	75.0	174.3	9.3	142.6	5.49	40.9	71.4	176.7	9.14	145.5	5.66	40.7	67.8	179.0	9.0	148.4	5.84	40.5		
		80	94.1	164.4	11.8	124.0	4.07	42.1	90.7	167.1	11.68	127.3	4.19	41.9	87.3	169.9	11.5	130.5	4.32	41.7		
		100	113.3	154.5	14.4	105.4	3.15	43.3	110.1	157.6	14.22	109.1	3.25	43.1	106.9	160.7	14.1	112.7	3.35	42.8		
		120	132.4	144.6	16.9	86.9	2.51	44.5	129.5	148.1	16.76	90.8	2.59	44.2	126.5	151.5	16.6	94.8	2.67	44.0		
	48	60	75.4	179.6	9.4	147.6	5.59	43.7	71.7	181.9	9.20	150.5	5.76	43.5	67.9	184.3	9.1	153.4	5.92	43.4		
		80	94.5	169.0	11.9	128.4	4.13	44.5	91.0	171.9	11.73	131.9	4.26	44.3	87.5	174.8	11.6	135.3	4.40	44.2		
		100	113.6	158.5	14.5	109.2	3.19	45.3	110.4	161.9	14.27	113.2	3.30	45.1	107.1	165.3	14.1	117.3	3.42	45.0		
		120	132.7	148.0	17.0	89.9	2.53	46.1	129.7	151.9	16.80	94.6	2.63	45.9	126.7	155.9	16.6	99.2	2.73	45.7		
70	24	60	77.1	199.5	9.70	166.4	6.03	55.7	73.0	203.4	9.55	170.8	6.24	55.3	68.9	207.2	9.40	175.1	6.46	55.0		
		80	96.1	187.8	12.43	145.4	4.43	57.5	92.3	191.7	12.30	149.8	4.57	57.1	88.4	195.6	12.17	154.1	4.71	56.8		
		100	115.1	176.2	15.17	124.4	3.40	59.3	111.5	180.1	15.05	128.8	3.51	58.9	107.9	184.1	14.93	133.1	3.61	58.6		
		120	134.1	164.5	17.90	103.4	2.69	61.1	130.8	168.5	17.80	107.7	2.77	60.7	127.4	172.5	17.70	112.1	2.86	60.4		
	36	60	77.6	205.0	9.8	171.7	6.16	59.0	73.4	208.6	9.63	175.7	6.35	58.8	69.1	212.2	9.5	179.8	6.54	58.5		
		80	96.6	193.2	12.5	150.5	4.53	60.4	92.6	197.0	12.35	154.9	4.67	60.1	88.6	200.9	12.2	159.3	4.83	59.8		
		100	115.6	181.3	15.3	129.3	3.48	61.8	111.9	185.5	15.08	134.0	3.61	61.5	108.1	189.7	14.9	138.8	3.73	61.2		
		120	134.6	169.5	18.0	108.0	2.76	63.1	131.1	173.9	17.80	113.2	2.86	62.8	127.7	178.4	17.6	118.3	2.97	62.5		
	48	60	78.1	210.5	9.80	177.1	6.29	62.4	73.7	213.9	9.70	180.7	6.46	62.2	69.3	217.2	9.60	184.4	6.63	62.1		
		80	97.1	198.5	12.57	155.6	4.63	63.3	93.0	202.4	12.40	160.0	4.78	63.1	88.9	206.2	12.23	164.5	4.94	62.9		
		100	116.0	186.4	15.33	134.1	3.56	64.2	112.2	190.9	15.10	139.3	3.71	64.0	108.4	195.3	14.87	144.5	3.85	63.8		
		120	135.0	174.4	18.10	112.6	2.82	65.2	131.4	179.4	17.80	118.6	2.95	64.9	127.9	184.3	17.50	124.6	3.09	64.6		
90	24	60	79.9	231.6	9.90	197.8	6.85	73.0	75.0	234.4	9.80	201.0	7.01	72.7	70.2	237.2	9.70	204.1	7.16	72.5		
		80	99.0	221.0	12.47	178.5	5.19	74.7	94.4	223.9	12.35	181.8	5.31	74.4	89.7	226.9	12.23	185.1	5.43	74.1		
		100	Operation not recommended																			
		120	Operation not recommended																			
	36	60	80.7	240.6	10.1	206.1	6.98	76.9	75.6	242.7	9.95	208.7	7.15	76.7	70.5	244.8	9.8	211.4	7.32	76.5		
		80	99.8	230.3	12.9	186.2	5.22	78.2	94.9	232.7	12.78	189.1	5.33	78.0	90.1	235.1	12.7	191.9	5.44	77.8		
		100	Operation not recommended																			
		120	Operation not recommended																			
	48	60	81.4	249.6	10.30	214.4	7.10	80.8	76.1	251.0	10.10	216.5	7.29	80.7	70.8	252.4	9.90	218.6	7.47	80.6		
		80	100.6	239.6	13.37	193.9	5.25	81.7	95.5	241.4	13.22	196.3	5.35	81.6	90.5	243.3	13.07	198.7	5.46	81.5		
		100	Operation not recommended																			
		120	Operation not recommended																			

EST = entering source fluid temperature to heat pump
 HC = total heating capacity in MBTUH
 ELT = entering load fluid temperature to heat pump
 HE = heat extracted in MBTUH
 LST = leaving source fluid temperature from heat pump
 COP = coefficient of performance
 LLT = leaving load fluid temperature from heat pump

10/4/24

Performance Data cont.

180 Cooling

Source		Load Flow-24 GPM							Load Flow-36 GPM							Load Flow-48 GPM						
EST	Flow	ELT	LLT	TC	Power	HR	EER	LST	LLT	TC	Power	HR	EER	LST	LLT	TC	Power	HR	EER	LST		
° F	GPM	° F	° F	MBTUH	kW	MBTUH		° F	° F	MBTUH	kW	MBTUH		° F	° F	MBTUH	kW	MBTUH		° F		
30	24	50	37.5	145.3	5.83	165.2	24.92	44.2	40.4	152.0	6.04	172.6	25.15	44.8	43.2	158.6	6.25	179.9	25.38	45.5		
		70	54.3	183.0	6.45	205.0	28.36	47.6	57.9	191.0	6.65	213.6	28.73	48.4	61.5	198.9	6.84	222.3	29.10	49.1		
		90	71.0	220.7	7.08	244.9	31.19	51.0	75.4	230.0	7.25	254.7	31.71	51.9	79.7	239.3	7.42	264.6	32.23	52.7		
		110	87.8	258.4	7.70	284.7	33.56	54.5	92.9	269.0	7.86	295.8	34.23	55.4	98.0	279.6	8.01	306.9	34.91	56.4		
	36	50	36.5	156.7	5.53	175.6	28.34	41.1	39.6	163.6	5.69	183.0	28.77	41.6	42.7	170.5	5.84	190.4	29.19	42.0		
		70	53.3	194.0	6.18	215.1	31.39	43.6	57.1	202.3	6.33	223.9	31.97	44.2	61.0	210.7	6.48	232.8	32.52	44.8		
		90	70.1	231.2	6.83	254.5	33.87	46.2	74.7	241.1	6.97	264.9	34.58	46.8	79.2	250.9	7.12	275.2	35.25	47.5		
		110	86.9	268.5	7.48	294.0	35.92	48.7	92.2	279.8	7.62	305.8	36.74	49.5	97.5	291.1	7.76	317.6	37.54	50.2		
	48	50	35.6	168.1	5.23	185.9	32.14	38.0	38.9	175.2	5.33	193.4	32.86	38.3	42.2	182.3	5.43	200.8	33.57	38.6		
		70	52.4	204.9	5.90	225.1	34.71	39.7	56.4	213.7	6.01	234.2	35.53	40.1	60.4	222.4	6.12	243.3	36.34	40.5		
		90	69.2	241.8	6.58	264.2	36.76	41.3	74.0	252.1	6.69	275.0	37.65	41.8	78.7	262.5	6.81	285.7	38.55	42.3		
		110	86.1	278.6	7.25	303.3	38.43	43.0	91.5	290.6	7.38	315.8	39.39	43.6	97.0	302.6	7.50	328.2	40.35	44.1		
50	24	50	38.5	134.1	7.77	160.6	18.80	63.8	41.1	140.7	7.97	167.9	19.11	64.4	43.7	147.3	8.18	175.2	19.42	65.0		
		70	55.7	166.7	8.55	195.9	21.24	66.8	58.9	174.2	8.77	204.1	21.59	67.5	62.2	181.7	8.99	212.4	21.93	68.2		
		90	72.9	199.4	9.34	231.2	23.26	69.9	76.8	207.8	9.57	240.4	23.65	70.7	80.7	216.2	9.80	249.6	24.04	71.4		
		110	90.1	232.0	10.13	266.6	24.96	72.9	94.7	241.3	10.37	276.7	25.40	73.8	99.2	250.6	10.61	286.8	25.84	74.6		
	36	50	37.7	143.4	7.42	168.7	19.34	60.7	40.5	150.2	7.59	176.1	19.78	61.2	43.3	157.0	7.77	183.6	20.20	61.6		
		70	54.8	177.4	8.23	205.5	21.55	63.0	58.2	185.1	8.41	213.8	22.00	63.6	61.7	192.7	8.60	222.1	22.42	64.1		
		90	71.8	211.5	9.05	242.4	23.37	65.4	76.0	219.9	9.23	251.5	23.82	66.0	80.2	228.4	9.42	260.6	24.25	66.6		
		110	88.9	245.5	9.87	279.2	24.89	67.7	93.8	254.8	10.05	289.1	25.35	68.4	98.7	264.1	10.24	299.1	25.78	69.0		
	48	50	36.9	152.7	7.07	176.8	23.78	57.6	39.9	159.7	7.22	184.4	24.35	57.9	42.8	166.8	7.37	192.0	24.91	58.2		
		70	53.8	188.1	7.91	215.1	25.99	59.2	57.5	195.9	8.06	223.4	26.58	59.6	61.2	203.7	8.21	231.7	27.16	60.0		
		90	70.8	223.6	8.76	253.5	27.77	60.9	75.2	232.1	8.90	262.5	28.38	61.3	79.7	240.7	9.04	271.5	28.98	61.7		
		110	87.7	259.1	9.60	291.8	29.23	62.5	92.9	268.3	9.74	301.6	29.86	63.0	98.1	277.6	9.88	311.3	30.48	63.4		
70	24	50	39.4	122.9	9.70	156.0	12.67	83.4	41.8	129.4	9.90	163.2	13.06	84.0	44.2	135.9	10.10	170.4	13.46	84.6		
		70	57.1	150.5	10.65	186.8	14.12	86.1	60.0	157.5	10.90	194.7	14.45	86.7	62.9	164.5	11.14	202.5	14.77	87.4		
		90	74.7	178.0	11.61	217.6	15.34	88.7	78.2	185.5	11.89	226.1	15.60	89.4	81.7	193.0	12.17	234.6	15.86	90.2		
		110	Operation not recommended																			
	36	50	38.8	130.1	9.30	161.8	13.98	80.3	41.3	136.8	9.50	169.3	14.40	80.8	43.8	143.6	9.71	176.7	14.80	81.3		
		70	56.2	160.9	10.29	196.0	15.64	82.4	59.3	167.8	10.50	203.7	15.98	82.9	62.5	174.8	10.71	211.3	16.31	83.4		
		90	73.5	191.7	11.27	230.2	17.01	84.6	77.3	198.8	11.50	238.1	17.30	85.1	81.2	205.9	11.72	245.9	17.57	85.6		
		110	Operation not recommended																			
	48	50	38.2	137.2	8.90	167.6	15.42	77.2	40.9	144.3	9.11	175.3	15.83	77.5	43.5	151.3	9.31	183.1	16.25	77.9		
		70	55.3	171.3	9.92	205.1	17.27	78.8	58.7	178.2	10.10	212.7	17.63	79.1	62.1	185.1	10.29	220.2	17.99	79.5		
		90	72.4	205.4	10.93	242.7	18.79	80.4	76.5	212.1	11.10	250.0	19.10	80.7	80.6	218.8	11.27	257.3	19.42	81.1		
		110	Operation not recommended																			
90	24	50	40.3	113.4	11.67	153.2	10.14	103.2	42.4	119.3	11.92	160.0	10.45	103.7	44.6	125.3	12.17	166.8	10.76	104.3		
		70	58.1	138.3	12.64	181.4	11.37	105.6	60.8	144.5	12.91	188.6	11.63	106.2	63.5	150.7	13.18	195.7	11.88	106.8		
		90	76.0	163.2	13.60	209.6	12.42	108.0	79.2	169.7	13.90	217.1	12.63	108.7	82.4	176.2	14.20	224.6	12.84	109.3		
		110	Operation not recommended																			
	36	50	39.6	120.6	11.17	158.7	10.79	100.1	42.0	126.8	11.39	165.7	11.13	100.6	44.3	133.0	11.61	172.6	11.46	101.0		
		70	57.3	147.5	12.22	189.2	12.07	102.0	60.2	153.9	12.46	196.4	12.35	102.5	63.1	160.2	12.71	203.6	12.61	102.9		
		90	75.0	174.5	13.27	219.8	13.15	103.9	78.5	181.0	13.54	227.2	13.37	104.4	81.9	187.4	13.80	234.5	13.58	104.9		
		110	Operation not recommended																			
	48	50	39.0	127.8	10.68	164.2	12.46	97.1	41.5	134.3	10.87	171.3	12.84	97.4	44.0	140.8	11.06	178.5	13.21	97.7		
		70	56.5	156.8	11.81	197.1	13.83	98.5	59.6	163.3	12.02	204.3	14.14	98.8	62.7	169.7	12.23	211.5	14.44	99.1		
		90	74.0	185.8	12.94	230.0	14.95	99.9	77.8	192.3	13.17	237.2	15.21	100.2	81.5	198.7	13.40	244.5	15.46	100.5		
		110	Operation not recommended																			
110	24	50	41.1	103.8	13.64	150.4	7.61	122.9	43.1	109.3	13.94	156.8	7.84	123.5	45.1	114.7	14.23	163.3	8.06	124.0		
		70	59.2	126.1	14.62	176.0	8.62	125.1	61.6	131.5	14.93	182.5	8.81	125.7	64.1	137.0	15.23	189.0	9.00	126.2		
		90	Operation not recommended																			
		110	Operation not recommended																			
	36	50	40.5	111.1	13.05	155.6	8.51	119.9	42.6	116.8	13.28	162.1	8.79	120.3	44.7	122.5	13.52	168.6	9.06	120.7		
		70	58.5	134.2	14.16	182.5	9.48	121.6	61.1	139.9	14.43	189.2	9.70	122.0	63.7	145.7	14.70	195.9	9.91	122.5		
		90	Operation not recommended																			
		110	Operation not recommended																			
	48	50	39.8	118.3	12.45	160.8	9.50	116.9	42.1	124.3	12.63	167.3	9.84	117.2	44.4	130.2	12.80	173.9	10.17	117.5		
		70	57.8	142.3	13.70	189.0	10.38	118.1	60.6	148.3	13.93	195.9	10.64	118.4	63.4	154.4	14.17	202.8	10.90	118.7		
		90	Operation not recommended																			
		110	Operation not recommended																			

EST = entering source fluid temperature to heat pump
 TC = total cooling capacity in MBTUH
 ELT = entering load fluid temperature to heat pump
 HR = heat rejected in MBTUH
 LST = leaving source fluid temperature from heat pump
 EER = energy efficiency ratio
 LLT = leaving load fluid temperature from heat pump

Service Parts List

Part Description		120				180			
		208-230/60/3	208-230/60/3	460/60/3	575/60/3	208-230/60/3	208-230/60/3	460/60/3	575/60/3
Refrigeration Components	Compressor	34P772-01	34P772-03	34P772-04	34P772-05	34P793-01	34P802-03	34P802-04	34P802-05
	Compressor Sound Jacket	92P504A03				92P504A03			
	Thermal Expansion Valve	33P605-29				33P605-30			
	Filter Dryer	36P500B02				36P500B02			
	Reversing Valve with Coil	33P526-05				33P526-05			
	Brazed Plate Heat Exchanger	62P642-01				62P642-01			
	Heat Exchanger Support Bracket	47F588-01				47F588-01			
Safeties / Sensors	High Pressure Switch	SKHPE600				SKHPE600			
	Low Pressure Switch	SKLPE40				SKLPE40			
	Water Temperature Sensor	12P541-01				12P541-01			
	Refrigerant Temp Sensor	12P564-08				12P564-08			
Electrical	Compressor Contactor	13P521-01	13P522-01			13P521-01	13P522-01		
	Transformer	15P501B01		15P505B01	15P506B01	15P501B01		15P505B01	15P506B01
	Power In Terminal Block	12P524A01				12P524A01			
	Connection Block - Small	12P503-06				12P503-06			
	Grounding Lug	12P004A				12P004A			
Control	ABC Board	17X553-12				17X553-12			
	AXB Board	17X557-14				17X557-14			
	24 DC Power Supply Board	17P568-02				17P568-02			
	HMI	19X641-13				19X641-13			
	HydroLink Controller	17X567-01				17X567-01			

Decommissioning

Before carrying out this procedure, it is essential that the technician is completely familiar with the equipment and all its detail. It is recommended good practice that all refrigerants are recovered safely. Prior to the task being carried out, an oil and refrigerant sample shall be taken in case analysis is required prior to re-use of recovered refrigerant. It is essential that electrical power is available before the task is commenced.

1. Become familiar with the equipment and its operation.
2. Isolate system electrically.
3. Before attempting the procedure, ensure that:
 - mechanical handling equipment is available, if required, for handling refrigerant cylinders;
 - all personal protective equipment is available and being used correctly;
 - the recovery process is supervised at all times by a competent person;
 - recovery equipment and cylinders conform to the appropriate standards.
4. Pump down refrigerant system, if possible.
5. If a vacuum is not possible, make a manifold so that refrigerant can be removed from various parts of the system.
6. Make sure that cylinder is situated on the scales before recovery takes place.
7. Start the recovery machine and operate in accordance with instructions.
8. Do not overfill cylinders (no more than 80 % volume liquid charge).
9. Do not exceed the maximum working pressure of the cylinder, even temporarily.
10. When the cylinders have been filled correctly and the process completed, make sure that the cylinders and the equipment are removed from site promptly and all isolation valves on the equipment are closed off.
11. Recovered refrigerant shall not be charged into another REFRIGERATING SYSTEM unless it has been cleaned and checked

Decommissioning - Unit Labeling Requirements

Equipment shall be labelled stating that it has been de-commissioned and emptied of refrigerant. The label shall be dated and signed. For appliances containing FLAMMABLE REFRIGERANTS, ensure that there are labels on the equipment stating the equipment contains FLAMMABLE REFRIGERANT.

Refrigerant Recovery

When removing refrigerant from a system, either for servicing or decommissioning, it is recommended good practice that all refrigerants are removed safely.

When transferring refrigerant into cylinders, ensure that only appropriate refrigerant recovery cylinders are employed. Ensure that the correct number of cylinders for holding the total system charge is available. All cylinders to be used are designated for the recovered refrigerant and labelled for that refrigerant (i.e. special cylinders for the recovery of refrigerant). Cylinders shall be complete with pressure-relief valve and associated shut-off valves in good working order. Empty recovery cylinders are evacuated and, if possible, cooled before recovery occurs.

The recovery equipment shall be in good working order with a set of instructions concerning the equipment that is at hand and shall be suitable for the recovery of the flammable refrigerant. If in doubt, the manufacturer should be consulted. In addition, a set of calibrated weighing scales shall be available and in good working order. Hoses shall be complete with leak-free disconnect couplings and in good condition.

The recovered refrigerant shall be processed according to local legislation in the correct recovery cylinder, and the relevant waste transfer note arranged. Do not mix refrigerants in recovery units and especially not in cylinders.

If compressors or compressor oils are to be removed, ensure that they have been evacuated to an acceptable level to make certain that flammable refrigerant does not remain within the lubricant. The compressor body shall not be heated by an open flame or other ignition sources to accelerate this process. When oil is drained from a system, it shall be carried out safely.

Refrigerant Removal and Evacuation

When breaking into the refrigerant circuit to make repairs – or for any other purpose conventional procedures shall be used. However, for flammable refrigerants it is important that best practice be followed, since flammability is a consideration.

The following procedure shall be adhered to:

- safely remove refrigerant following local and national regulations;
- evacuate;
- purge the circuit with inert gas (optional for A2L);
- evacuate (optional for A2L);
- continuously flush or purge with inert gas when using flame to open circuit; and
- open the circuit.

The refrigerant charge shall be recovered into the correct recovery cylinders if venting is not allowed by local and national codes. For appliances containing flammable refrigerants, the system shall be purged with oxygen-free nitrogen to render the appliance safe for flammable refrigerants.

This process might need to be repeated several times. Compressed air or oxygen shall not be used for purging refrigerant systems. For appliances containing flammable refrigerants, refrigerants purging shall be achieved by breaking the vacuum in the system with oxygen-free nitrogen and continuing to fill until the working pressure is achieved, then venting to atmosphere, and finally pulling down to a vacuum (optional for A2L). This process shall be repeated until no refrigerant is within the system (optional for A2L). When the final oxygen-free nitrogen charge is used, the system shall be vented down to atmospheric pressure to enable work to take place. The outlet for the vacuum pump shall not be close to any potential ignition sources, and ventilation shall be available.

Charging Procedures

In addition to conventional charging procedures, the following requirements shall be followed.

- Ensure that contamination of different refrigerants does not occur when using charging equipment.
- Hoses or lines shall be as short as possible to minimise the amount of refrigerant contained in them.
- Cylinders shall be kept in an appropriate position according to the instructions.
- Ensure that the REFRIGERATING SYSTEM is earthed prior to charging the system with refrigerant.
- Label the system when charging is complete (if not already).
- Extreme care shall be taken not to overfill the REFRIGERATING SYSTEM.

Prior to recharging the system, it shall be pressure-tested with the appropriate purging gas. The system shall be leak-tested on completion of charging but prior to commissioning. A follow up leak test shall be carried out prior to leaving the site.

Notes

Revision Guide

Pages:	Description:	Date:	By:
All	Document Creation	3 Oct., 2024	SW



OMW5-0026Y 12/24



Product: **Affinity Series**
Type: Geothermal Hydronic Heat Pumps
Size: 10-15 Ton Dual Capacity

Document Type: Operation & Maintenance
Part Number: OMW5-0026Y
Release Date: 12/24