

OPERATION & MAINTENANCE

Affinity Series

Single Speed Hydronic Heat Pump

60Hz / R-454B



OMW5-0025Y





WARNING



WARNING: Before performing service or maintenance operations on the system, turn off main power switches to the unit. Electrical shock could cause serious personal injury.

WARNING: All manufacturer products are designed, tested, and manufactured to comply with the latest publicly released and available edition of UL 60335-2-40 for electrical safety certification. All field electrical connections must follow the National Electrical Code (NEC) guide standards and / or any local codes that may be applicable for the installation.

WARNING: Only factory authorized personnel are approved for startup, check test and commissioning of this unit.

INSTALLER: Please take the time to read and understand these instructions prior to any installation. Installer must give a copy of this manual to the owner.

Definition of Warnings and Symbols

 DANGER	Indicates a situation that results in death or serious injury.
 WARNING	Indicates a situation that could result in death or serious injury.
 CAUTION	Indicates a situation that could result in minor or moderate injury.
NOTICE	Indicates a situation that could result in equipment or property damage.

For the User



WARNING

This appliance is not intended for use by persons (including children) with reduced physical, sensory, or mental capabilities, or lack of experience and knowledge, unless they have been given supervision or instruction concerning use of the appliance by a person responsible for their safety.

Children should be supervised to ensure that they do not play with the appliance.

Keep this manual in a safe place in order to provide your serviceman with necessary information.

NOTICE

NOTICE: To avoid equipment damage, do not leave the system filled in a building without heat during cold weather, unless adequate freeze protection levels of antifreeze are used. Heat exchangers do not fully drain and will freeze unless protected, causing permanent damage.

Table of Contents

UNIT OVERVIEW

General Installation Information	4
Nomenclature	6
AHRI Data	7
Physical Data	9
Dimensional Data	10
Electrical Data	11
Hydronic	17
Accessories and Options	19
External Control	21

OPERATING PRINCIPLES

Antifreeze Corrections	22
Refrigerant Circuit Guideline	23
Heat of Extraction/Heat of Rejection	24
Water Quality	26
Operating Parameters	27
Pressure Drop	28
Operating Limits	28
Flow Rates	29
Aurora Controls Operation	30

SERVICE AND TROUBLESHOOTING

Compressor and Thermistor Resistance	40
Reference Calculations and Legend	41
Preventative Maintenance	42
Troubleshooting	43
Aurora Interface Diagnostic (AID) Tool	44
Preliminary Checkout Procedure	44
Troubleshooting Checklist	45
Control Board Troubleshooting Steps	46
Control Board Troubleshooting Flow Charts	48
Communicating Thermostat Troubleshooting Guide	56
Control Board Signals	58
Jumping the Control Board	61
Troubleshooting	63
Performance Data	66
Service Parts Table	73
Decommissioning	74
Decommissioning Unit Labeling Requirements	74
Refrigerant Recovery	75
Refrigerant Removal and Evacuation	75
Charging Procedures	76

REVISION GUIDE	77
--------------------------	----

General Installation Information

NOTICE: Do not store or install units in corrosive environments or in locations subject to temperature or humidity extremes. Corrosive conditions and high temperature or humidity can significantly reduce performance, reliability, and service life.

NOTICE: A minimum of 24 in. clearance should be allowed for access to front access panel.

NOTICE: To avoid equipment damage, DO NOT use these units as a source of heating or cooling during the construction process. The mechanical components and filters can quickly become clogged with construction dirt and debris, which may cause system damage and void product warranty.

For the Installer

If you are NOT sure how to install or operate the unit, contact your dealer.

Installing and servicing air conditioning and heating equipment can be hazardous due to system pressure and electrical components. Only trained and qualified service personnel should install, repair or service heating and air conditioning equipment. When working on heating and air conditioning equipment, observe precautions in the literature, tags and labels attached to the unit and other safety precautions that may apply.

This manual contains specific information about the required qualification of the working personnel for maintenance, service and repair operations. Every working procedure that affects safety means shall only be carried out by competent persons.

Examples for such working procedures are:

- breaking into the refrigerating circuit;
- opening of sealed components or ventilated enclosures.

Follow all safety codes. Wear safety glasses and work gloves. Use quenching cloth for brazing operations. Have fire extinguisher available for all brazing operations. Follow all procedures to remain in compliance with national gas regulations.

Prior to beginning work on systems containing FLAMMABLE REFRIGERANTS, safety checks are necessary to ensure that the risk of ignition is minimized. Work shall be undertaken under a controlled procedure so as to minimise the risk of a flammable gas or vapor being present while the work is being performed. All maintenance staff and others working in the local area shall be instructed on the nature of work being carried out. Work in confined spaces shall be avoided.

The area shall be checked with an appropriate refrigerant detector prior to and during work, to ensure the technician is aware of potentially toxic or flammable atmospheres. Ensure that the leak detection equipment being used is suitable for use with all applicable refrigerants, i.e. non-sparking, adequately sealed or intrinsically safe.

If any hot work is to be conducted on the refrigerating equipment or any associated parts, appropriate fire extinguishing equipment shall be available to hand. Have a dry powder or CO2 fire extinguisher adjacent to the charging area.

No person carrying out work in relation to a REFRIGERATING SYSTEM which involves exposing any pipe work shall use any sources of ignition in such a manner that it may lead to the risk of fire or explosion. All possible ignition sources, including cigarette smoking, should be kept sufficiently far away from the site of installation, repairing, removing and disposal, during which refrigerant can possibly be released to the surrounding space. Prior to work taking place, the area around the equipment is to be surveyed to make sure that there are no flammable hazards or ignition risks. "No Smoking" signs shall be displayed.

Where electrical components are being changed, they shall be fit for the purpose and to the correct specification. At all times the manufacturer's maintenance and service guidelines shall be followed. If in doubt, consult the manufacturer's technical department for assistance.

The following checks shall be applied to installations using FLAMMABLE REFRIGERANTS:

- the actual REFRIGERANT CHARGE is in accordance with the room size within which the refrigerant containing parts are installed;
- the ventilation machinery and outlets are operating adequately and are not obstructed;
- if an indirect refrigerating circuit is being used, the secondary circuit shall be checked for the presence of refrigerant;
- marking to the equipment continues to be visible and legible. Markings and signs that are illegible shall be corrected;
- refrigerating pipe or components are installed in a position where they are unlikely to be exposed to any substance which may corrode refrigerant containing components, unless the components are constructed of materials which are inherently resistant to being corroded or are suitably protected against being so corroded.

Instructions for Equipment Using R-454B Refrigerant

WARNING

- **Do NOT pierce or burn**
- **Do NOT use means to accelerate the defrosting process or to clean the equipment, other than those recommended by the manufacturer**
- **Be aware that refrigerants may not contain an odor**

WARNING

- **The Appliance should be stored so as to prevent mechanical damage and in a room without continuously operating ignition sources (example: open flames, an operating gas appliance or an operating electric heater)**

General Installation Information

WARNING

Ventilated Area: ensure that the area is in the open or that it is adequately ventilated before breaking into the system of conducting any hot work. A degree of ventilation should continue during the period that the work is carried out. The ventilation should safely disperse any released refrigerant and preferably expel it. Keep ventilation area clear of obstructions!

WARNING

Do NOT use potential sources of ignition in searching for or detection of refrigerant leaks. A halide torch (or any other detector using a naked flame) shall not be used.

The following leak detection methods are deemed acceptable for all refrigerant systems. Electronic leak detectors may be used to detect refrigerant leaks but, in the case of FLAMMABLE REFRIGERANTS, the sensitivity may not be adequate, or may need recalibration. (Detection equipment shall be calibrated in a refrigerant-free area.) Ensure that the detector is not a potential source of ignition and is suitable for the refrigerant used. Leak detection equipment shall be set at a percentage of the LFL of the refrigerant and shall be calibrated to the refrigerant employed, and the appropriate percentage of gas (25% maximum) is confirmed. Leak detection fluids are also suitable for use with most refrigerants but the use of detergents containing chlorine shall be avoided as the chlorine may react with the refrigerant and corrode the copper pipe-work. NOTE Examples of leak detection fluids are bubble method, fluorescent method agents. If a leak is suspected, all naked flames shall be removed/extinguished. If a leakage of refrigerant is found which requires brazing, all of the refrigerant shall be recovered from the system, or isolated (by means of shut off valves) in a part of the system remote from the leak. Removal of refrigerant shall follow the procedure outlined in this manual.

Installation Site

This equipment has been evaluated to be installed up to a maximum altitude of 3000m (9843ft) and should not be installed at an altitude greater than 3000m. For installation only in locations not accessible to the general public.

WARNING

For appliances using A2L refrigerants connected via an air duct system to one or more rooms, only auxiliary devices approved by the appliance manufacturer or declared suitable with the refrigerant shall be installed in connecting ductwork. The manufacturer shall list in the instructions all approved auxiliary devices by manufacturer and model number for use with the specific appliance, if those devices have a potential to become an ignition source.

Installation Space Requirements

NOTE: Equipment with refrigerant charge less than 62 oz does not require have a minimum floor area requirement and does not require a refrigerant leak detection sensor. The sensor might be added as a feature.

WARNING

Equipment containing R-454B refrigerant shall be installed, operated, and stored in a room with floor area larger than the area defined in the "Minimum Floor Area" chart based on the total refrigerant charge in the system. This requirement applies to indoor equipment with or without a factory refrigerant leakage sensor.

CAUTION

It is not recommended to use a potable water source for this equipment water supply.

WARNING

This equipment comes with a factory installed Refrigerant Detection Device which is capable of determining its specified end-of-life and replacement instructions. Refrigerant sensors for refrigerant detection systems shall only be replaced with sensors specified by the appliance manufacture.

WARNING

Take sufficient precautions in case of refrigerant leakage. If refrigerant gas leaks, ventilate the area immediately.
POSSIBLE RISKS: Excessive refrigerant concentrations in a closed room can lead to oxygen deficiency

WARNING

ALWAYS recover the refrigerant. Do NOT release them directly into the environment. Follow handling instructions carefully in compliance with national regulations.

WARNING

Check that cabling will not be subject to wear, corrosion, excessive pressure, vibration, sharp edges or any other adverse environmental effects. The check shall also take into account the effects of aging or continual vibration from sources such as compressors or fans.

Nomenclature

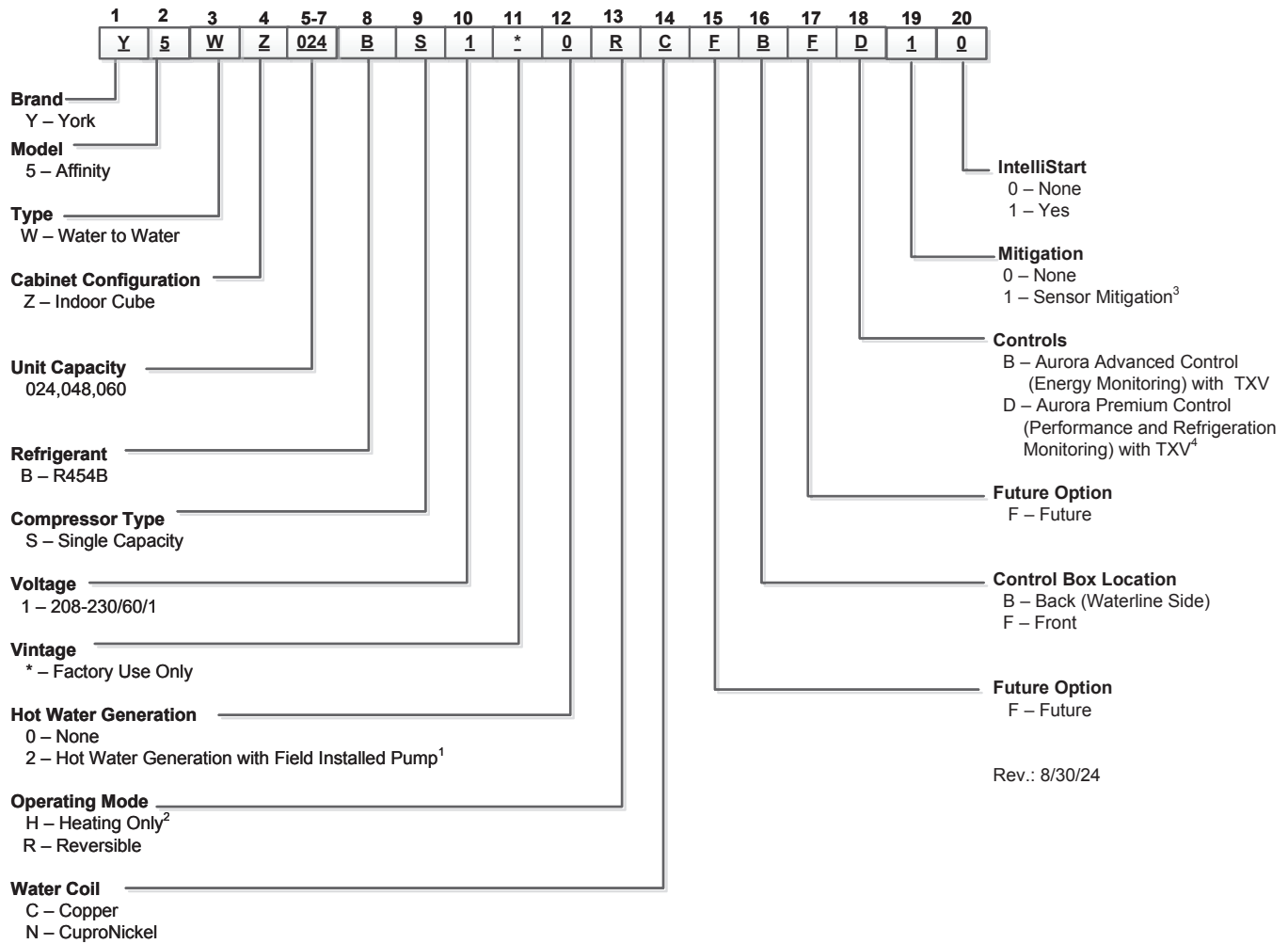

Rev.: 8/30/24

NOTES: 1 – Available on 048 and 060 only. Hot water generator requires field installed external pump kit.
 2 – 024 heating only model is available only with copper double wall vented load coax for potable water, and is not designed to be converted to dedicated cooling units.
 3 – Mitigation required on 060 model, not available on 024 and 048 models.
 4 – Flow meter for Performance option is shipped with unit, and must be externally field installed.

AHRI Data

The *SWZ is rated in accordance to the upcoming performance standard AHRI/ASHRAE/ISO 13256-2. This new standard will have three major categories: Water Loop, Ground Water, and Ground Loop.

Unit of Measure: The Cooling COP

The cooling efficiency is measured in EER (US version measured in Btuh per Watt. The Metric version is measured in a cooling COP (Watt per Watt) similar to the traditional COP measurement.

Pump Power Correction Calculation

Within each model, only one water flow rate is specified for all three groups and pumping Watts are calculated using the following formula. This additional power is added onto the existing power consumption.

• Pump power correction = (gpm x 0.0631) x (Press Drop x 2990) / 300

Where ‘gpm’ is waterflow in gpm and ‘Press Drop’ is the pressure drop through the unit heat exchanger at rated water flow in feet of head.

ISO Capacity and Efficiency Calculations

The following equations illustrate cooling calculations:

• ISO Cooling Capacity = Cooling Capacity (Btuh) x 3.412

• ISO EER Efficiency (W/W) = ISO Cooling Capacity (Btuh) x 3.412 / [Power Input (Watts) + Pump Power Correction (Watt)]

The following equations illustrate heating calculations:

• ISO Heating Capacity = Heating Capacity (Btuh) x 3.412

• ISO COP Efficiency (W/W) = ISO Heating Capacity (Btuh) x 3.412 / [Power Input (Watts) + Pump Power Correction (Watt)]

Test Conditions

	ISO/AHRI 13256-2 WLHP	ISO/AHRI 13256-2 GWHP	ISO/AHRI 13256-2 GLHP
Cooling			
Liquid Entering Indoor Side - °F <i>Standard Rating Test</i>	53.6	53.6	53.6
Liquid Entering Heat Exchanger - °F <i>Part-load Rating Test</i>	86	59	77
Liquid Entering Heat Exchanger Fluid Flow Rate	86 *	59 *	68 *
Heating			
Liquid Entering Indoor Side - °F <i>Standard Rating Test</i>	104	104	104
Liquid Entering Outdoor-side Heat Exchanger - °F <i>Part-load Rating Test</i>	68	50	32
Liquid Entering Outdoor-side Heat Exchanger Fluid Flow Rate	68 *	50 *	41 *

Conversions

Water Flow (lps) = GPM x 0.0631

Press Drop (Pascals) = Press Drop (ft hd) x 2990

NOTES: *Flow rate is specified by the manufacturer
 WLHP = Water Loop Heat Pump; GWHP = Ground Water Heat Pump;
 GLHP = Ground Loop Heat Pump

AHRI Data

Model	Capacity Modulation	Flow Rate		Water Loop Heat Pump				Ground Water Heat Pump				Ground Loop Heat Pump			
				Cooling 86°F Source 53.6°F Load		Heating 68°F Source 104°F Load		Cooling 59°F Source 53.6°F Load		Heating 50°F Source 104°F Load		Cooling 77°F Source 53.6°F Load		Heating 32°F Source 104°F Load	
		Load Gpm	Source Gpm	Capacity Btuh	EER Btuh/W	Capacity Btuh	COP	Capacity Btuh	EER Btuh/W	Capacity Btuh	COP	Capacity Btuh	EER Btuh/W	Capacity Btuh	COP
024	Full	7	7	24,400	14.6	30,700	4.3	26,000	22.2	27,000	3.8	24,700	16.1	22,000	3.1
048	Full	15	15	48,100	14.0	63,000	4.4	51,100	20.9	52,600	3.6	49,700	16.1	42,700	3.1
060	Full	18	18	55,300	13.7	76,500	4.5	62,800	20.4	63,400	3.8	58,800	16.1	50,200	3.1

All ratings based upon 208V operation

10/11/24



Physical Data

Model	024	024 Heating	048	060
Compressor (1 each)	Scroll			
Factory Charge R410a, oz [kg]	46.0 [1.30]	42.0 [1.19]	62 [1.76]	82 [2.32]
Coax & Piping Water Volume - gal [l]	.89 [3.38]	.89 [3.38]	1.4 [5.25]	1.6 [6.13]
Weight - Operating, lb [kg]	225 [102.1]	225 [102.1]	325 [147.4]	345 [156.5]
Weight - Packaged, lb [kg]	247 [112.0]	247 [112.0]	340 [154.2]	360 [163.3]

Dimensional Data

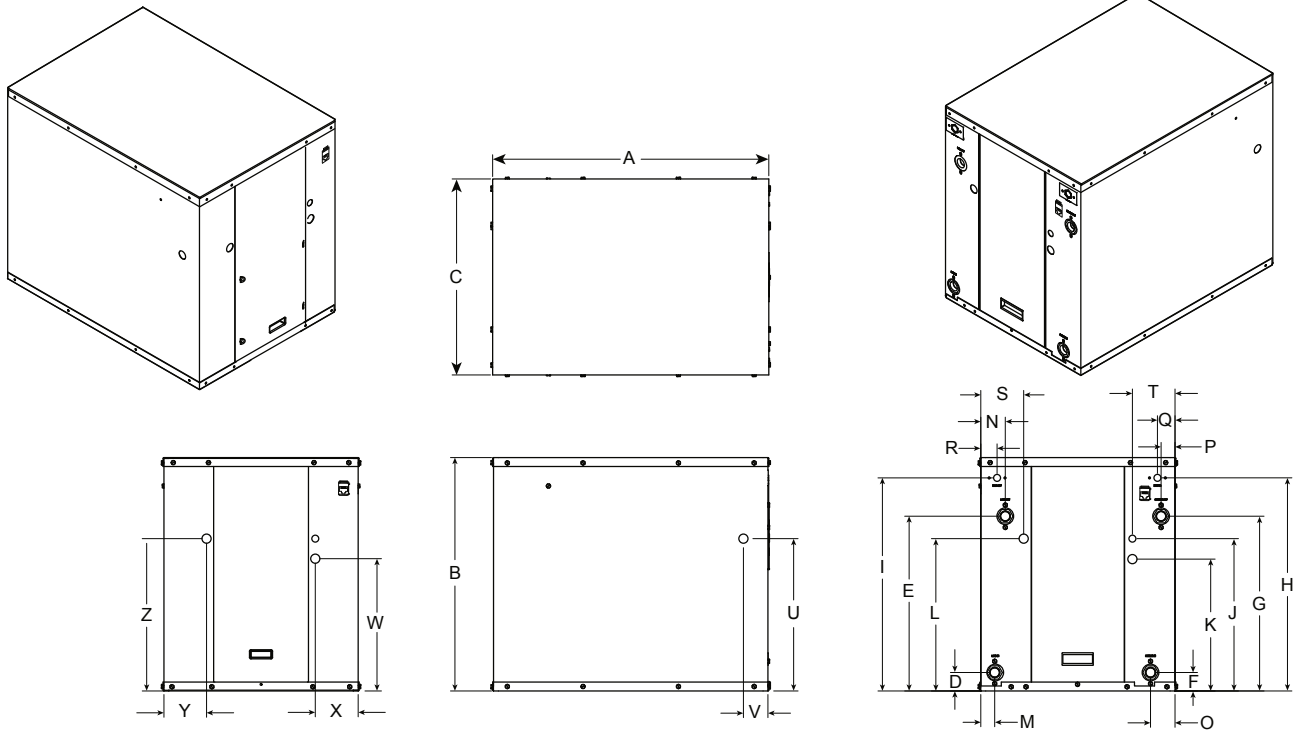

2/15/16

Model	Overall Cabinet			Water Connections									Electrical Knockouts			
	A	B	C	D	E	F	G	H	I				J 1/2" cond	K 3/4" cond	L 3/4" cond	
	Depth	Height	Width	Load Liquid In	Load Liquid Out	Source Liquid In	Source Liquid Out	HWG In	HWG Out	Load Water FPT	Source Water FPT	HWG Water FPT	Low Voltage	Ext Pump	Power Supply	
024	in.	23.5	26.1	19.5	10.0	22.2	10.0	22.2	-	-	1"	1"	-	16.0	14.2	14.2
	cm.	59.7	66.3	49.5	25.4	56.4	25.4	56.4	-	-	25.4	25.4	-	40.6	36.1	36.1
048	in.	31.0	26.2	22.0	2.2	20.6	2.2	20.6	23.9	23.9	1-1/4"	1-1/4"	1/2"	17.1	14.8	17.1
	cm.	78.7	66.5	55.9	5.6	52.3	5.6	52.3	60.7	60.7	31.8	31.8	12.7	43.4	37.6	43.4
060	in.	31.0	26.2	22.0	2.4	23.0	2.4	23.0	20.6	20.6	1-1/4"	1-1/4"	1/2"	17.1	14.8	17.1
	cm.	78.7	66.5	55.9	6.1	58.4	6.1	58.4	52.3	52.3	31.8	31.8	12.7	43.4	37.6	43.4

Model	Water Connections										Electrical Knockouts				
	M	N	O	P	Q	R	S	T	U	V	W	X	Y	Z	
	Load Liquid In	Load Liquid Out	Source Liquid In	Source Liquid Out	HWG In	HWG Out	Power Supply	Low Voltage	Side Power Supply	Side Power Supply	Ext Pump	Ext Pump	Power Supply	Power Supply	
024	in.	2.4	2.4	2.4	2.4	-	-	3.5	2.9	14.9	2.6	2.1	1.8	2.9	4.1
	cm.	6.1	6.1	6.1	6.1	-	-	8.9	7.4	37.8	6.6	5.3	4.4	7.4	10.4
048	in.	1.8	3.6	3.6	1.8	2.1	1.8	4.8	4.8	17.1	2.8	14.9	4.8	4.8	17.1
	cm.	4.6	9.1	9.1	4.6	5.3	4.6	12.2	12.2	43.4	7.1	37.8	12.2	12.2	43.4
060	in.	1.8	4.0	4.0	1.8	4.2	1.4	4.8	4.8	17.1	2.8	14.9	4.8	4.8	17.1
	cm.	4.6	10.2	10.2	4.6	10.7	3.6	12.2	12.2	43.4	7.1	37.8	12.2	12.2	43.4

Note: Plastic front panel extends 1.4" (3.56 cm) beyond front of cabinet.

07/16/24

Electrical Data

Unit Model	Rated Voltage	Voltage Min/Max	Compressor				Load Pump	Source Pump	Total Unit FLA	Min Ckt Amp	Maximum Fuse/HACR
			MCC	RLA	LRA	LRA*					
024	208-230/60/1	187/253	19.8	12.7	75.6	26.5	1.8	5.4	19.9	23.1	35
048	208-230/60/1	187/253	37.0	23.7	157.0	55.00	1.8	5.4	30.9	36.8	60
060	208-230/60/1	187/253	43.0	27.5	170.0	59.5	1.8	5.4	34.7	41.6	70

Notes: All fuses type "D" time delay (or HACR circuit breaker in USA).
 Source pump amps shown are for up to a 1/2 HP pump
 Load pump amps shown are for small circulators.
 *With optional IntelliStart

9/12/24

Control Box

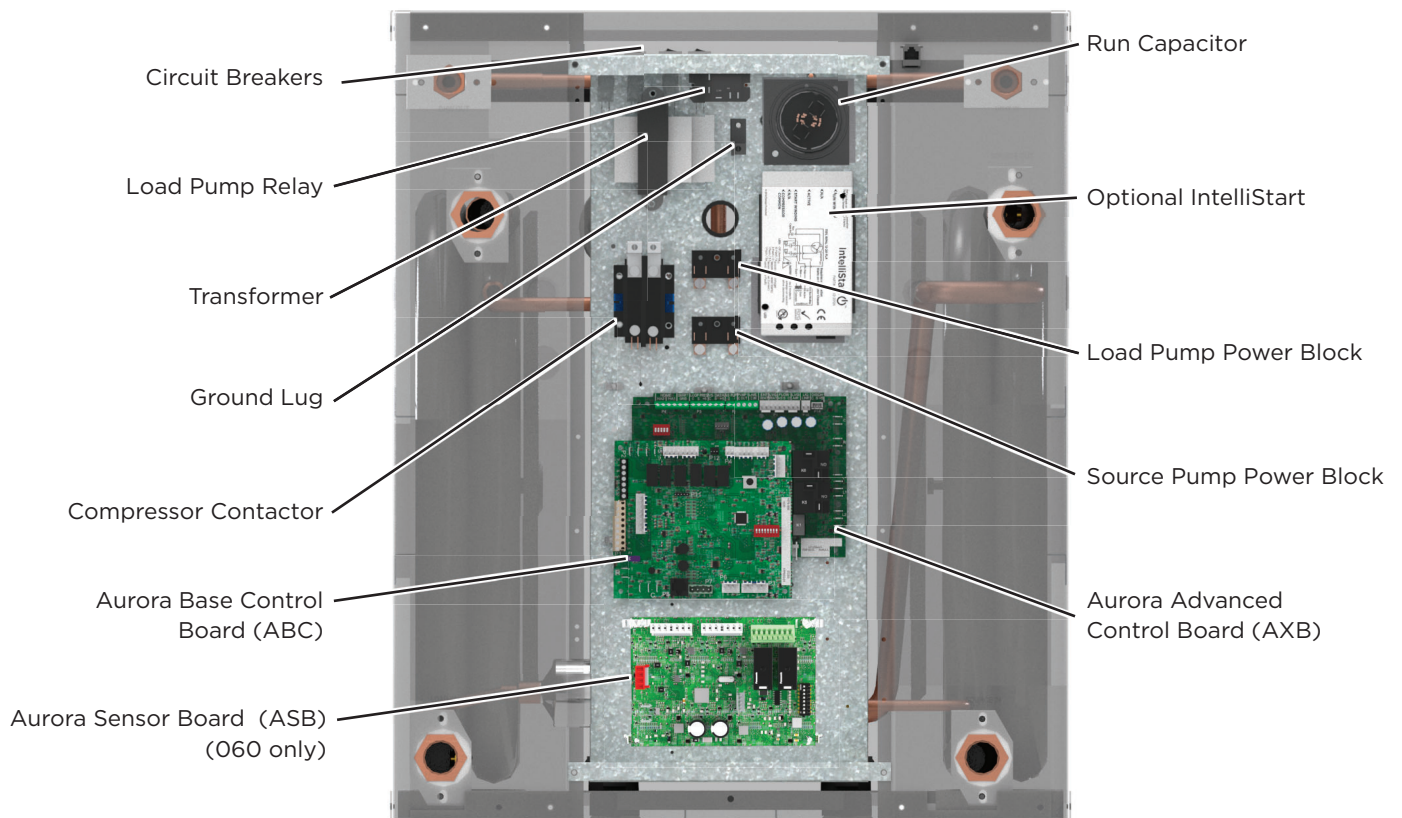

Electrical Information

 **WARNING**

During repairs to sealed components, all electrical supplies shall be disconnected from the equipment being worked upon prior to any removal of sealed covers, etc. If it is absolutely necessary to have an electrical supply to equipment during servicing, then a permanently operating form of leak detection shall be located at the most critical point to warn of a potentially hazardous situation.

Sealed electrical components shall be replaced.

 **WARNING**

Do not apply any permanent inductive or capacitance loads to the circuit without ensuring that this will not exceed the permissible voltage and current permitted for the equipment in use.

Intrinsically safe components must be replaced.

Replace components only with parts specified by the manufacturer. Other parts may result in the ignition of refrigerant in the atmosphere from a leak.

NOTE The use of silicon sealant can inhibit the effectiveness of some types of leak detection equipment. Intrinsically safe components do not have to be isolated prior to working on them.

Electrical Information

Fixed Speed Flow Center

The pump(s) will be connected to the terminals on PB1 in the unit electrical box as shown in Figure 3a. The pumps will automatically be cycled as required by the unit or by a signal from another unit sharing the flow center (See Figures 5 and 6). Pumps are protected by circuit breakers (CB) shown in Figure 3a.

Figure 3a: Single/Dual Cap Unit Wiring for Loop Pumps

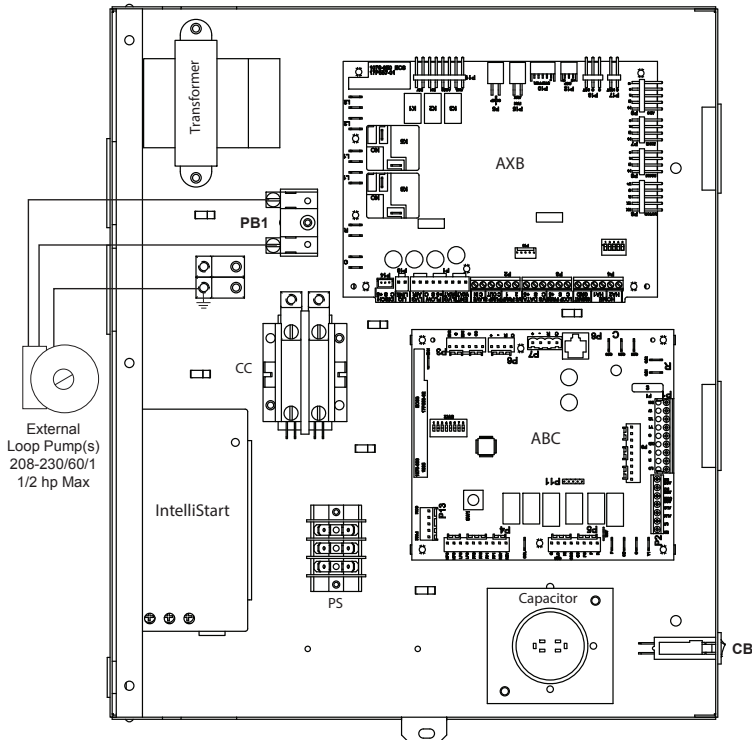

NOTES: For closed loop systems with antifreeze protection, set SW2 DIP Switch #1 to the "Loop" position on units with the Aurora control and SW2-2 should be set to "Loop" on the Premier control.

Figure 3c: FCM and FCL Flow Center Wiring (Not Referenced)

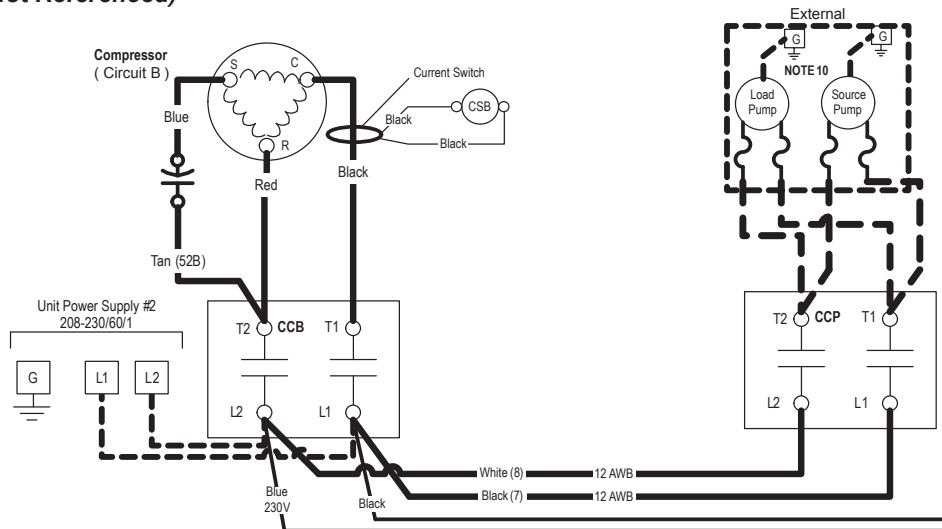

NOTES: FCM and FCL Flow Centers must be wired to a separate contactor (20 amp minimum). The HydroZone Accessory Control Box works best for this application.

Electrical Information

Variable Speed Flow Center

Single Pump Variable Speed Flow Center

If a variable speed single pump flow center is used, the flow center will come with two red and one green wires for the high voltage wiring. The variable speed pump **MUST** be powered at all times and therefore **MUST** be wired to the “L” side of electrical system or damage to the pump will occur (pump cannot be powered from “T” side of compressor contactor). Connect the red HIGH VOLTAGE wires to L1 and L2 on the AXB, connect the green GROUND wire to the ground lug, as shown in figure 4a. Follow all electrical and local codes for wiring.

The variable speed UPMXL 25-124 pump also requires a low voltage signal to operate properly, if the low voltage signal isn't present the pump will run at 100%. Route the low voltage harness connected to the pump to the AXB screw terminals on P2 and P3 connectors per diagram 4b.

Both the low and high voltage harnesses are labeled. The pump will be automatically cycled as required either by the unit or by a signal from another unit sharing the same flow center. Pumps are protected by circuit breakers as shown on the unit schematic.

Figure 4a: Single VS Pump High Voltage Wiring

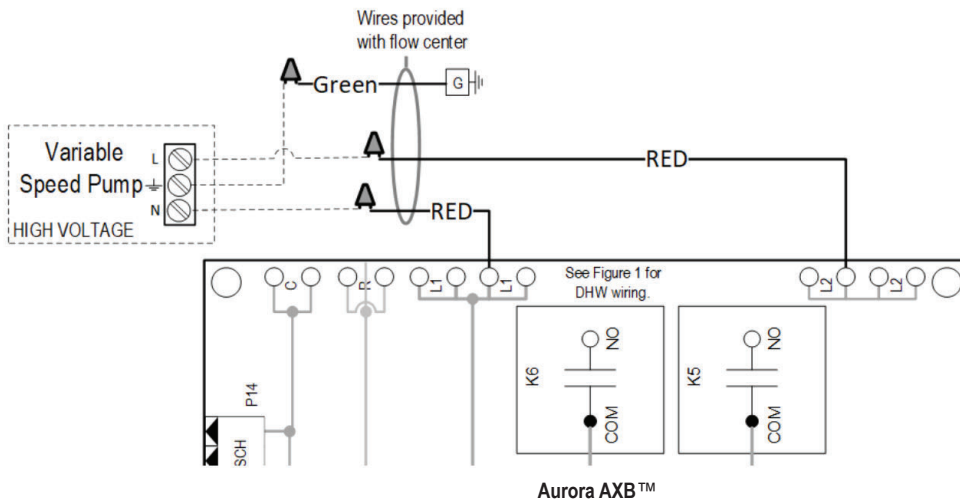
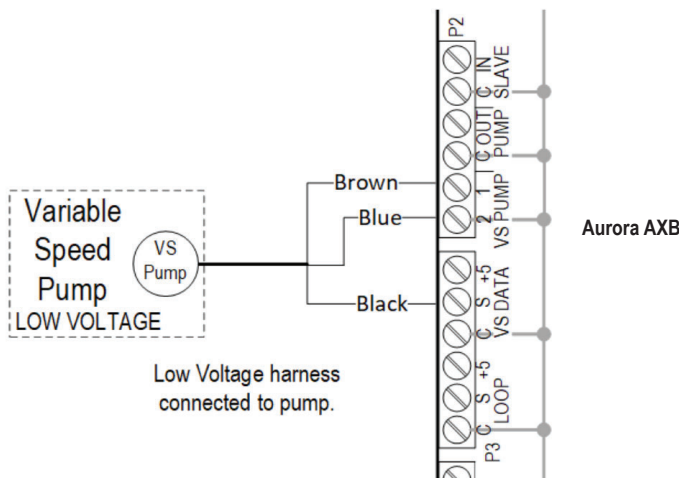

Figure 4b: Single VS Pump Low Voltage Wiring



Note: Aurora AXB must be used to control the UPMXL 25-124 pump.

Electrical Information

Variable Speed Flow Center cont.

Two Pump Variable Speed Flow Center

If a variable speed two pump flow center is used, the flow center will come with four red and two green wires for the high voltage wiring. The second set of (2) red and (1) green wires is provided for installation flexibility. The variable speed pump **MUST** be powered at all times and therefore **MUST** be wired to the “L” side of electrical system or damage to the pump will occur (pump cannot be powered from “T” side of compressor contactor). The UPMXL 25-124 pump has screw terminals for the high voltage connection. Connect the red HIGH VOLTAGE wires to L1 and L2 on the AXB, connect the green GROUND wire to the ground lug, as shown in figure 4d. Follow all electrical and local codes for wiring.

The variable speed UPMXL 25-124 pump also requires a low voltage signal to operate properly, if the low voltage signal isn't present the pump will run at 100%. Route the low voltage harness connected to the right hand pump to the AXB screw terminals on P2 and P3 connectors. Route the low voltage harness connected to the left hand pump to the AXB screw terminals on P2 and P3 connector per figure 4c. The black wire on the left hand pump will have a label on it that reads **“DO NOT CONNECT THIS WIRE. ONLY ONE VS PUMP FEEDBACK SIGNAL CAN BE CONNECTED TO AXB BOARD”**.

Both the low and high voltage harnesses are labeled. The pump will be automatically cycled as required either by the unit or by a signal from another unit sharing the same flow center. Pumps are protected by circuit breakers as shown on the unit schematic.

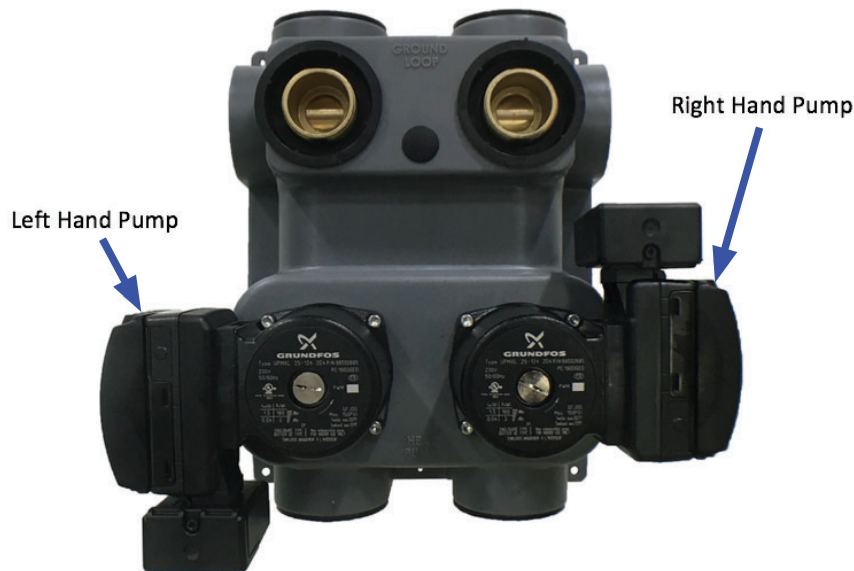

NOTE: Both pumps will speed up and slow down together.

Electrical Information

Variable Speed Units cont.

Two Pump Variable Speed Flow Center cont.

The use of the black wire on the left hand pump is ONLY to be connected for troubleshooting of the pumps. The left hand pump will have a closed end splice connector crimped to the black wire. Cut the closed end splice connector off and strip the wire. During troubleshooting remove the black wire from the right hand pump from the AXB P3 VS DATA S screw terminal and connect the black wire from the left hand pump to the same location. After the troubleshooting is complete remove the black wire from the left hand pump and connect the black wire from the right hand pump.

Place electrical tape or wire nut on the left hand pump black wire. The two pump variable speed flow center cannot have each UPMXL 25-124 pump wired to two separate heat pumps otherwise damage to the pumps will occur (unless it's an NPD Series flow center).

Figure 4c: Two VS Pump Low Voltage Wiring

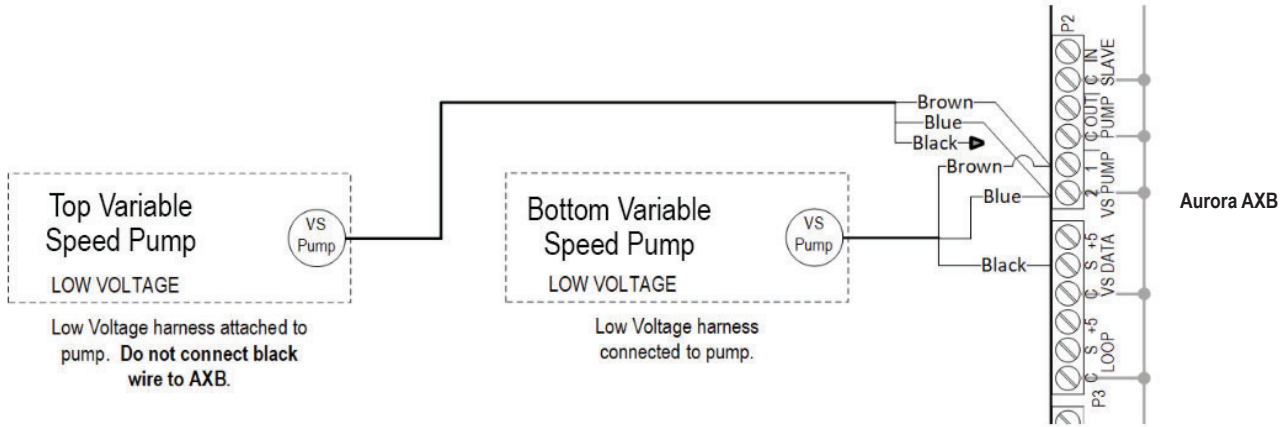

Note: Aurora AXB must be used to control the UPMXL 25-124 pump.

Figure 4d: Two VS Pump High Voltage Wiring

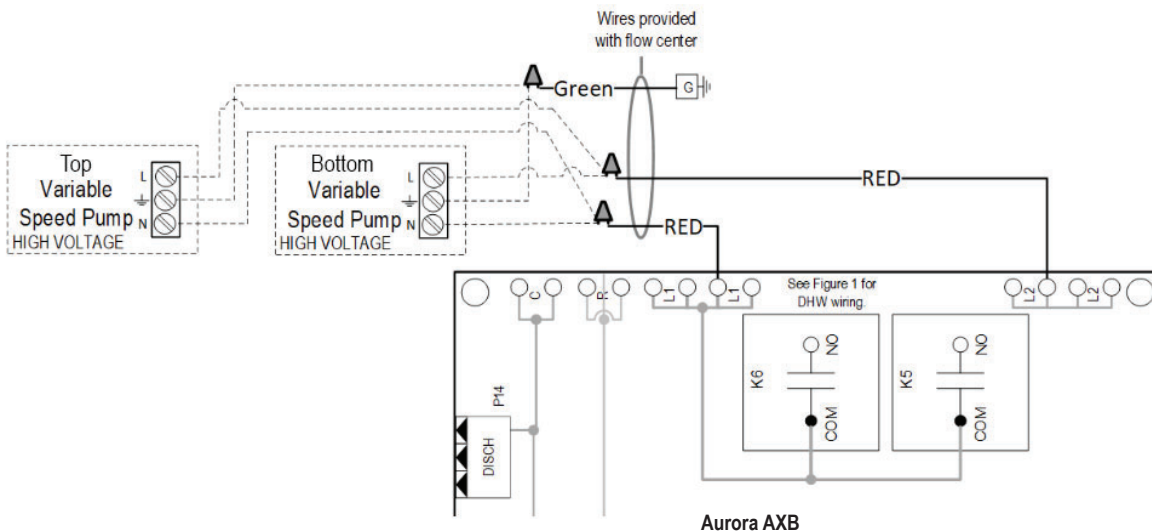

Hydronic

General guidelines are shown below for component selection and design/installation criteria for the piping system. Local codes supersede any recommendations in this manual.

Shut Off/Flow Regulation Valves

Use full port ball valves or gate valves for component isolation. If valves are going to be used frequently, ball valves are recommended. Globe valves are designed for flow regulation. Always install globe valves in the correct direction (fluid should enter through the lower body chamber).

Check valves

Swing check valves must be installed in the horizontal position with the bonnet of the valve upright. Spring check valves can be mounted in any position. A flow check valve is required to prevent thermo-siphoning (or gravity flow) when the circulator pump is off or when there are two circulators on the same system.

Storage (Buffer) Tank

A buffer tank is required for all hydronic heating systems using manufacturer heat pumps. The tank should be sized to provide 2 gallons of storage capacity for every one thousand Btuh's of nominal heat pump capacity.

Pressure Relief Valve

Most codes require the use of a pressure relief valve if a closed loop heat source can be isolated by valves. Even if local code does not require this device, manufacturer recommends its installation. If the pressure relief valve in the buffer tank is not already rated at 30 psi (207 kPa) maximum pressure, one must be installed. The pressure relief valve should be tested at start up for operation. Note that the waste pipe must be at least the same diameter as the valve outlet (never reduce), and valves may not be added to this pipe. The bottom of the pipe must terminate at least 6" (15 cm) above the floor. If the piping is connected to a drain, there must be an air gap.

Backflow Prevention Check Valves

Most codes require backflow prevention check valves. Note that a single check valve is not equal to a backflow prevention check valve. Even if local code does not require this device, manufacturer recommends its installation. This is particularly important if the system will use antifreeze.

Pressure Reducing Valves or Feed Water Valves

This valve lowers the pressure from the make-up water line to the system. Most are adjustable and directional. A "fast fill" valve is required for initial filling of the system. Some have screens, which must be cleaned after the initial filling. If there is a restriction in the screen, the system could go to 0 psi (0 kPa), potentially causing pumps(s) failure. A valve should be installed on each side of the pressure reducing valve for servicing. Both valves should have tags reading "Do not shut this valve under normal operation - service valve only."

Expansion Tanks

Expansion tanks are required on hydronic systems to help absorb the pressure swings as the temperature in the system fluctuates.

Elbows/Tees

Long radius elbows or two 45° elbows will lower pressure drop. Standard tees have a greater restriction on the "T" portion than tees designed with angled outlet ports.

Antifreeze

Antifreeze is required if any of the piping system is located in areas subject to freezing.

Dielectric Unions

Dielectric unions are recommended whenever connecting two dissimilar metals to one and other to prevent electro-galvanic corrosion.

When using the various types of hydronic heat distribution systems, the temperature limits of the geothermal system must be a major consideration. In new construction, the distribution system can easily be designed with the temperature limits in mind. In retrofits, care must be taken to address the operating temperature limits of the existing distribution system. The maximum storage tank temperature for the unit is 130°F (54.4°C). Typical in floor radiant systems require much lower temperatures, typically 100°-115°F, which is ideal for the *5WZ.

Hydronic

If using a Geothermal Storage tank there will be two red wires exiting out of the top of the tank. These red wires extend internally down to the thermistor/tank thermostat section of the tank. Remove the bottom tank cover to expose the red wires as well as the yellow tank thermistor wires.

HydroZone

If using HydroZone control, connect the two red wires to the two yellow wires using wire nuts. Next, connect the two red wires from the top of the Geothermal Storage tank to "TS" and "GND" on the HydroZone. The "OAT" and "GND" terminals on the HydroZone are used for an outdoor air sensor.

HydroStat

If using HydroStat control, connect the two red wires to the yellow wires using wire nuts. Next, connect the two red wires from the top of the Geothermal Storage tank to "TS" and "GND" on the HydroStat. The "OAT" and "GND" terminals on the HydroStat are used to connect the controller to the ELWT (Entering Load Water Temperature) well point sensor. This sensor is located on the load side entering water line inside the unit.

For other field installed controllers, these two red wires will need wired to the appropriate sensor input terminals. Another option for connection is to connect the thermostat on the Geothermal Storage tank directly to "R" and "Y1" on the ABC board.

Adequate rate of flow (GPM) is very important to system performance and long term reliability. Follow the guidelines for recommended flow in the recommendations table.

Geothermal Storage Tank Thermostat and Thermistor

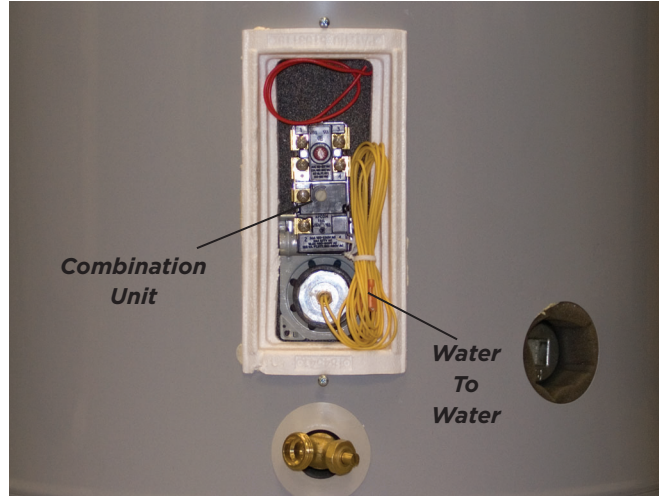

Thermistor Wires Connected to TS and GND on HydroZone Controller.

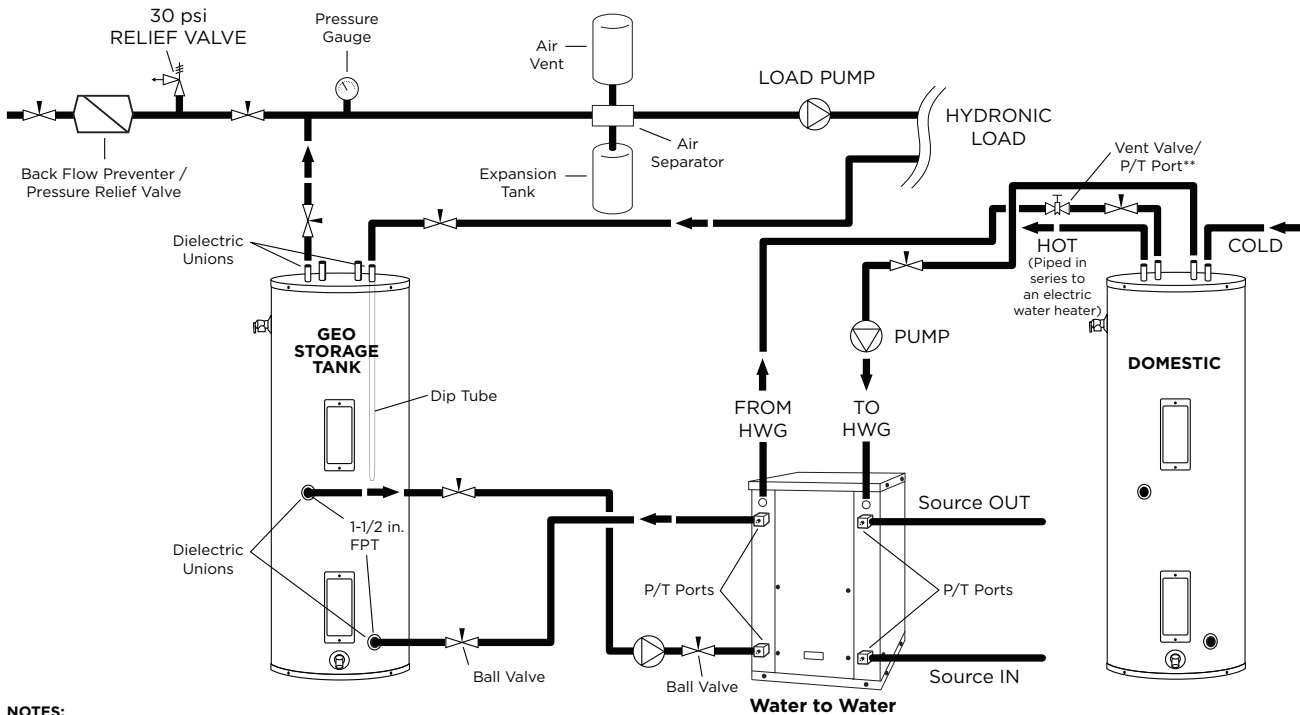

- NOTES:**
- * A 30 psi pressure relief valve (Part No: SRV30) should be used in hydronic applications.
 - ** Vent valve or P/T port at highest point in return line prior to ball valve.

NOTE: Due to compressor reliability direct to load application are not recommended. A buffer tank must be installed in the system.

Accessories and Options

Earth Loop Pump Kit (Field Installed)

A specially designed one or two-pump module provides all liquid flow, fill and connection requirements for independent single unit systems (230/60/1 only). The one-pump module is capable of 20 feet of head at 16.0 GPM, while the two-pump module is capable of 40 feet of head at 16.0 GPM.

Hot Water Generator (Factory Installed, 048 and 060 Only)

An optional heat reclaiming hot water generator coil constructed of vented double-wall copper construction suitable for potable water is available. The coil is factory mounted inside the cabinet. A DPK5 pump kit is required (field installed), which includes a HWG tank connection and a temperature limit pump shutoff.

Load-side Pump Kit (Field Installed)

Four (4) load pump kits are available to provide all liquid flow requirements for independent single unit systems (230/60/1 only). Manufacturer part number **24S516-10** (Grundfos UPS15-42RU) is a composite body pump. **EWPK2** (Grundfos UP26-64BF) is a bronze body pump. Bronze or composite body pumps should be used when water conditions exist that are not compatible with cast iron or for applications such as domestic water heating. Manufacturer part number **EWPK1** (1" FPT flange) and **EWPK3** (1 1/4" FPT flange) come with a cast iron body pump (Grundfos UP26-99F) that can be used for hydronic heating applications.

Calculate the system pressure drop then refer to the pump curves to select the proper pump. All four of the manufacturers pump kits can be used for hydronic heating applications as long as they meet the flow requirements. If the flow requirements are outside the pump curve, an alternate pump will need to be obtained to maintain the necessary flow.

IntelliStart®

The optional IntelliStart single phase soft starter will reduce the normal start current (LRA) by 60-70%. This allows the heat pump to go off-grid. Using IntelliStart also provides a substantial reduction in light flicker, reduces start-up noise, and improves the compressor's start behavior. IntelliStart is available in a field retrofit kit (manufacturer part number **IS60RKL** or **IS60RKS**) or as a factory installed option.

Water Connection Kits (Field Installed)

Water connection kits are available to facilitate loop side and load side water connections.

- **MA4FPT** - Forged brass 1" MPT x 1" FPT square street elbow with P/T plug for 018-040 water side connections
- **MA5FPT** - Forged brass 1.25" MPT x 1.25" FPT square street elbow with P/T plug for 050-075 water side connections
- **WFI-HKM-125-24-MO** - 1 inch x 24 inch stainless steel braided hose kit
- **WFI-HKM-100-24-MO** - 1 1/4 inch x 24 inch stainless steel braided hose kit

UPS15-42RU Three-Speed Pump Curve

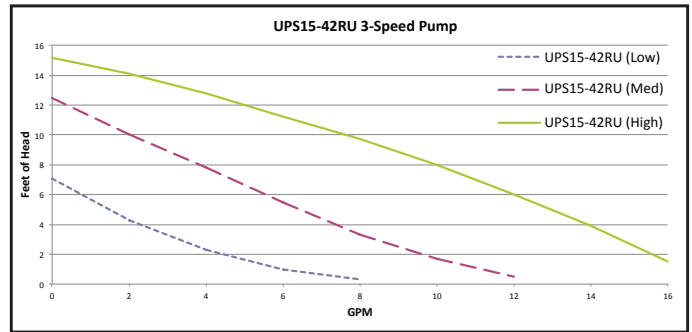

UP26-64BF and UP26-99F Single and Two Pump Curve

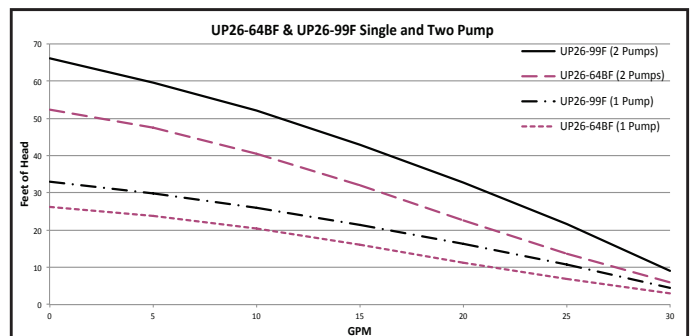

NOTE: Never use piping smaller than 1 inch. Limit length of pipe to 50 feet or less.

Type L Copper Pressure Loss Ft of Hd per 100 ft

GPM	Type L Copper Tube				
	3/4	1	1-1/4	1-1/2	2
2	1.5				
3	3.2				
4	5.5	1.4			
5	8.5	2.1			
6		2.9	1.1		
7		3.9	1.4		
8		5.0	1.8		
9		6.1	2.3	0.9	
10		7.5	2.8	1.1	
12			3.9	1.6	
14			5.2	2.1	
16			6.6	2.7	
18			8.2	3.4	
20			10.0	4.1	1.1
22				5.0	1.3
25				6.3	1.6
30					2.2
35					2.9
40					3.8
45					4.7
50					5.7

NOTE: Standard piping practice limits pressure drop to 4 feet of hd per 100 feet in 2 inch and larger pipe.

Accessories and Options

Geo Storage Tank Dimensions

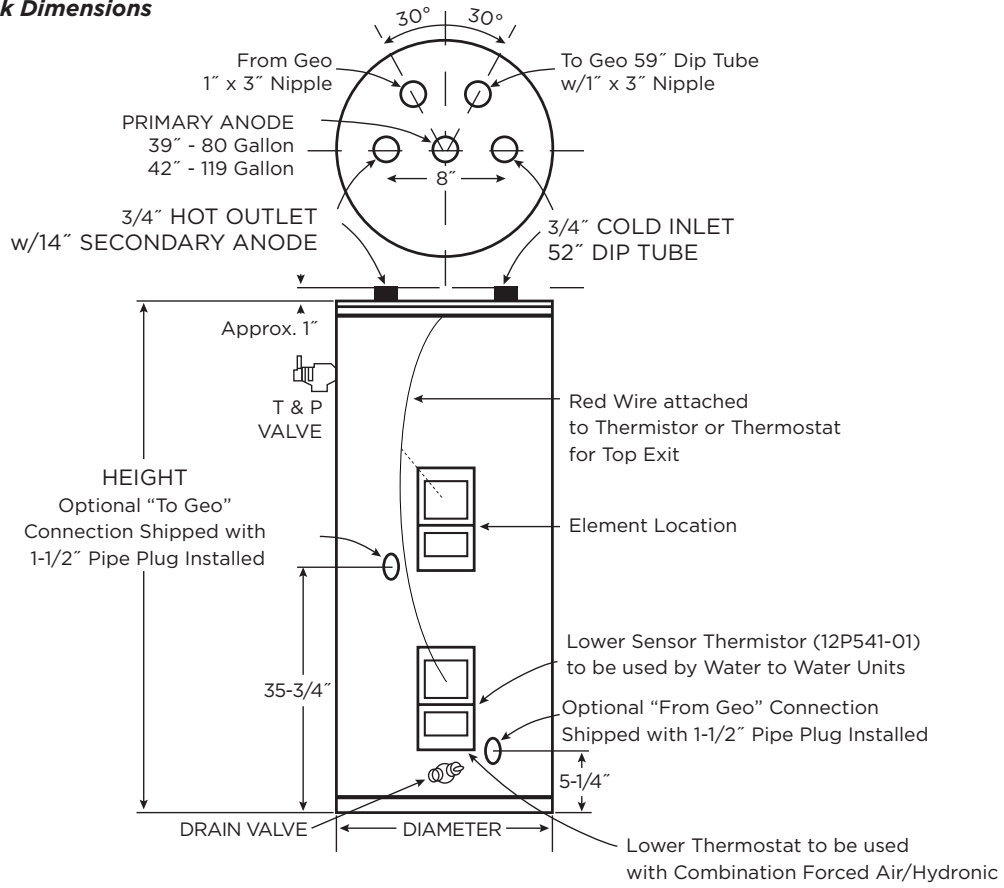

MODEL NUMBER	GALLON CAPACITY	ELEMENT WATTAGE (240 VOLT)	NUMBER OF ELEMENTS	R VALUE	DIMENSIONS IN INCHES		APPROX. SHIPPING WEIGHT (lbs.)
					HEIGHT	DIAMETER	
GEO-STORAGE-80	80	4500	1	16	63-1/4	24	204
GEO-STORAGE-120	119	4500	1	16	63-1/4	28	311

External Control

An external controller is necessary for operation. For water storage tank set point control the HydroStat HZC, and HZO may be used. A field supplied aquastat may also be used as the external control to the heat pump.

HydroStat features:

- Communicating Controller
- Pump Sampling
- 2 1/2" x 2 1/2" LCD display and five push buttons serve as the human interface
- Controls and regulates water tank temperature
- Fahrenheit or Celsius
- Symphony Compatibility
- Single Stage

HydroZone HZC features:

- 2 1/2" x 2 1/2" LCD display and five push buttons serve as the human interface
- Controls and regulates water tank temperature
- Fahrenheit or Celsius
- Outdoor reset
- Warm weather shutdown
- Single Stage

HydroZone HZO features:

- HZC mounted on 7.5" x 7.5" x 3.25" electrical box
- HydroZone relay board
- 2 1/2" x 2 1/2" LCD display and five push buttons serve as the human interface
- Controls and regulates water tank temperature
- Fahrenheit or Celsius
- Outdoor reset
- Warm weather shutdown
- Staging (up to 4 stages)
- Lead/Lag (when staging)

Antifreeze Corrections

Catalog performance can be corrected for antifreeze use. Please use the following table and note the example given.

Antifreeze Type	Antifreeze % by wt	Heating		Cooling		Pressure Drop
		Load	Source	Load	Source	
EWT - °F [°C]		80 [26.7]	30 [-1.1]	50 [10.0]	90 [32.2]	30 [-1.1]
Water	0	1.000	1.000	1.000	1.000	1.000
Ethylene Glycol	10	0.990	0.973	0.976	0.991	1.075
	20	0.978	0.943	0.947	0.979	1.163
	30	0.964	0.917	0.921	0.965	1.225
	40	0.953	0.890	0.897	0.955	1.324
	50	0.942	0.865	0.872	0.943	1.419
Propylene Glycol	10	0.981	0.958	0.959	0.981	1.130
	20	0.967	0.913	0.921	0.969	1.270
	30	0.946	0.854	0.869	0.950	1.433
	40	0.932	0.813	0.834	0.937	1.614
	50	0.915	0.770	0.796	0.922	1.816
Ethanol	10	0.986	0.927	0.945	0.991	1.242
	20	0.967	0.887	0.906	0.972	1.343
	30	0.944	0.856	0.869	0.947	1.383
	40	0.926	0.815	0.830	0.930	1.523
	50	0.907	0.779	0.795	0.911	1.639
Methanol	10	0.985	0.957	0.962	0.986	1.127
	20	0.969	0.924	0.929	0.970	1.197
	30	0.950	0.895	0.897	0.951	1.235
	40	0.935	0.863	0.866	0.936	1.323
	50	0.919	0.833	0.836	0.920	1.399



WARNING: Gray area represents antifreeze concentrations greater than 35% by weight and should be avoided due to the extreme performance penalty they represent.

Antifreeze Correction Example

Antifreeze solution is propylene glycol 20% by weight for the source and methanol 10% for the load. Determine the corrected heating at 30°F source and 80°F load as well as pressure drop at 30°F for an O50. Also, determine the corrected cooling at 90°F source and 50°F load.

The corrected heating capacity at 30°F/80°F would be:

$$46,700 \text{ MBTUH} \times 0.913 \times 0.985 = 41,998 \text{ MBTUH}$$

The corrected cooling capacity at 90°F/50°F would be:

$$44,200 \times 0.969 \times 0.962 = 41,202 \text{ MBTUH}$$

The corrected pressure drop at 30°F and 15 GPM would be:

$$5.2 \text{ psi} \times 1.270 = 6.60 \text{ psi}$$

Troubleshooting Guideline for Refrigerant Circuit

The chart below will assist in determining if measurements taken at the unit are within factory specifications and aid in accurate diagnosis (SYMPTOM) and repair. The chart is general in nature and represents whether a symptom would result in normal, high, or low readings from the typical operating range.

Symptom	Head Pressure	Suction Pressure	Compressor Amp Draw	Superheat	Subcooling	Water Temp. Differential
Under Charged System (Possible Leak)	Low	Low	Low	High	Low	Low
Over Charged System	High	High	High	Normal	High	Normal
Low Water Flow Evaporator	Low/Normal	Low/Normal	Low	Low	High	High
Low Water Flow Condensor	High	High	High	High	Low	High
High Water Flow Evaporator	Normal	Low	Normal	High	Normal	Low
High Water Flow Condensor	Low	Low	Low	Low	High	Low
Restricted TXV (Check Service Advisory)	High	Low	Normal/Low	High	High	Low
Insufficient Compressor (Possible Bad Valves)	Low	High	Low	High	Normal/High	Low
TXV - Bulb Loss of Charge	Low	Low	Low	High	High	Low
Scaled Coaxial Heat Exchanger Evaporator	Low	Low	Low	Normal/Low	High	Low
Scaled Coaxial Heat Exchanger Condensor	High	High	High	Normal/Low	Low	Low
Restricted Filter Drier	Check temperature difference (delta T) across filter drier.					

7/8/14

Heat of Rejection

	Source EST °F	Source GPM	Load Flow-4 GPM				Load Flow-5.5 GPM				Load Flow-7 GPM				
			ELT 50°F	ELT 70°F	ELT 90°F	ELT 110°F	ELT 50°F	ELT 70°F	ELT 90°F	ELT 110°F	ELT 50°F	ELT 70°F	ELT 90°F	ELT 110°F	
024	30	4.0	30.0	32.5	35.0	37.5	30.7	33.1	35.4	37.8	31.4	33.6	35.9	38.1	
		5.5	29.3	31.3	33.3	35.3	29.8	31.7	33.7	35.6	30.3	32.2	34.0	35.9	
		7.0	28.5	30.0	31.6	33.1	28.8	30.4	31.9	33.4	29.2	30.7	32.2	33.7	
	50	4.0	29.7	33.9	38.2	42.4	30.7	34.7	38.7	42.7	31.7	35.5	39.3	43.1	
		5.5	29.3	33.3	37.2	41.2	30.0	33.9	37.7	41.5	30.7	34.5	38.2	41.9	
		7.0	28.9	32.6	36.3	40.0	29.4	33.0	36.7	40.3	29.8	33.4	37.1	40.7	
	70	4.0	29.4	35.3	41.3		30.7	36.4	42.0		32.0	37.4	42.8		
		5.5	29.4	35.3	41.1		30.3	36.0	41.8		31.2	36.8	42.4		
		7.0	29.4	35.2	41.0	46.8	29.9	35.7	41.5	47.3	30.4	36.2	41.9	47.7	
	90	4.0	27.8	34.3			29.1	35.5			30.5	36.6			
		5.5	27.6	34.1			28.7	35.0			29.7	35.9			
		7.0	27.5	33.9			28.2	34.5			29.0	35.2			
	110	4.0	26.2	33.3			27.6	34.5			28.9	35.8			
		5.5	25.9	32.9			27.1	34.0			28.2	35.0			
		7.0	25.6	32.5			26.5	33.4			27.5	34.2			
	048	Source EST °F	Source GPM	Load Flow-8 GPM				Load Flow-11.5 GPM				Load Flow-15 GPM			
				ELT 50°F	ELT 70°F	ELT 90°F	ELT 110°F	ELT 50°F	ELT 70°F	ELT 90°F	ELT 110°F	ELT 50°F	ELT 70°F	ELT 90°F	ELT 110°F
		30	8.0	58.7	63.0	67.4	71.7	60.7	64.4	68.2	72.0	62.6	65.8	69.0	72.3
11.5			59.5	62.8	66.1	69.4	61.3	64.0	66.8	69.6	63.0	65.2	67.5	69.7	
15.0			60.3	62.6	64.9	67.2	61.8	63.6	65.4	67.2	63.4	64.6	65.9	67.1	
50		8.0	57.4	65.0	72.6	80.3	59.7	66.9	74.1	81.4	62.0	68.8	75.6	82.5	
		11.5	58.2	65.2	72.3	79.3	60.2	66.6	73.0	79.4	62.2	67.9	73.7	79.4	
		15.0	59.1	65.5	71.9	78.4	60.7	66.3	71.8	77.4	62.4	67.1	71.7	76.4	
70		8.0	56.0	67.0	77.9		58.7	69.4	80.1		61.3	71.8	82.3		
		11.5	56.9	67.7	78.4		59.1	69.2	79.2		61.4	70.6	79.9		
		15.0	57.8	68.4	78.9	89.5	59.6	68.9	78.2	87.6	61.4	69.5	77.5	85.6	
90		8.0	54.1	65.7	77.3		56.1	67.5	78.9		58.0	69.3	80.6		
		11.5	54.5	65.7	76.8		56.3	67.1	77.9		58.0	68.5	79.0		
		15.0	55.0	65.7	76.4		56.5	66.7	76.9		58.1	67.7	77.4		
110		8.0	52.2	64.4			53.5	65.6			54.7	66.8			
		11.5	52.2	63.7			53.4	65.0			54.6	66.6			
		15.0	52.1	63.0			53.3	64.5			54.5	66.0			
060		Source EST °F	Source GPM	Load Flow-9 GPM				Load Flow-13.5 GPM				Load Flow-18 GPM			
	ELT 50°F			ELT 70°F	ELT 90°F	ELT 110°F	ELT 50°F	ELT 70°F	ELT 90°F	ELT 110°F	ELT 50°F	ELT 70°F	ELT 90°F	ELT 110°F	
	30	9.0	68.1	75.4	82.8	90.2	70.3	77.1	83.9	90.7	72.4	78.7	85.0	91.3	
		13.5	66.9	72.3	77.3	83.0	69.6	74.2	78.8	83.3	72.3	76.1	79.9	83.7	
		18.0	65.7	69.1	72.4	75.8	68.9	71.2	73.6	75.9	72.1	73.4	74.8	76.1	
	50	9.0	66.3	77.7	89.0	100.4	68.6	79.6	90.5	101.4	71.0	81.5	92.0	102.4	
		13.5	65.9	75.7	85.4	95.2	68.4	77.7	87.0	96.3	71.0	79.8	88.6	97.5	
		18.0	65.2	73.6	81.8	89.9	68.2	75.9	83.5	91.2	71.0	78.1	85.3	92.5	
	70	9.0	64.5	79.9	95.3		67.0	82.1	97.1		69.5	84.2	98.9		
		13.5	64.9	79.1	93.2		67.3	81.3	95.3		69.7	83.5	97.4		
		18.0	65.2	78.2	91.2	104.1	67.5	80.5	93.5	106.5	69.9	82.9	95.8	108.8	
	90	9.0	61.8	76.5	91.2		63.8	78.4	93.1		65.8	80.4	95.0		
		13.5	62.0	76.0	90.0		63.9	78.0	92.1		65.8	90.0	94.2		
		18.0	62.2	75.5	88.8		64.0	77.5	91.1		65.8	79.6	93.3		
	110	9.0	59.0	73.1			60.5	74.8			62.1	76.6			
		13.5	59.1	72.9			60.5	74.7			61.9	76.5			
		18.0	59.2	72.8			60.5	74.6			61.8	76.3			

Heat of Extraction

Source EST °F	Source GPM	Load Flow-4 GPM				Load Flow-5.5 GPM				Load Flow-7 GPM					
		ELT 60°F	ELT 80°F	ELT 100°F	ELT 120°F	ELT 60°F	ELT 80°F	ELT 100°F	ELT 120°F	ELT 60°F	ELT 80°F	ELT 100°F	ELT 120°F		
024	25	4.0													
		5.5													
		7.0	16.5	14.3	12.2	10.0	16.7	14.6	12.4	10.2	16.9	14.8	12.6	10.5	
	30	4.0	18.8	16.2	13.5	10.9	18.4	16.0	13.6	11.2	18.0	15.8	13.6	11.4	
		5.5	18.7	16.2	13.7	11.2	18.8	16.3	13.9	11.5	18.8	16.4	14.1	11.7	
		7.0	18.6	16.3	13.9	11.6	19.1	16.7	14.2	11.8	19.6	17.0	14.5	12.0	
	50	4.0	24.4	21.8	19.1	16.5	24.3	21.8	19.3	16.8	24.2	21.8	19.5	17.2	
		5.5	24.8	22.2	19.6	16.9	24.9	22.4	19.9	17.3	25.0	22.6	20.1	17.7	
		7.0	25.3	22.6	20.0	17.3	25.6	23.0	20.4	17.8	25.9	23.3	20.8	18.2	
	70	4.0	30.0	27.4	24.7	22.1	30.2	27.6	25.1	22.5	30.3	27.8	25.4	22.9	
		5.5	31.0	28.2	25.4	22.6	31.1	28.5	25.8	23.1	31.3	28.7	26.2	23.6	
		7.0	31.9	29.0	26.1	23.1	32.1	29.3	26.5	23.8	32.3	29.6	27.0	24.4	
90	4.0	36.0	33.8			36.4	34.2			36.8	34.6				
	5.5	37.0	34.9			37.4	35.2			37.7	35.6				
	7.0	38.0	35.9			38.4	36.3			38.7	36.6				
048	25	8.0	Load Flow-8 GPM				Load Flow-11.5 GPM				Load Flow-15 GPM				
			ELT 60°F	ELT 80°F	ELT 100°F	ELT 120°F	ELT 60°F	ELT 80°F	ELT 100°F	ELT 120°F	ELT 60°F	ELT 80°F	ELT 100°F	ELT 120°F	
	30	8.0	35.6	31.6	27.5	23.4	35.6	31.6	27.6	23.6	35.6	31.7	27.7	23.8	
		11.5	37.2	32.7	28.3	23.8	37.4	32.9	28.5	24.0	37.6	33.1	28.7	24.2	
		15.0	38.7	33.9	29.0	24.2	39.1	34.2	29.3	24.4	39.5	34.6	29.6	24.7	
	50	8.0	48.3	43.1	38.0	32.9	48.2	43.2	38.2	33.2	48.2	3.3	38.4	33.5	
		11.5	50.2	44.7	39.1	33.5	50.3	44.8	39.4	33.9	50.3	45.0	39.6	34.2	
		15.0	52.2	46.2	40.2	34.2	52.3	46.4	40.5	34.6	52.4	46.6	40.8	35.0	
	70	8.0	60.9	54.7	48.5	42.3	60.9	54.8	48.8	42.8	60.8	55.0	49.1	43.3	
		11.5	63.3	56.6	50.0	43.3	63.2	56.7	50.3	43.8	63.1	56.8	50.5	44.3	
		15.0	65.8	58.6	51.4	44.3	65.5	58.6	51.7	44.8	65.3	58.6	51.9	45.2	
	90	8.0	72.4	65.0	57.6			68.0	62.3	56.6			63.6	59.6	55.6
		11.5	74.1	67.0	59.9			70.7	64.8	58.9			67.4	62.7	58.0
		15.0	75.8	69.0	62.2			73.5	67.4	61.3			71.2	65.8	60.3
	060	25	9.0	Load Flow-9 GPM				Load Flow-13.5 GPM				Load Flow-18 GPM			
				ELT 60°F	ELT 80°F	ELT 100°F	ELT 120°F	ELT 60°F	ELT 80°F	ELT 100°F	ELT 120°F	ELT 60°F	ELT 80°F	ELT 100°F	ELT 120°F
30		9.0	41.2	35.9	30.6	25.3	41.7	36.5	31.2	26.0	42.2	37.0	31.8	26.6	
		13.5	41.9	36.6	31.3	26.0	42.5	37.2	31.9	26.7	43.0	37.8	32.6	27.4	
		18.0	42.7	37.3	32.0	26.6	43.3	38.0	32.7	27.4	43.8	38.6	33.4	28.1	
50		9.0	56.2	50.0	43.9	37.7	56.9	50.7	44.6	38.5	57.5	51.4	45.3	39.2	
		13.5	57.9	51.7	45.4	39.2	58.6	52.4	46.2	40.0	59.2	53.1	46.9	40.8	
		18.0	59.7	53.3	47.0	40.6	60.3	54.0	47.8	41.5	60.9	54.7	48.5	42.3	
70		9.0	71.1	64.1	57.1	50.2	72.0	65.0	58.0	51.0	72.9	65.8	58.8	51.8	
		13.5	73.9	66.7	59.6	52.4	74.7	67.6	60.4	53.3	75.4	68.4	61.3	54.2	
		18.0	76.7	69.4	62.0	54.6	77.4	70.1	62.9	55.6	78.0	70.9	63.7	56.6	
90		9.0	85.5	77.8			83.6	77.1			81.6	76.3			
		13.5	87.3	79.4	71.4			85.0	78.4	71.9			82.7	77.5	72.3
		18.0	89.2	81.0	72.8			86.5	79.8	73.2			83.8	78.7	73.6

Water Quality

General

Water-to-water heat pumps may be successfully applied in a wide range of residential and light commercial applications. It is the responsibility of the system designer and installing contractor to ensure that acceptable water quality is present and that all applicable codes have been met in these installations. Failure to adhere to the guidelines in the water quality table could result in loss of warranty.

Application

These heat pumps are not intended for direct coupling to swimming pools and spas. If used for this type of application, a secondary heat exchanger must be used. Failure to supply a secondary heat exchanger for this application will result in warranty exclusion for primary heat exchanger corrosion or failure.

Water Treatment

Do not use untreated or improperly treated water. Equipment damage may occur. The use of improperly treated or untreated water in this equipment may result in scaling, erosion, corrosion, algae or slime. The services of a qualified water treatment specialist should be engaged to determine what treatment, if any, is required. The product warranty specifically excludes liability for corrosion, erosion or deterioration of equipment.

The heat exchangers and water lines in the units are copper or cupronickel tube. There may be other materials in the building's piping system that the designer may need to take into consideration when deciding the parameters of the water quality.

If an antifreeze or water treatment solution is to be used, the designer should confirm it does not have a detrimental effect on the materials in the system.

Contaminated Water

In applications where the water quality cannot be held to prescribed limits, the use of a secondary or intermediate heat exchanger is recommended to separate the unit from the contaminated water.

The following table outlines the water quality guidelines for unit heat exchangers. If these conditions are exceeded, a secondary heat exchanger is required. Failure to supply a secondary heat exchanger where needed will result in a warranty exclusion for primary heat exchanger corrosion or failure.



WARNING: Must have intermediate heat exchanger when used in pool and spa applications.

Water Quality Guidelines

Material		Copper	90/10 Cupronickel	316 Stainless Steel
pH	Acidity/Alkalinity	7 - 9	7 - 9	7 - 9
Scaling	Calcium and Magnesium Carbonate	(Total Hardness) less than 350 ppm	(Total Hardness) less than 350 ppm	(Total Hardness) less than 350 ppm
Corrosion	Hydrogen Sulfide	Less than 0.5 ppm (rotten egg smell appears at 0.5 ppm)	10 - 50 ppm	Less than 1 ppm
	Sulfates	Less than 125 ppm	Less than 125 ppm	Less than 200 ppm
	Chlorine	Less than 0.5 ppm	Less than 0.5 ppm	Less than 0.5 ppm
	Chlorides	Less than 20 ppm	Less than 125 ppm	Less than 300 ppm
	Carbon Dioxide	Less than 50 ppm	10 - 50 ppm	10 - 50 ppm
	Ammonia	Less than 2 ppm	Less than 2 ppm	Less than 20 ppm
	Ammonia Chloride	Less than 0.5 ppm	Less than 0.5 ppm	Less than 0.5 ppm
	Ammonia Nitrate	Less than 0.5 ppm	Less than 0.5 ppm	Less than 0.5 ppm
	Ammonia Hydroxide	Less than 0.5 ppm	Less than 0.5 ppm	Less than 0.5 ppm
	Ammonia Sulfate	Less than 0.5 ppm	Less than 0.5 ppm	Less than 0.5 ppm
Iron Fouling (Biological Growth)	Total Dissolved Solids (TDS)	Less than 1000 ppm	1000 - 1500 ppm	1000 - 1500 ppm
	LSI Index	+0.5 to -0.5	+0.5 to -0.5	+0.5 to -0.5
Iron Fouling (Biological Growth)	Iron, FE ²⁺ (Ferrous) Bacterial Iron Potential	< 0.2 ppm	< 0.2 ppm	< 0.2 ppm
	Iron Oxide	Less than 1 ppm, above this level deposition will occur	Less than 1 ppm, above this level deposition will occur	Less than 1 ppm, above this level deposition will occur
Erosion	Suspended Solids	Less than 10 ppm and filtered for max. of 600 micron size	Less than 10 ppm and filtered for max. of 600 micron size	Less than 10 ppm and filtered for max. of 600 micron size
	Threshold Velocity (Fresh Water)	< 6 ft/sec	< 6 ft/sec	< 6 ft/sec

NOTES: Grains = ppm divided by 17
mg/L is equivalent to ppm

2/22/12

Operating Parameters

Heating Mode

Entering Load Temp (°F)	Entering Source Temp (°F)	Suction Pressure (psig)	Discharge Pressure (psig)	Superheat (°F)	Subcooling (°F)
60	20	50-67	185-227	8-16	5-15
	30	64-82	198-235	7-14	6-14
	50	91-113	206-245	7-14	6-12
	70	121-144	215-255	8-19	5-15
	90	139-167	220-275	14-26	8-12
80	20	52-69	273-316	8-16	7-15
	30	67-84	283-323	10-12	7-18
	50	95-125	292-335	12-14	8-16
	70	118-148	301-346	14-18	8-16
	90	141-179	309-363	14-26	8-16
100	20	53-71	359-405	8-10	6-14
	30	74-85	368-411	10-12	7-15
	50	61-126	378-425	12-14	7-15
	70	119-152	388-438	14-18	3-12
	90	144-191	400-452	14-22	3-12
120	20	56-74	445-495	8-18	4-16
	30	71-87	454-500	6-16	5-17
	50	103-128	464-515	5-17	5-15
	70	121-156	475-530	6-16	4-15
	90	Operation not recommended			

Notes: Operating parameters at 3 gpm/ton source and load flow. Consult the Capacity Tables for each model for normal allowable operating conditions. Some of the conditions shown above are outside of the compressor operational limits for specific models.

Cooling Mode

Entering Load Temp (°F)	Entering Source Temp (°F)	Suction Pressure (psig)	Discharge Pressure (psig)	Superheat (°F)	Subcooling (°F)
50	30	84-99	125-160	12-22	2-15
	50	89-107	181-214	10-19	4-15
	70	98-115	238-268	5-15	6-16
	90	97-119	325-367	6-15	8-16
	110	101-122	415-465	8-16	10-19
70	30	84-106	121-163	15-20	3-6
	50	99-125	184-223	11-15	6-9
	70	114-143	247-273	11-15	9-12
	90	121-151	334-381	8-12	12-14
90	30	87-113	121-166	15-20	3-6
	50	111-143	187-233	11-15	6-9
	70	124-158	256-294	11-15	9-12
	90	147-168	344-395	8-12	12-14
110	30	94-121	115-170	55-65	2-20
	50	123-161	190-243	41-52	4-18
	70	154-200	265-315	21-38	8-19
	90	Operation not recommended			

Notes: Operating parameters at 3 gpm/ton source and load flow. Consult the Capacity Tables for each model for normal allowable operating conditions. Some of the conditions shown above are outside of the compressor operational limits for specific models.

10/11/24

Pressure Drop

Pressure Drop Table

Model	GPM	Pressure Drop (psi)				
		30°F	60°F	80°F	100°F	120°F
O24R*	4.0	0.9	0.7	0.6	0.5	0.4
	5.5	2.0	1.9	1.8	1.7	1.5
	7.0	3.2	3.0	2.9	2.8	2.6
	8.5	4.4	4.2	4.0	3.8	3.7
O48H/R	8.0	1.7	1.4	1.4	1.3	1.3
	11.5	3.6	3.4	3.2	3.0	2.8
	15.0	5.6	5.4	5.0	4.6	4.2
	18.5	8.3	8.1	7.6	7.2	6.8
O60H/R	9.0	1.4	1.1	1.0	1.0	0.9
	13.5	4.2	3.9	3.5	3.1	2.7
	18.0	6.9	6.7	6.0	5.2	4.5
	22.5	10.7	10.5	10.0	9.4	8.7

Note: Temperatures are Entering Water Temperatures 10/11/24

*Domestic water heating units source side pressure drop and reversible units load and source pressure drop.

Heating Only Load Side Pressure Drop Table

Model	GPM	Pressure Drop (psi)			
		60°F	80°F	100°F	120°F
O24H	4.0	1.3	1.3	1.2	1.2
	5.5	3.0	2.9	2.8	2.7
	7.0	4.6	4.4	4.3	4.1
	8.5	6.7	6.5	6.4	6.2

Note: Temperatures are Entering Water Temperatures

10/11/24

Operating Limits

Operating Limits	Cooling		Heating	
	°F	°C	°F	°C
Source Side Water Limits				
Minimum Entering Water	30	-1.1	20	-6.7
Normal Entering Water	85	29.4	60	15.6
Maximum Entering Water	110	43.3	90	32.2
Load Side Water Limits				
Minimum Entering Water	50	10.0	60	15.6
Normal Entering Water	60	15.6	100	37.8
Maximum Entering Water	90	32.2	120	48.9

NOTES: Minimum/maximum limits are only for start-up conditions, and are meant for bringing the space up to occupancy temperature. Units are not designed to operate at the minimum/maximum conditions on a regular basis. The operating limits are dependant upon three primary factors: 1) entering source temperature, 2) entering load temperature, and 3) flow rate (gpm). When any of the factors are at the minimum or maximum levels, the other two factors must be at the normal level for proper and reliable unit operation. Consult the Capacity Tables for each model to determine allowable normal operating conditions. Units are not designed for outdoor installation.

Flow Rates

Source Flow Rates

Model	Minimum Open Loop Flow Rate	Minimum Closed Loop Flow Rate	Normal Load Flow Rate	Maximum Flow Rate
024	4.0	5.0	7.0	9.0
048	8.0	12.0	15.0	17.0
060	9.0	13.0	18.0	20.0

10/11/24

Load Flow Rates

Model	Minimum Load Flow Rate	Normal Load Flow Rate	Maximum Flow Rate
024	4.0	7.0	9.0
048	5.0	10.0	12.0
060	9.0	18.0	20.0

10/11/24

Aurora Control System

Aurora ‘Base’ Control

The Aurora ‘Base’ Control (ABC) System is a complete residential and commercial comfort system that brings all aspects of the HVAC system into one cohesive module network. The ABC features microprocessor control and HP, LP, condensate and freeze detection, over/under voltage faults, along with communicating thermostat capability for complete fault detection text at the thermostat.

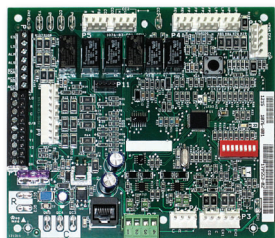

Aurora uses the Modbus communication protocol to communicate between modules. Each module contains the logic to control all features that are connected to the module. The Aurora ‘Base’ Control (ABC) has two Modbus channels. The first channel is configured as a master for connecting to devices such as a communicating thermostat, expansion board, or other slave devices. The second channel is configured as a slave for connecting the Aurora Interface Diagnostics Tool (AID Tool).

Aurora ‘Advanced’ Control

The Aurora ‘Advanced’ Control expands on the capability of the Aurora ‘Base’ Control (ABC) System by adding the Aurora Expansion Board (AXB). The additional features include compressor current monitoring, loop pump linking, intelligent hot water generator control, variable speed pump capability, and also allows for optional energy, refrigeration, and performance monitoring factory installed add-on sensor kits. The AXB also features a second field configurable accessory relay, and two home automation inputs that are AID configurable for different types of alarms from sump pumps to home security. The Smart Grid input is AID configurable with many options to react to Utility controlled relay operation for ON Peak optimization.

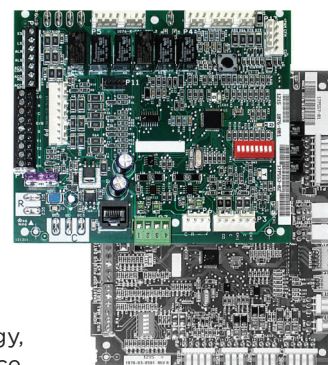

Aurora Control Features	Description	Aurora ‘Base’	Aurora ‘Advanced’
Microprocessor Compressor Control	Microprocessor control of compressor for timings with FP1, HP, LP, Condensate, assignable Acc relay	•	•
Advanced Microprocessor Features	Smart Grid, Home Automation Alarm Inputs, and Accessory2 Relay (HRV/ERV)	-	•
Base Hot Water Generator Operation	Compressor Contactor powers Hot Water Generator Pump with inline circuit breaker and thermostat limit.	•	See below
Advanced Hot Water Generator Control	Microprocessor and separate power relay for Hot Water Generator Pump with digital temperature monitoring and multiple HWG setpoint selection.	-	•
Base Loop Pump Control	Compressor Contactor powers Loop Pump with inline circuit breaker and no loop pump linking capability.	•	See below
Advanced Speed Pump Control	Microprocessor and separate power relay for loop pump and inline circuit breakers and loop pump linking.	-	•
Compressor Monitoring	Control monitors compressor starts for high current, missing leg etc.	-	•
Smart Grid/Utility Input	Allows simple input to externally enable of occupied/unoccupied mode for basic utility time of use programs.	-	Dry Contact x1
Home Automation Alarm Input	Allows simple input to signal sump, security, or smoke/CO sensor alarms from other home automation or security systems. The two inputs can be field configured to a number of options and logic.	-	Dry Contactx2
HAN/Smart Grid Com (AWL and Portal) Kit	Allows direct communication of the Aurora to Smart Meters, Home Automation Network and Internet.	-	Optional AWL

Aurora Control System

Service Device	Description	Aurora 'Base'	Aurora 'Advanced'
 <p>Aurora Interface and Diagnostics (AID) Tool</p>	<p>Allows setup, monitoring and troubleshooting of any Aurora Control.</p> <p>NOTE: Although the ABC has basic compatibility with all Aurora, new product features may not be available on older AID Tools. To simplify the basic compatibility ensure the version of AID is at least the same or greater than the ABC software version.</p>	For Service go to Aurora Toolbox for latest firmware version	For Service go to Aurora Toolbox for latest firmware version

Add On Control Feature Kits (field or factory installed)	Description	Aurora 'Base'	Aurora 'Advanced'
Geo Energy Monitoring Kit	Monitors realtime power consumption of compressor, aux heat and pump. AXB required.	-	Standard
Refrigeration Monitoring Kit	Monitors realtime pressures, temperatures, superheat, and subcooling. AXB required.	-	Optional Sensor Kit
Performance Monitoring Kit	Monitors water temperatures and water flow rate and calculates heat of extraction/rejection. AXB required.	-	Optional Sensor Kit
Data Logging (AWL) Kit	Allows data logging of up to 12 months. AXB required. Can also be temporarily installed for troubleshooting.	-	Optional
HAN/Smart Grid Com (AWL and Portal) Kit	Allows direct communication of the Aurora to Smart Meters, HAN, and internet. AXB required.	-	Optional
AXB Kit for advanced hot water generator control, flow center linking, variable speed pump	Added to ABC only units for key features of advanced hot water generator control and advanced loop control/linking.	Optional (Field Kit)	Standard

Add On Thermostats and Zoning	Description	Aurora 'Base'	Aurora 'Advanced'
HydroStat	Communicating controller for one hydronic heat pump.	Optional	Optional
HZO	Non-communicating controller for up to four heat pumps.	Optional	Optional
HZC	Non-communicating controller for one hydronic heat pump	Optional	Optional

Aurora Control System

Aurora 'Base' Control

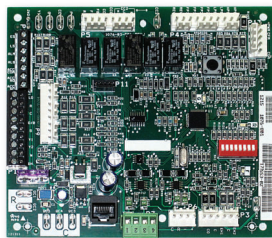

NOTE: Refer to the Aurora Base Control Application and Troubleshooting Guide and the Instruction Guide: Aurora Interface and Diagnostics (AID) Tool for additional information.

Control Features

- Random start at power up
- Anti-short cycle protection
- High and low pressure cutouts
- Loss of charge
- Water coil freeze detection
- Over/under voltage protection
- Load shed
- Emergency shutdown
- Diagnostic LED
- Test mode push button switch
- Alarm output
- Accessory output with N.O. and N.C.
- Modbus communication (master)
- Modbus communication (slave)

Field Selectable Options via Hardware

DIP Switch (SW1) – Test/Configuration Button (See SW1 Operation Table)

Test Mode

The control is placed in the test mode by holding the push button switch SW1 for 2 - 5 seconds. In test mode most of the control timings will be shortened by a factor of sixteen (16). LED3 (green) will flash at 1 second on and 1 second off. Additionally, when entering test mode LED1 (red) will flash the last lockout one time. Test mode will automatically time out after 30 minutes. Test mode can be exited by pressing and holding the SW1 button for 2 to 5 seconds or by cycling the power. **NOTE:** Test mode will automatically be exited after 30 minutes.

Reset Configuration Mode

The control is placed in reset configuration mode by holding the push button switch SW1 for 50 to 60 seconds. This will reset all configuration settings and the EEPROM back to the factory default settings. LED3 (green) will turn off when entering reset configuration mode. Once LED3 (green) turns off, release SW1 and the control will reset.

DIP Switch (SW2)

SW2-1 (Source) FP1 Selection – Low water coil temperature limit setting for freeze detection. On = 30°F; Off = 15°F.

SW2-2 (Load) FP2 Selection – On = 30°F; Off = 15°F

SW2-3 RV - O/B - thermostat type. Heat pump thermostats with “O” output in cooling or “B” output in Heating can be selected. On = O; Off = B.

SW2-4 Access Relay Operation (P2) and 2-5

Access Relay Operation	SW2-4	SW2-5
Cycle with Blower		n/a
Cycle with Compressor	OFF	OFF
Water Valve Slow Opening	ON	OFF
Cycle with Comm. T-stat Hum Cmd		n/a

Cycle with Blower - (Not used on water-to-water)

Cycle with Compressor - The accessory relay will cycle with the compressor output.

Water Valve Slow Opening - The accessory relay will cycle and delay both the blower and compressor output for 90 seconds.

SW2-6 CC Operation – selection of single or dual capacity compressor. On = Single Stage; Off = Dual Capacity

SW2-7 Lockout and Alarm Outputs (P2) – selection of a continuous or pulsed output for both the LO and ALM Outputs. On = Continuous; Off = Pulsed

SW2-8 *Future Use*

Alarm Jumper Clip Selection

From the factory, ALM is connected to 24 VAC via JW2. By cutting JW2, ALM becomes a dry contact connected to ALG.

Field Selectable Options via Software

(Selectable via the Aurora AID Tool)

Safety Features

The following safety features are provided to protect the compressor, heat exchangers, wiring and other components from damage caused by operation outside of design conditions.

Fuse – a 3 amp automotive type plug-in fuse provides protection against short circuit or overload conditions.

Anti-Short Cycle Protection – 4 minute anti-short cycle protection for the compressor.

Random Start – 5 to 80 second random start upon power up.

Aurora Control System

Fault Retry - In the fault condition, the control will stage off the outputs and then “try again” to satisfy the thermostat Y input call. Once the thermostat input calls are satisfied, the control will continue on as if no fault occurred. If 3 consecutive faults occur without satisfying the thermostat Y input call, then the control will go to Lockout mode.

Lockout - The Alarm output (ALM) and Lockout output (L) will be turned on. The fault type identification display LED1 (Red) shall flash the fault code. To reset lockout conditions with SW2-8 On, thermostat inputs “Y1”, “Y2”, and “W” must be removed for at least 3 seconds. To reset lockout conditions with SW2-8 Off, thermostat inputs “Y1”, “Y2”, “W”, and “DH” must be removed for at least 3 seconds. Lockout may also be reset by turning power off for at least 30 seconds or by enabling the emergency shutdown input for at least 3 seconds.

High Pressure - fault is recognized when the Normally Closed High Pressure Switch, P4-9/10 opens, no matter how momentarily. The High Pressure Switch is electrically in series with the Compressor Contactor and serves as a hard-wired limit switch if an overpressure condition should occur.

Low Pressure - fault is recognized when the Normally Closed Low Pressure Switch, P4-7/8 is continuously open for 30 seconds. Closure of the LPS any time during the 30 second recognition time restarts the 30 second continuous open requirement. A continuously open LPS shall not be recognized during the 2 minute startup bypass time.

Loss of Charge - fault is recognized when the Normally Closed Low Pressure Switch, P4-7/8 is open prior to the compressor starting.

Freeze Detection (Source Coax) - set points shall be either 30°F or 15°F. When the thermistor temperature drops below the selected set point, the control shall begin counting down the 30 seconds delay. If the thermistor value rises above the selected set point, then the count should reset. The resistance value must remain below the selected set point for the entire length of the appropriate delay to be recognized as a fault. This fault will be ignored for the initial 2 minutes of the compressor run time.

Freeze Detection (Load Coax) - uses the FP2 input to protect against ice formation on the coax. The FP2 input will operate exactly like FP1.

Over/Under Voltage Shutdown - An over/under voltage condition exists when the control voltage is outside the range of 18 VAC to 30 VAC. If the over/under voltage shutdown lasts for 15 minutes, the lockout and alarm relay will be energized. Over/under voltage shutdown is self-resetting in that if the voltage comes back within range of 18 VAC to 30 VAC for at least 0.5 seconds, then normal operation is restored.

Operation Description

Power Up - The unit will not operate until all the inputs and safety controls are checked for normal conditions. The unit has a 5 to 80 second random start delay at power up. Then the compressor has a 4 minute anti-short cycle delay after the random start delay.

Standby In standby mode, Y1, Y2, W, DH, and G are not active. Input O may be active. The blower and compressor will be off.

Heating Operation

Heating, 1st Stage (Y1) - The compressor is energized 10 seconds after the Y1 input is received.

Cooling Operation

In all cooling operations, the reversing valve directly tracks the O input. Thus, anytime the O input is present, the reversing valve will be energized.

Cooling, 1st Stage (Y1, O) - The compressor is energized 10 seconds after the Y1 input is received.

Emergency Shutdown - Four (4) seconds after a valid ES input, P2-7 is present, all control outputs will be turned off and remain off until the emergency shutdown input is no longer present. The first time that the compressor is started after the control exits the emergency shutdown mode, there will be an anti-short cycle delay followed by a random start delay. Input must be tied to common to activate.

Load Shed - The LS input disables all outputs with the exception of the blower output. When the LS input has been cleared, the anti-short cycle timer and random start timer will be initiated. Input must be tied to common to activate.

Aurora Control System

Aurora 'Base' Control LED Displays

These three LEDs display the status, configuration, and fault codes for the control. These can also be read in plain English via the Aurora AID Tool.

Status LED (LED3, Green)

Description of Operation	Fault LED, Green
Normal Mode	ON
Control is Non-functional	OFF
Test Mode	Slow Flash
Lockout Active	Fast Flash
Dehumidification Mode	Flash Code 2
(Future Use)	Flash Code 3
(Future Use)	Flash Code 4
Load Shed	Flash Code 5
ESD	Flash Code 6
(Future Use)	Flash Code 7

Fault LED (LED1, Red)

Red Fault LED	LED Flash Code*	Lockout	Reset/Remove
Normal - No Faults	OFF	-	
Fault - Input	1	No	Auto
Fault - High Pressure	2	Yes	Hard or Soft
Fault - Low Pressure	3	Yes	Hard or Soft
Fault - Freeze Detection FP2	4	Yes	Hard or Soft
Fault - Freeze Detection FP1	5	Yes	Hard or Soft
Fault - Condensate Overflow	7	Yes	Hard or Soft
Fault - Over/Under Voltage	8	No	Auto
Fault - FP1 & FP2 Sensor Error	11	Yes	Hard or Soft

NOTE: All codes >11 use long flash for tens digit and short flash for the ones digit. 20, 30, 40, 50, etc. are skipped.

ABC Control Board Layout

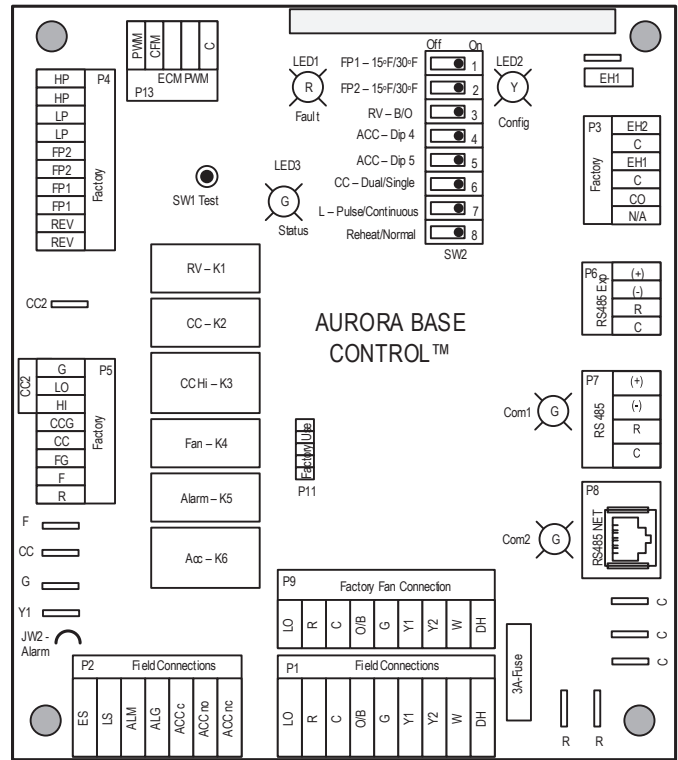

Aurora Interface and Diagnostics (AID) Tool

The Aurora Interface and Diagnostics (AID) Tool is a device that is a member of the Aurora network. The AID Tool is used to troubleshoot equipment which uses the Aurora control via Modbus RTU communication. The AID Tool provides diagnostics, fault management, ECM setup, and system configuration capabilities to the Aurora family of controls. An AID Tool is recommended, although not required, for ECM airflow settings. The AID Tool simply plugs into the exterior of the cabinet in the AID Tool port.



Aurora Control System

Aurora 'Advanced' Control Features

The Aurora 'Advanced' Control system expands on the capability of the Aurora 'Base' Control (ABC) by adding the Aurora Expansion Board (AXB). All of the preceding features of the Aurora 'Base' Control are included. The following control description is of the additional features and capability of the Aurora advanced control.

It is highly recommended the installing/servicing contractor obtain an Aurora Interface and Diagnostic Tool (AID) and specialized training before attempting to install or service an Aurora 'Advanced' control system.

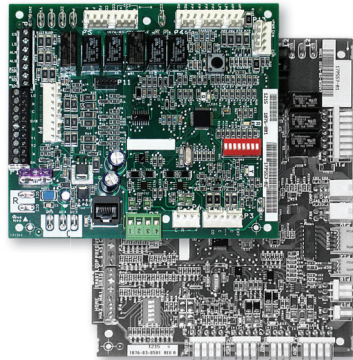

The additional AXB features include the following:

AXB DIP Switch

DIP 1 - ID: This is the AXB ModBus ID and should always read On.

DIP 2 & 3 - Future Use

DIP 4 & 5 - Accessory Relay2: A second, DIP configurable, accessory relay is provided that can be cycled with the compressor 1 or 2, blower, or the Dehumidifier (DH) input. This is to complement the Accessory 1 Relay on the ABC board.

Position	DIP 4	DIP 5	Description
1	ON	ON	Cycles with Fan or ECM (or G)
2	OFF	ON	Cycles with CC1 first stage of compressor or compressor spd 6
3	ON	OFF	Cycles with CC2 second stage of compressor or compressor spd 7-12
4	OFF	OFF	Cycles with DH input from ABC board

Advanced Hot Water Generator Control (Domestic Hot Water Option)

In lieu of the 'Base Hot Water Generator Control', the Advanced features an AID Tool selectable temperature limit and microprocessor control of the process. This will maximize hot water generation and prevent undesirable energy use. An alert will occur when the hot water input temperature is at or above setpoint (100°F - 140°F) for 30 continuous seconds (130°F is the default setting). This alert will appear as an E15 on the AID Tool and the hot water pump de-energizes. Hot water pump operations resume on the next compressor cycle or after 15 minutes of continuous compressor operation during the current thermostat demand cycle. Since compressor hot gas temperature is dependent on loop temperature in cooling mode, loop temperatures may be too low to allow proper heating of water. The control will monitor water and refrigerant temperatures to determine if conditions are satisfactory for heating water. LED1 (red LED) will flash code 15 when the DHW limit is reached and when conditions are not favorable for water heating. Error code 15 will also be displayed on the AID Tool in the fault screen. This flash code is a noncritical alert and does not necessarily indicate a problem.

Compressor Monitoring

The AXB includes two current transducers to monitor the compressor current and starting characteristics. Open circuits or welded contactor faults will be detected. A fault will produce an E10 code.

Loop Pump Linking

This input and output are provided so that two units can be linked together with a common flow center. When either unit has a call for loop pump, both unit's loop pump relays and variable speed pumps are energized. The flow center then can simply be wired to either unit. The output from one unit should be routed to the input of the other. If daisy chained up to 16 heat pumps can be wired and linked together in this fashion.

Advanced Communication Ports

Communication ports P6 and P8 will provide future expansion via dedicated protocols. These are for future use.

Aurora Control System

Smart Grid-On Peak (SG) Input

The 'On Peak' input was designed to allow utilities to utilize simple radio controlled switches to control the On Electric Peak behavior of the 5 and 7 Series Geothermal Heat Pumps. With a closed contact signal, this input will limit the operation and thus the power consumption of the unit by one of the below selections. The AID Tool will allow configuration of this input for the action of:

- No Action
- Disable compressor operation until removed
- Go to On Peak thermostat settings until removed [Requires Com T-Stat] (Future Release)
- Compressor limited to 50% or low cap until removed [dual capacity or variable speed only] (Future Release)
- Disable compressor operation for 1/2 hr (can be removed immediately) (Future Release)

Then Flash Code 7 on the Green LED for the 'On Peak' mode. And On Peak will display on communicating thermostats.

Home Automation 1 and 2 Inputs

The Home automation inputs are simple closed contact inputs that will trigger an AID Tool and thermostat alert for the homeowner. These would require optional sensors and or equipment for connection to the AXB board. With two inputs two different sensors can be selected. The selected text will then be displayed on the AID Tool and communicating thermostats. These events will NOT alter functionality or operation of the heat pump/accessories and is for homeowner/service notification only.

Home Automation 1 - E23 HA1

With a closed dry contact signal, this input will cause an alarm and Alert Code 23 to indicate on the stat or flash on ABC. The AID Tool will allow configuration of this input between the following selections:

- No Action
- Home Automation Fault [no lockout info only]
 - Output from home automation system
- Security Alarm [no lockout info only]
 - Output from home security
- Sump Alarm Fault [no lockout info only]
 - Switch output from sump sensor
- Smoke/CO Alarm Fault [no lockout info only]
 - Switch output from Smoke/CO sensor
- Dirty Filter Alarm [no lockout info only]
 - Output from dirty filter sensor

Home Automation 2 - E24 HA2

With a closed dry contact signal, this input will cause an alarm and Alert Code 24 to indicate on the stat or flash on ABC. The AID Tool will allow configuration of this input between the following selections:

- No Action
- Home Automation Fault [no lockout info only]
 - Output from home automation system
- Security Alarm [no lockout info only]
 - Output from home security
- Sump Alarm Fault [no lockout info only]
 - Switch output from sump sensor
- Smoke/CO Alarm Fault [no lockout info only]
 - Switch output from Smoke/CO sensor
- Dirty Filter Alarm [no lockout info only]
 - Output from dirty filter sensor

Monitoring Sensor Kits

Energy Monitoring (Standard Sensor Kit)

The Energy Monitoring Kit includes two current transducers (load pump and electric heat) added to the existing two compressor sensors so that the complete power usage of the heat pump can be measured. The AID Tool provides a line voltage calibration procedure to improve the accuracy, and a power adjustment setting that allows the compressor power to be adjusted to match the units line voltage using the provided tables. This information can be displayed on the AID Tool.

Refrigerant Monitoring (optional sensor kit)

The optional Refrigerant Monitoring Kit includes two pressure transducers, and three temperature sensors, heating liquid line, suction temperature and existing cooling liquid line (FPI). These sensors allow the measurement of discharge and suction pressures, suction and liquid line temperatures as well as superheat and subcooling. This information will only be displayed on the AID Tool.

Performance Monitoring (optional sensor kit)

The optional Performance Monitoring Kit includes three temperature sensors, source entering, source leaving, and leaving load water, and a water flow rate sensor. With this kit heat of extraction and rejection will be calculated. This requires configuration using the AID Tool for selection of water or antifreeze.

Single Speed Power Adjustment

Model	Voltage		
	208	230	250
024	0.99	0.99	0.95
048	0.99	0.97	0.9
060	0.98	0.96	0.87

Aurora Control System

Aurora 'Advanced' Control LED Displays

These three LEDs display the status, configuration, and fault codes for the control. These can also be read in plain English via the Aurora AID Tool.

Status LED (LED3, Green)

Description of Operation	Fault LED, Green
Normal Mode	ON
Control is Non-functional	OFF
Test Mode	Slow Flash
Lockout Active	Fast Flash
Dehumidification Mode	Flash Code 2
Load Shed	Flash Code 5
Emergency Shutdown	Flash Code 6
On Peak Mode	Flash Code 7
(Future Use)	Flash Code 8
(Future Use)	Flash Code 9

Configuration LED (LED2, Yellow)

Description of Operation	Configuration LED, Yellow
No Software Overwritten	ECM Setting
DIP Switch Overwritten	Slow Flash
ECM Configuration Mode	Fast Flash
Reset Configuration Mode	OFF

Fault LED (LED1, Red)

Red Fault LED		LED Flash Code*	Lockout	Reset/Remove	Fault Condition Summary
ABC & AXB Basic Faults	Normal - No Faults	Off			
	Fault-Input	1	No	Auto	Tstat input error. Autoreset upon condition removal.
	Fault-High Pressure	2	Yes	Hard or Soft	HP switch has tripped (>600 psi)
	Fault-Low Pressure	3	Yes	Hard or Soft	Low Pressure Switch has tripped (<40 psi for 30 continuous sec.)
	Fault-Freeze Detection FP2	4	Yes	Hard or Soft	Freeze protection sensor has tripped (<15 or 30 degF for 30 continuous sec.)
	Fault-Freeze Detection FP1	5	Yes	Hard or Soft	Freeze protection sensor has tripped (<15 or 30 degF for 30 continuous sec.)
	Fault-Loss of Charge	6	Yes	Hard or Soft	Low Pressure Switch open prior to compressor start (UPC Only)
	Fault-Condensate Overflow	7	Yes	Hard or Soft	Condensate switch has shown continuity for 30 continuous sec.
	Fault-Over/Under Voltage	8	No**	Auto	Instantaneous Voltage is out of range. **Controls shut down until resolved.
	Fault-Compressor Monitor	10	Yes	Hard or Soft	Open Crkt, Run, Start or welded cont
	Fault-FP1 & 2 Snsr Error	11	Yes	Hard or Soft	If FP1 or 2 Sensor Err
	Non-CriticAXBSnsrErr	13	No	Auto	Any Other Sensor Err
	CriticAXBSnsrErr	14	Yes	Hard or Soft	Sensor Err for EEV or HW
	Alarm-HotWtr	15	No	Auto	HW over limit or logic lockout. HW pump deactivated.
	Fault-VarSpdPump	16	No	Auto	Alert is read from PWM feedback.
	Non-CritComErr	18	No	Auto	Any non-critical com error
	Fault-CritComErr	19	No	Auto	Any critical com error. Auto reset upon condition removal
	Alarm - Low Loop Pressure	21	No	Auto	Loop pressure is below 3 psi for more than 3 minutes
	Alarm - Home Automation 1	23	No	Auto	Closed contact input is present on Dig 2 input - Text is configurable
	Alarm - Home Automation 2	24	No	Auto	Closed contact input is present on Dig 3 input - Text is configurable
Fault - AXB EEV Error	25	Yes	Auto	AXB EEV Error	
ASB	ASB High Gas Concentration	81	Yes	Auto	High refrigerant gas concentration detected by ASB and gas sensor.
	ASB Sensor Problem	82	Yes	Auto	Gas sensor has issued a fault, lost communication, internal error
	Invalid System Config	97	Yes	Auto	ABC has not been configured for Refrigerant type, disch pr sensor type, or suct press sens.

Note:

*All codes >11 use long flash for tens digit and short flash for the ones digit. 20, 30, 40, 50 etc. will be skipped!

Alert' is a noncritical sensor or function that has failed. Normal operation of the heat pump is maintained but service is desired at some point.

Aurora Control System

Aurora now expands the Fault/Alarms in to several groups. Faults are system critical faults to the heat pump and will cause a Lockout. Some are retried 3 times before locking out while others lockout out immediately. Consult the Fault Retries table before lockout for details. Alarms are designed solely to alert the customer and the dealer to alarms designed as an input only to the Aurora system. These alarms are not system critical. Errors are sensor/hardware errors that although may not be system critical, may need serviced for optimal features.

SafeMode - the system is still operational during safemode.

Summary Table of Faults, Alarm, and Errors

All lockouts and alarms are shown in the Status LED (LED1, Red) table with the associated codes visible on the thermostat, ABC Fault LED, and in text in the AID Tool.

Aurora Fault Codes (ABC-Red LED)

These fault codes generally will affect the operation of the heat pump and will cause a lockout.

E1, Fault Input - A Y1/Y2 style thermostat is providing a non-normal sequence of signals possibly caused by a bad thermostat wire or connection.

E2, High Pressure - Fault is recognized when the Normally Closed High Pressure Switch, P4-9/10 opens, no matter how momentarily. The High Pressure Switch is electrically in series with the Compressor Contactor and serves as a hardwired limit switch if an overpressure condition should occur.

E3, Low Pressure - Fault is recognized when the Normally Closed Low Pressure Switch, P4-7/8 is continuously open for 30 seconds. Closure of the LPS any time during the 30 second recognition time restarts the 30 second continuous open requirement. A continuously open LPS shall not be recognized during the 2 minute startup bypass time.

E3, Loss of Charge - Fault is recognized when the Normally Closed Low Pressure Switch, P4-7/8 is open prior to the compressor starting.

E4, Freeze Detection-Air Coil - Air Coil Freeze Detection will use the FP2 input to protect against ice formation on the air coil. The FP2 input will operate exactly like FP1 except that the set point is 30 degrees and is not field adjustable.

E5, Freeze Detection-Coax - Set points shall be either 30°F or 15°F. When the thermistor temperature drops below the selected set point, the control shall begin counting down the 30 seconds delay. If the thermistor value rises above the selected set point, then the count should reset. The resistance value must remain below the selected set point for the

entire length of the appropriate delay to be recognized as a fault. This fault will be ignored for the initial 2 minutes of the compressor run time.

E7, Condensate Overflow - Fault is recognized when the impedance between this line and 24 VAC common or chassis ground drops below 100K ohms for 30 seconds continuously.

E8, Over/Under Voltage Shutdown - An over/under voltage condition exists when the control voltage is outside the range of 18 VAC to 30 VAC. If the over/under voltage shutdown lasts for 15 minutes, the lockout and alarm relay will be energized. Over/under voltage shutdown is self-resetting in that if the voltage comes back within range of 18 VAC to 30 VAC for at least 0.5 seconds, then normal operation is restored.

E10, Compressor Monitoring - Fault is recognized when the compressor has an open circuit, potential welded contactor.

E11, FP1 Sensor Error - Fault is recognized when the impedance between this line and 24 VAC common or chassis.

E14, Critical AXB Sensor Error - Fault is recognized when a sensor faults that is critical to heat pump operation. These sensors would include the HW Temperature limit sensor.

E15, Alarm Hot Water - Fault is recognized when the hot water temperature sensor is either over the configured limit or the Aurora has determined the current conditions should disengage the hot water generation capability.

E16, Variable Speed Pump - Fault is recognized when the variable speed pump returns a fault code from its PWM feedback signal.

E19, Critical Communication Error - A critical communication error has occurred with a board that previously had been configured but now is not available for communication. Since this is critical to unit operation, the heat pump will be locked out with this fault displayed on the ABC board and the thermostat. The AID Tool should be used to view the configuration window and ascertain the status of all appropriate board communication. The fault displayed will be removed when the problem has been resolved or the unit is soft or hard reset.

E52, Suction Pressure Invalid - The reading of the suction pressure transmitter is not within the specified sensor range of 0 to 16bar (0 to 232psi). Possible causes are faulty wiring or a defective transmitter.

E81, ASB Leak Detected - The gas sensor has detected a leak. The ABS will communicate the leak to the ABC control board. Compressor and auxiliary heat will be deactivated, and blower will come on.

Aurora Control System

E82, ASB Sensor Problem - The gas sensor has lost communication with the ASB board or has an internal error.

E97, Invalid System Configuration - ABC has not been configured for sensor or refrigeration type.

Aurora Error Codes

NOTE: The system is operating normally, but a sensor or communication issue is preventing full features of the system. Since these can be deemed non-critical to system operation, such as internet access boards etc., they may simply cause errors/alerts that signal the user to the situation but may not effect normal operation.

E13, Non Critical AXB Sensor Error - Fault is recognized when a sensor faults that is not critical to heat pump operation. These sensors would include the performance, energy monitoring and refrigeration sensors.

E18, Error Non-Critical Communication Error - A non-critical communication error has occurred such as communication to the internet access board. Since this is not critical to unit operation, the heat pump will continue operating normally with this error displayed on the ABC board and the thermostat. The AID Tool should be used to view the configuration window and ascertain the status of all appropriate board communication. The Error displayed will be removed when the problem has been resolved.

Aurora SafeMode Codes

NOTE: The system is still operational during safemode. It is possible for some situations to progress from Derating to SafeMode to finally locking out due to a fault.

E72, SafeMode EEV - Suction Temperature Invalid - The reading of the suction temperature sensor is not within the specified sensor range of -60 to +200°C (-76 to +392°F). The EEV will be positioned at 50%. Possible causes are faulty wiring or a defective sensor.

E73, SafeMode EEV - Leaving Air Temperature (LAT) Invalid - The reading of the leaving air temperature sensor is not within the specified sensor range of -60 to +200°C (-76 to +392°F). Normal operation will continue with an Error 73 display on the thermostat to notify the user of the issue. Possible causes are faulty wiring or a defective sensor. The Error displayed will be removed when the problem has been resolved.

E74, SafeMode EEV - Maximum Operating Pressure (MOP)

- The reading of the suction pressure is above the recommended limit. If this condition persists more than 90 seconds, the Drive will revert to a Fault - Out of Envelope Code 35.

Aurora Alarm Codes

These alarms are planned to alert the homeowner and the service personnel but will NOT effect system operation and are for information only. These would be available on the thermostat, AID Tool and the internet access for remote monitoring capability.

E21, Loop Pressure Alarm - Fault is recognized when the loop pressure sensor is installed and the loop pressure falls below the setpoint.

E23 and E24, Home Automation 1 and 2 Inputs - The Home automation inputs are simple 24VAC inputs that will trigger an AID Tool and thermostat alert for the homeowner. These would require optional sensors and or equipment for connection to the AXB board. With two inputs, two different sensors can be selected. The selected text will then be displayed on the AID Tool and com thermostats. These events will NOT alter functionality or operation of the heat pump/accessories and is for homeowner/service notification only. With a closed dry contact signal, this input will cause an alarm E23 or E24 to indicate on the stat or flash on ABC. The AID Tool will allow configuration of these two inputs independently between the following selections:

- *No Action*
- *Home Automation Fault [no lockout, info only]* - Output from home automation system

Compressor & Thermistor Resistance

Compressor Resistance Table (77°F)

Terminals	024 YA25K1E	048 YA51K1E	060 YA57K1E
Run	0.828 - 0.952	0.363 - 0.417	0.317 - 0.359
Start	1.458 - 1.676	0.727 - 0.837	0.857 - 0.986

NOTE: Resistance listed are for single phase (208-230/60hz) compressors.

Thermistor Table

Thermistor Temperature (°F)	Resistance (Ohms)
78.8	9,230 - 10,007
77.5	9,460 - 10,032
76.5	9,690 - 10,580
75.5	9,930 - 10,840
33.5	30,490 - 32,080
32.5	31,370 - 33,010
31.5	32,270 - 33,690
30.5	33,190 - 34,940
1.5	79,110 - 83,750
0.5	81,860 - 86,460
0.0	82,960 - 87,860

Reference Calculations

Heating Calculations:	Cooling Calculations:
$LWT = EWT - \frac{HE}{GPM \times C^*}$	$LWT = EWT + \frac{HR}{GPM \times C^*}$
$HE = C^* \times GPM \times (EWT - LWT)$	$HR = C^* \times GPM \times (LWT - EWT)$

NOTE: * C = 500 for pure water, 485 for brine.

Legend

Abbreviations and Definitions

ELT = entering load fluid temperature to heat pump	kW = kilowatts
SWPD = source coax water pressure drop	EST = entering source fluid temperature to heat pump
LLT = leaving load fluid temperature from heat pump	HE = heat extracted in MBTUH
PSI = pressure drop in pounds per square inch	LST = leaving source fluid temperature from heat pump
LGPM = load flow in gallons per minute	HC = total heating capacity in MBTUH
FT HD = pressure drop in feet of head	COP = coefficient of performance, heating [HC/kW x 3.413]
LWPD = load coax water pressure drop	EER = energy efficiency ratio, cooling
LWT = leaving water temperature	TC = total cooling capacity in MBTUH
EWT = entering water temperature	HR = heat rejected in MBTUH
Brine = water with a freeze inhibiting solution	

Notes to Performance Data Tables

The following notes apply to all performance data tables:

- Three flow rates are shown for each unit. The lowest flow rate shown is used for geothermal open loop/well water systems with a minimum of 50°F EST. The middle flow rate shown is the minimum geothermal closed loop flow rate. The highest flow rate shown is optimum for geothermal closed loop systems and the suggested flow rate for boiler/tower applications.
- Entering water temperatures below 40°F assumes 15% antifreeze solution.
- Interpolation between ELT, EST, and GPM data is permissible.
- Operation in the gray areas is not recommended.

Preventative Maintenance

1. Keep all air out of the water lines. An open loop system should be checked to ensure that the well head is not allowing air to infiltrate the water line. Lines should always be airtight.
2. Keep the system under pressure at all times. In open loop systems, it is recommended that a water control valve be placed in the discharge line to prevent loss of pressure during off cycles. Closed loop systems must have a positive static pressure.

NOTES: If the installation is performed in an area with a known high mineral content in the water, it is best to establish a periodic maintenance schedule to check the water-to-refrigerant heat exchanger on a regular basis. Should periodic cleaning be necessary, use standard cleaning procedures which are compatible with either the cupronickel or copper water lines. Generally, the more water flowing through the unit, the less chance there is for scaling. Low GPM flow rates produce higher temperatures through the coil. To avoid excessive pressure drop and the possibility of copper erosion, do not exceed GPM flow rate as shown on the specification sheets for each unit.

Cleaning Procedure

1. Close the inlet and outlet water valves to isolate the heat pump from the well system, water heater or loop pumps.
2. Disconnect piping and remove solenoid valve, pumps, etc, from the inlet and outlet connections on the heat pump.
3. Connect plastic hoses from the circulating pump* to the outlet of the water-to-refrigerant heat exchanger to be de-limed (refer to the Cleaning Connections illustration).

4. Connect a plastic hose from the circulating pump inlet to the bottom of a plastic five (5) gallon pail (refer to the Cleaning Connections illustration).
5. Connect a plastic hose from the inlet line of the water-to-refrigerant heat exchanger to the plastic pail. Secure tightly to ensure that circulating solution does not spill (refer to the Cleaning Connections illustration).
6. Partially fill the plastic pail with clear water (about two-thirds full) and prime the circulating pump. Circulate until lines are full.
7. Start the circulating pump and slowly add a commercial scale remover** to the water as recommended by the scale remover manufacturer's directions.
8. Be sure the pump circulation is opposite to the normal water flow through the water-to-refrigerant heat exchanger.
9. Maintain re-circulation until all scale and other material has been dissolved and flushed from the heat exchanger.
10. Upon completion of the procedure. Safely dispose of the solution.
11. Rinse the pump and plastic pail. Refill with clear water.
12. Start the pump circulation and flush the system until all acid residue has been removed from the system. Refill the plastic pail until only clear water is circulated.
13. Turn off the circulating pump and disconnect all hoses and fittings.
14. Replace solenoid valves, pumps, hoses and other devices in their original locations. On closed loop systems, be sure to purge between the flow center and unit to avoid getting air into the loop.
15. Put the heat pump back into operation. Check for proper operating temperature.

Cleaning Connections

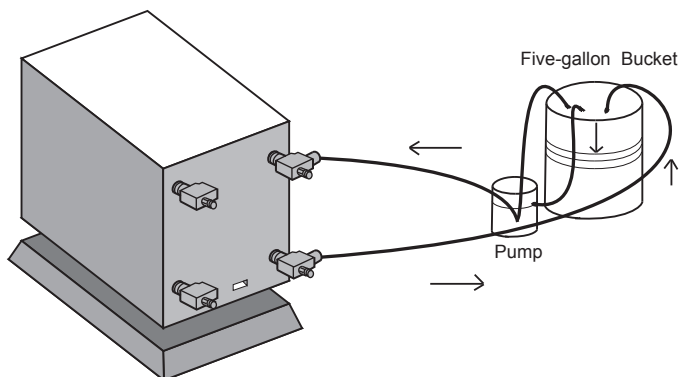

WARNING: This process involves a caustic solution and may be harmful to people and animals. Wear protective equipment (glasses, rubber gloves, apron, etc.)

NOTES: *Virginia Chemical Co. makes a Pump model H460.

* W.W. Granger Co. sells a Pump #2P-017 made by Little Giant.

**Virginia Chemical Co. makes a liquid ice machine cleaner which should be used on water-to-refrigerant heat exchangers serving a domestic hot water system. Calci-Solve by NYCO is available for use on other heat exchangers

Troubleshooting

Aurora Control System

NOTE: Refer to the Aurora Base Control Application and Troubleshooting Guide and the Instruction Guide: Aurora Interface and Diagnostics (AID) Tool for additional information.

To check the unit control board for proper operation:

1. Disconnect thermostat wires at the control board.
2. Jumper the desired test input (Y1, Y2, W, O or G) to the R terminal to simulate a thermostat signal.
3. If control functions properly:
 - Check for thermostat and field control wiring (use the diagnostic inputs mode).
4. If control responds improperly:
 - Ensure that component being controlled is functioning (compressor, blower, reversing valve, etc.).
 - Ensure that wiring from control to the component is correct.
 - Refer to the Aurora Base Control Application and Troubleshooting Guide and the Instruction Guide: Aurora Interface and Diagnostics (AID) Tool for additional information.

Refrigerant Systems

To maintain sealed circuit integrity, do not install service gauges unless unit operation appears abnormal. Compare the change in temperature on the air side as well as the water side to the Unit Operating Parameters tables. If the unit's performance is not within the ranges listed, and the airflow and water flow are known to be correct, gauges should then be installed and superheat and subcooling numbers calculated. If superheat and subcooling are outside recommended ranges, an adjustment to the refrigerant charge may be necessary.

NOTE: Refrigerant tests must be made with hot water generator turned "OFF". Verify that air and water flow rates are at proper levels before servicing the refrigerant circuit.

Aurora Interface Diagnostic (AID) Tool

Aurora Input-Output Diagnostics



Troubleshooting the Aurora logic board can be accomplished using nothing more than a couple of jumper wires and a volt meter. The process can be simplified with the use of the Aurora Interface Diagnostic Tool (AID Tool). The AID Tool allows the user to see lockout and fault history information, thermostat inputs, sensor inputs, system outputs, timer, etc.

Aurora ABC Checkout

Before replacing the Aurora ABC control board the proper troubleshooting steps must be taken to ensure that the board is the root cause. On the following pages are several flow charts that will assist in checking the control board. If it is found that the control board is faulty, contact technical services for a replacement part.

LED Displays

Slow Flash = 1 second on and 1 second off

Fast Flash = 100 ms on and 100 ms off

Flash Code = 100 ms on and 400 ms off with a 2 second pause between packages

SW1 Operation

Holding SW1	Description of Operation	LED
2 to 5 sec	Enter Test Mode	Green LED Slow Flash
5 to 10 sec	Enter ECM Configure Mode	Yellow LED Off
50 to 60 sec	Reset Configure Mode (default)	Yellow LED Off
> 60 sec	SW1 Operation Cancel	Yellow LED Back to Normal

"SW1 operation cancel," holding SW1 for longer than 60 seconds operation will be cancelled. Yellow LED will go back to normal operation.

Fault Retries Before Lockout

Type of Fault	Total Tries Before Lockout
High Pressure	3 Retries
Low Pressure	3 Retries
Freeze Detection 1 - (Coax)	3 Retries
Freeze Detection 2 - (Air coil)	3 Retries
Condensate Overflow	3 Retries
Over/Under Voltage Shutdown	No Lockout
Compressor Monitor	No Retry
Freeze Detection Sensor Error (Sensor is out of range)	No Retry

Preliminary Checkout Procedure

Troubleshooting liquid source heat pumps with Aurora controls is an easy and straight forward process. Most service problems are related to water flow (insufficient or too cold). Also, most service problems can be fixed without connecting refrigerant manifold gauges.

The first item to check is system performance which can be done in six steps. Before beginning make sure the hot water generator pump is disconnected.

STEP 1: Check and/or set source water flow. Refer to the install manual for the specific piece of equipment's correct water flow setting.

STEP 2: Check the temperature difference through the coaxial heat exchanger and compare to the Operating Parameters table in the equipment install manual.

STEP 3: Check the air temperature rise/drop and compare to the Operating Parameters table in the equipment's installation manual.

STEP 4: If the first three steps check out, perform a heat of extraction/rejection test as described in the Water Side Analysis: Heat of Extraction/Rejection section to confirm proper operation.

STEP 5: If any or all of the above steps do not check out, be sure that the air coil and filter are clean.

STEP 6: Check superheat and subcooling by placing refrigeration gauges on the unit. Compare superheat and subcooling values with the charts in the equipment installation manual.

If the above six steps do check out, it would be safe to assume that the unit is performing well and the problem must lie elsewhere, i.e. excessive heat loss/gain in the structure or duct system, (undersized duct and/or registers, etc.)

If you suspect a specific problem, refer to the Table of Contents and select the reference that most closely matches the situation encountered. If problems persist after completing the preliminary checkout procedure, refer to the Troubleshooting Checklist. Select the problem which is closest to the situation you have encountered.

Troubleshooting Checklist

Equipment will not start or operate

- Follow the troubleshooting flow charts to find root cause.

High pressure lockout in the heating mode

- Check for air flow interruption from one or more of the following: inoperative blower, dirty filters or air coil, blocked return air grille, closed or blocked supply registers, restricted supply or return duct, zone dampers, etc. If airflow is suspected as being a problem, make a quick check using the following example: Velocity in a supply duct should not exceed 1000 fpm and 700 fpm in return ducts. For this example we will use an model 038 which has a maximum rating of 1500 cfm at 0.50 static (Refer to the blower performance tables in the install manual for your particular piece of equipment). Using the formula: Area in square feet equals quantity in cfm divided by velocity in fpm ($A=cfm/fpm$), 1.57 sq. ft. is needed for the supply duct and 2.14 sq. ft. is needed for the return duct. Refer to the troubleshooting flow charts if a problem with the blower motor or logic board is suspected.
- Check for blocked or seized expansion device.
- Make sure the discharge pressure is within the operating range shown in this product manual.
- The unit may be overcharged; check superheat and sub cooling. If this problem is verified, recharge using approved methods.

High pressure lockout in the cooling mode

- Water flow may be restricted or inadequate. Verify in accordance with the pressure drop tables shown in product install manual. Also, look for the following: solenoid valve may not be opening on well water units, pump(s) may be inoperative in the flow center, debris may be blocking coil (back flush using at least 20 PSI), or air may be in the loop (flush loop).
- Water to refrigerant heat exchanger may be fouled with debris. If so, back flush with at least 20 psi of water pressure.
- If mineral accumulation is evident, clean the heat exchanger with acid.
- Entering air temperature may be too high. Equipment is designed for a maximum of 85°F DB and 71°F WB.
- Check for a seized or blocked expansion device.
- The unit may be overcharged; check superheat and sub cooling. If this problem is verified, recharge using approved methods.

Low pressure lockout in heating mode

- If equipment is installed in a low temperature area (below 50°F), install a crankcase heater, then protect the unit from the elements.
- Water flow may be restricted or inadequate. Verify in accordance with the pressure drop tables shown in this product manual. Also, look for the following: solenoid valve may not be opening on well water units, pump(s) may be inoperative in the flow center, debris may be blocking coil (back flush using at least 20 PSI), or air may be in the loop (flush loop).
- Check for a seized or blocked expansion device.

- Return air temperature may be below 50°F. Block off air coil temporarily to improve flow of refrigerant through the system. Air below 50°F cannot be tolerated on a continuing basis. Correct the problem.
- Refrigerant may be low. Check for leaks, reclaim refrigerant, repair if necessary, recharge using approved methods.

Low pressure lockout in the cooling mode

- Check for inadequate air flow. Follow the same procedure as shown for a high pressure lockout in the heating mode.
- Check for a seized or blocked expansion device.
- Refrigerant charge may be low.

Water flow lockout in either the heating or cooling mode

- Water flow may be restricted or inadequate. Verify in accordance with the pressure drop tables shown in product install manual. Also, look for the following: solenoid valve may not be opening on well water units, pump(s) may be inoperative in the flow center, debris may be blocking coil (back flush using at least 20 PSI), or air may be in the loop (flush loop).
- Disconnect freeze sensor from control and measure the resistance. Cross reference with the Thermistor Data table.

Reversing valve does not operate

- Disconnect solenoid and check for continuity across coil. Replace coil if continuity is not found.
- If stuck reversing valve is suspected, restrict airflow in heating mode (to build pressure), then switch immediately to the cooling mode.

Control Board Troubleshooting Steps

1) General Check

- If any new device was installed, or any wiring was changed, check the connections to ensure the wiring is correct, and all the wires are in good condition.
- Verify all the plugs are securely connected and in good condition.
- Check the DIP switch (SW2) positions are correct.
- Measure 24 VAC between R and C. (The actual reading may be from 18 to 30 VAC). Check the incoming power and the power transformer if the R and C voltage reading is not correct.

2) No LEDs are On

- Check 24 VAC on board.
- Check the 3 amp fuse. Replace the fuse if needed.
- Verify transformer circuit breaker has not tripped if no low voltage is present.
- Disconnect the thermostat connection P1.
- Replace the Aurora base control board.

3) Red LED Flash Code

Input Fault (Code 1) – Indicates that both O and W input signals are present. Disconnect the thermostat connector from the ABC board and then cycle power to the board. If the fault does not reappear, then the problem is between the thermostat and the thermostat connector. Otherwise, replace the ABC board.

High Pressure Fault (Code 2) – Indicates the system pressure has exceeded 600 psi (R-454B) which may have been caused by low water flow in cooling, (check coaxial heat exchanger for mineral build-up) or low air flow in heating (check filters and coil for dirt build-up). Measure P4-9 and C is 24 VAC. If not, replace ABC. Check the heat pump refrigeration system. Cycle the power to reset the system. Measure P4-10 and C is 24 VAC. If not, replace the high pressure sensor.

Low Pressure Fault (Code 3) – Indicates low pressure switch has opened which may indicate a loss of system charge, system restriction, or frozen heat exchanger. Measure P4-7 and C is 24 VAC. If not, replace ABC. Check the heat pump refrigeration system. Cycle the power to reset the system. Measure P4-8 and C is 24 VAC. If not, replace the low pressure sensor. Refrigerant may be low. Check for leaks, reclaim refrigerant, repair if necessary, pump down and recharge the system to the quantity of refrigerant shown on the unit nameplate.

Freeze Detection 1 Fault (Code 5) – Indicates low or no water flow; low system charge; or faulty expansion device in heating mode. Make sure the DIP switch FP1 (SW2-1) selection matches the application. Measure the temperature on the refrigerant line next to the freeze detection thermistor. Disconnect the connector P4. Measure the resistance reading between P4-3, P4-4. Refer to the Thermistor Data table, find the corresponding temperature data. Compare the data with the temperature measurement from the refrigerant line. The temperature should be within +/- 2° F. If not, replace the thermistor.

Other items to check when troubleshooting a water flow lockout are superheat, water flow through the coaxial heat exchanger and antifreeze composition. High superheat in heating will lower the refrigerant line temperature where the freeze detection thermistor is located. In this case, check the expansion device. Closed loop systems are rated at 3 gpm/ton. If a closed loop system is running at less than 3 gpm/ton, the temperature difference between the refrigerant line and the actual leaving water temperature will be greater and could lead to possible water flow lockouts.

Condensate Fault (Code 7) – Indicates condensate water in the drain pan fills up and touches the spade terminal. Make sure the drain line pitches away from the unit. Install a vertical vent on horizontal drain lines over six feet long. Clean and be sure outlet and drain line from the condensate pan is clear. Jumper between R, Y2 and O to start 2nd stage cooling. Observe the water level in the drain pan. If the unit is locking out on condensate and the drain pan is dry, remove the condensate wire from the drain pan and tape it out of the way. Be careful to not ground the wire out because that will cause the unit to lockout on drain overflow. If the unit is still locking out, check the brown wire all the way back to the ABC for a short to ground. Remember that the condensate sensor is just a wire looking for a ground. If it touches any metal in the cabinet, the unit will see that as a drain fault. If removing the wire from the drain pan stopped the false drain lockouts, put the condensate sensor back in place in the drain pan. Pay close attention to how far the spade terminal sits down in the drain pan. If the terminal is pushed all the way down so that it is touching the bottom of the drain pan, this will cause a drain lockout if there is any trace of water. If the spade terminal fits loosely in the drain pan, spread the terminal open to make it fit snugly in the drain pan.

Over/Under Voltage Shutdown Fault (Code 8) – Indicates the control voltage is or had been outside the range of 18 to 30 VAC for more than 15 minutes. Using a voltage meter, check the incoming power line voltage is within + or – 25%. If not, there is a power line issue. Check the secondary of the control transformer with a voltage meter. The voltage should be 18 to 30 VAC. If not, replace the control transformer.

Freeze Detection FP1 Sensor Fault (Code 11) – Indicates the freeze detection sensor is out of range. Disconnect the connector P4. Measure the resistance reading between P4-3, P4-4. Refer to the Thermistor Data table, find the corresponding temperature data. Compare the data with the temperature measurement from the refrigerant line. The temperature should be within +/- 2°F. If not, replace the thermistor.

Control Board Troubleshooting Steps cont.

Compressor First Stage Will Not Start – Measure the voltage output between P5-4 and P5-5, P5-7 and P5-8. The reading should be 24 VAC. If 24 VAC is not present check transformer output, thermostat wiring, current fault status, etc.

Compressor Second Stage Will Not Start – Measure the voltage output between P5-6 and P5-8. The reading should be 24 VAC. If 24 VAC is not present, check DIP switch settings, thermostat operation, and thermostat wiring.

No Alarm Output – Measure the voltage output between P2-4 and C. The reading should be 24 VAC or a pulsed 24 VAC dependent on the selection of SW2-7. If SW2-8 is set for reheat, the alarm output will be used to control the hot gas reheat valve and will not show lockout information.

Accessory Relay Does Not Operate – Measure the continuity between P2-2 and P2-3. It should read closed when relay is engaged. If this is not correct, check SW2-4 and SW2-5 settings.

No Lockout Output – Measure the voltage output between P1-1 and C. The reading should be 24 VDC or a pulsed 24 VDC dependent on the selection of SW2-7. If voltage is not present, make sure the unit is in lockout and not fault retry.

Auxiliary Heater Does Not Function – Measure the voltage output between P3-1, P3-2, and P3-3, P3-4. The output should be 24 VDC. If voltage is not present, check thermostat operation and wiring.

Loop Pump Does Not Start – The loop pump is controlled by the AXB board. Check to make sure the control board is powered by taking a voltage reading across R and C to check for 24VAC. If 24VAC is not present check the wiring connections, 24VAC is supplied to the AXB through the harness connected to P9. Next check to make sure the ABC is attempting to run the compressor, the loop pump will only run when the ABC is commanding CC on, the pump slave input is active, or the AXB has lost communication with the ABC. Please refer to troubleshooting flow charts for additional checks on the loop pump.

5) Operation Modes

Enter First Stage Heating – Remove P1. Place a jumper between R and Y1.

Enter Second Stage Heating – Remove P1. Place a jumper between R, Y1 and Y2. This is for SW2-6 set to “OFF” position.

Enter Third Stage Heating – Remove P1. Place a jumper between R, Y1, Y2 and W.

Enter First Stage Cooling – Remove P1. Place a jumper between R, O and Y1.

Enter Second Stage Cooling – Remove P1. Place a jumper between R, O, Y1 and Y2.

Enter Emergency Heating – Remove P1. Place a jumper between R and W.

Enter Blower Only Mode – Remove P1. Place a jumper between R and G.

Enter Reheat Mode – Remove P1. Place a jumper between R and DH. (SW2-8 must be off)

These notes are for SW2-3 set to “ON” position.

Control Board Troubleshooting Flow Charts

Use the following flow charts to aid in troubleshooting the control board.

Compressor Will Not Start Without AID Tool

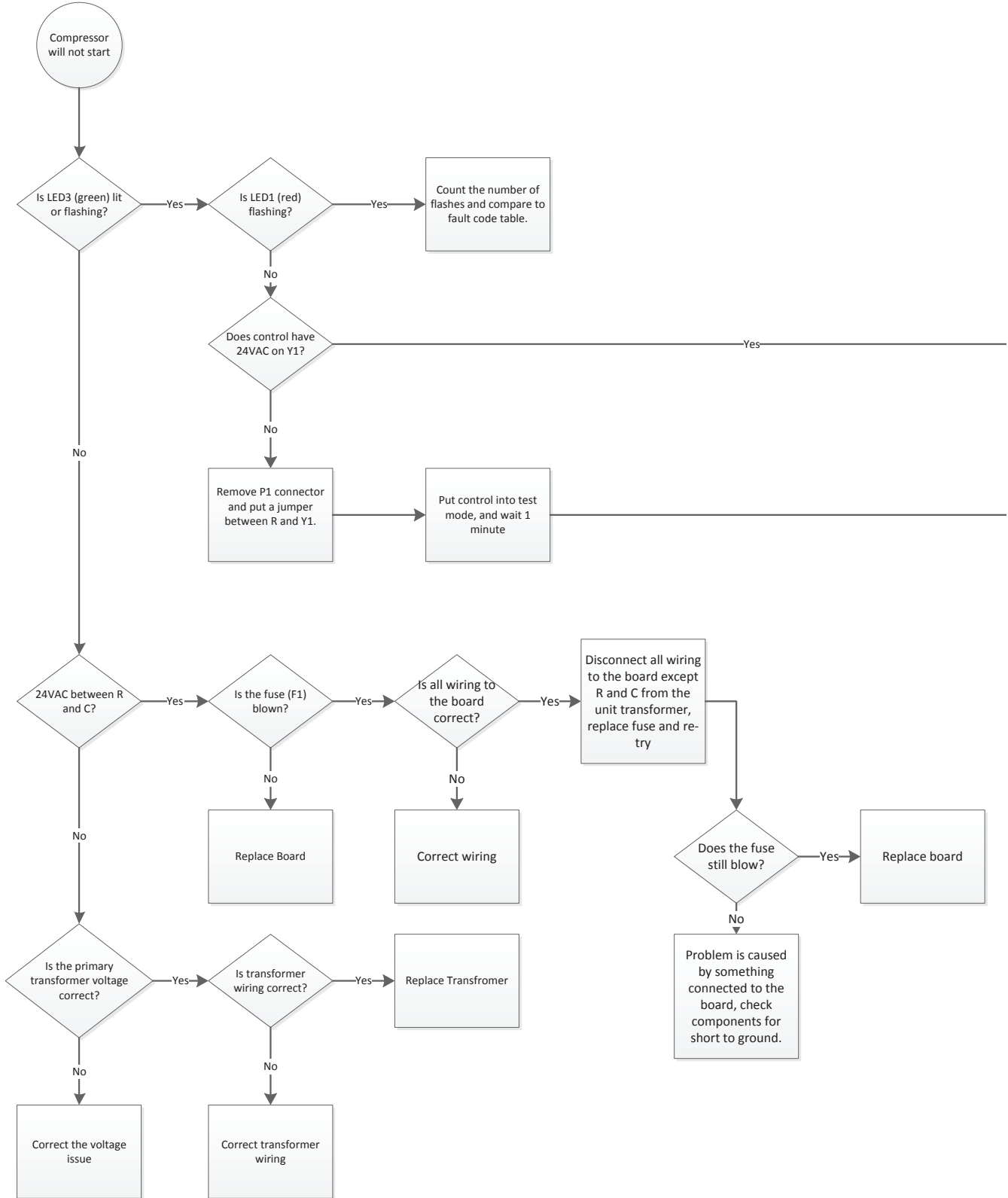

Control Board Troubleshooting Flow Charts cont.

Notes:

1. When measuring 24VAC actual value may be between 18 and 30VAC.

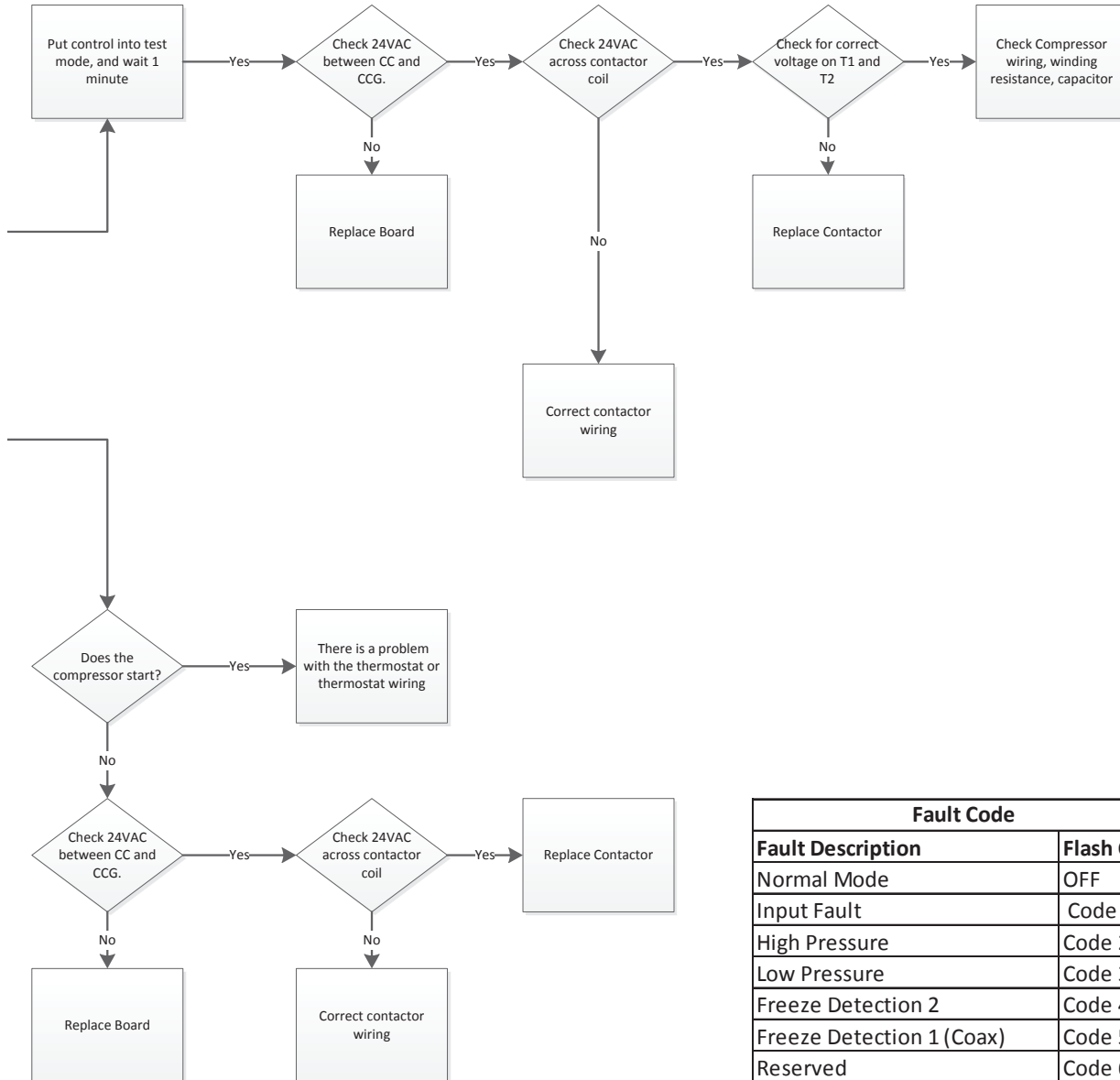

Fault Code	
Fault Description	Flash Code
Normal Mode	OFF
Input Fault	Code 1
High Pressure	Code 2
Low Pressure	Code 3
Freeze Detection 2	Code 4
Freeze Detection 1 (Coax)	Code 5
Reserved	Code 6
Condensate	Code 7
Over/Under Voltage	Code 8
Not Used	Code 9
Freeze Detection Sensor Error	Code 11

NOTE: Refer to the Control Board Troubleshooting Steps for fault descriptions.

Control Board Troubleshooting Flow Charts cont.

Compressor Will Not Start With AID Tool

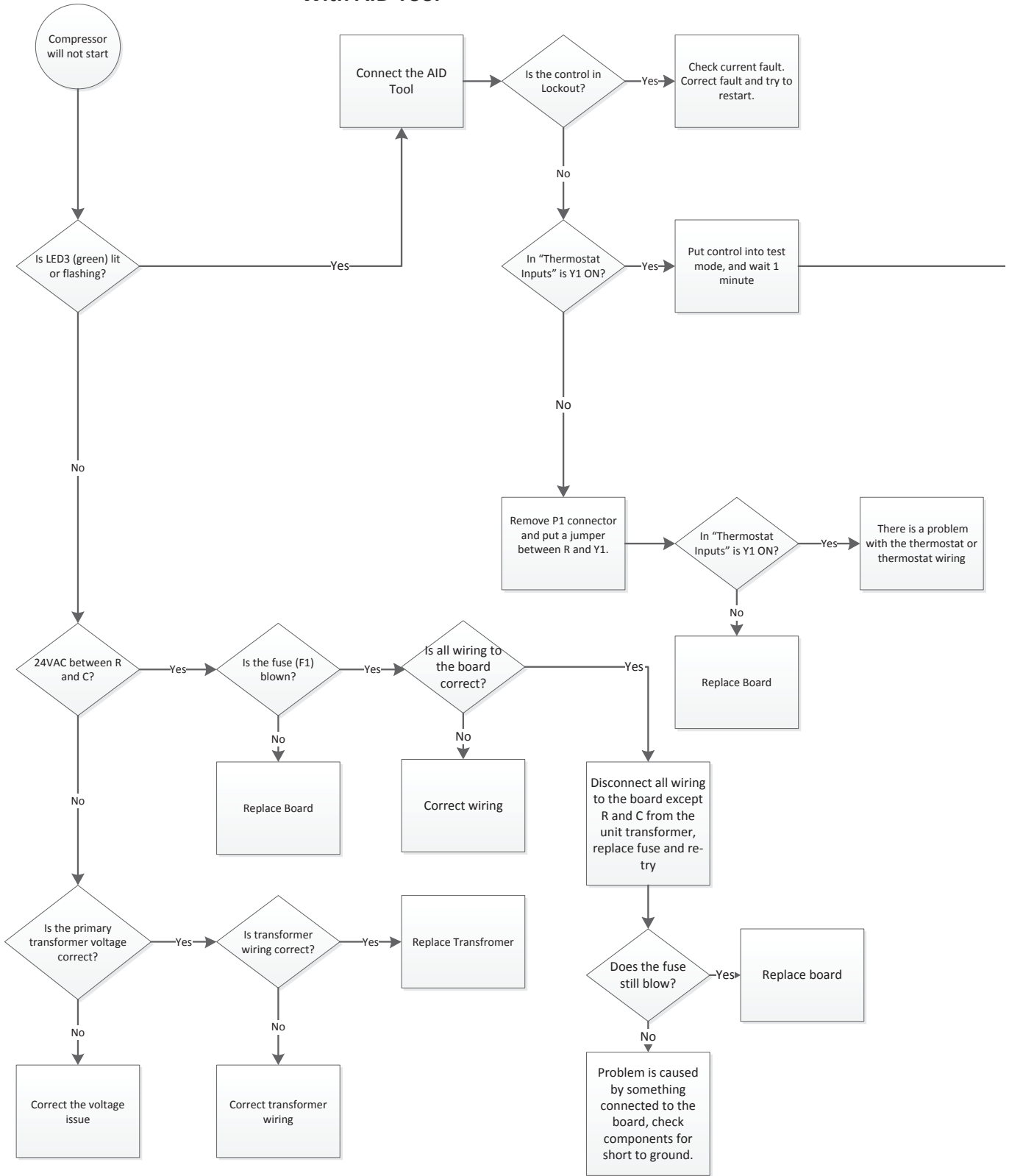

Control Board Troubleshooting Flow Charts cont.

Notes:

1. When measuring 24VAC actual value may be between 18 and 30VAC.

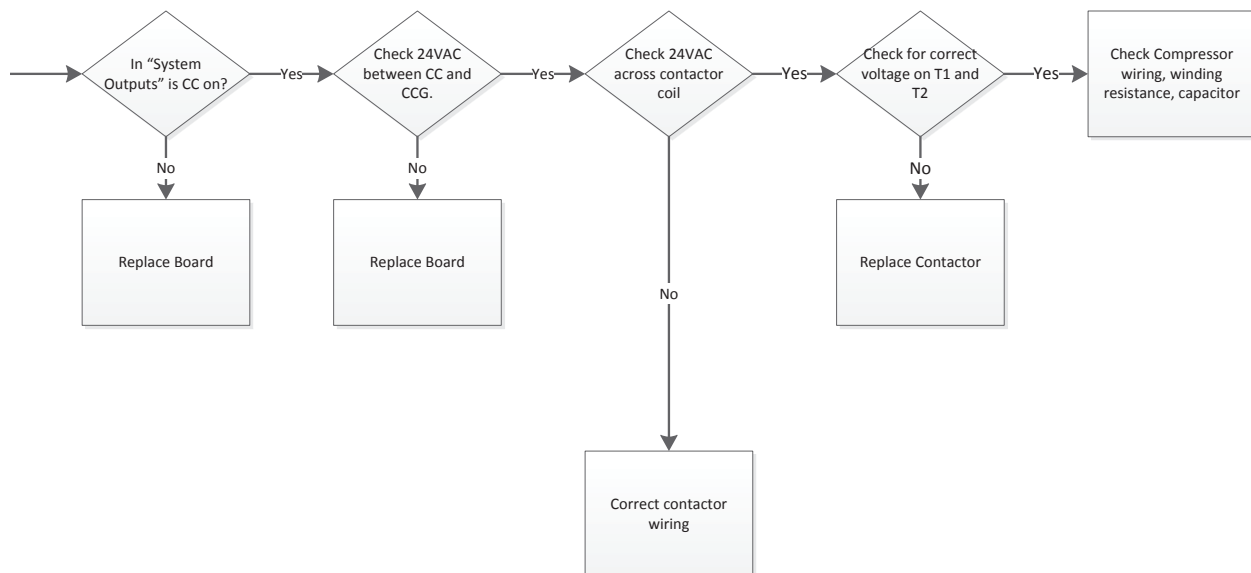

Control Board Troubleshooting Flow Charts cont.

Loop Pump Will Not Start Variable Speed Pump

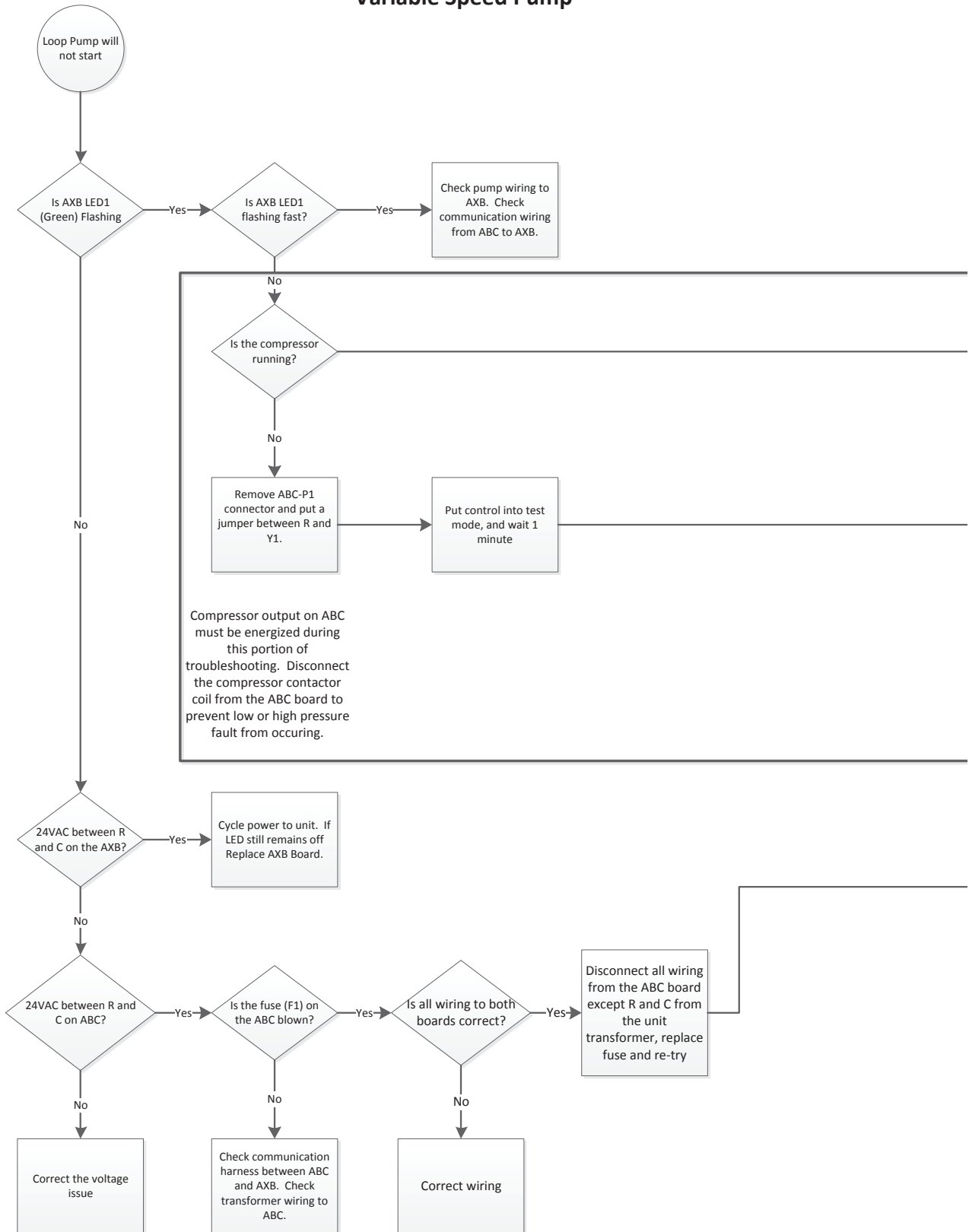

Control Board Troubleshooting Flow Charts cont.

Notes:

1. When measuring 24VAC actual value may be between 18 and 30VAC.
2. When measuring 240VAC actual value may be between 190 and 250 VAC.

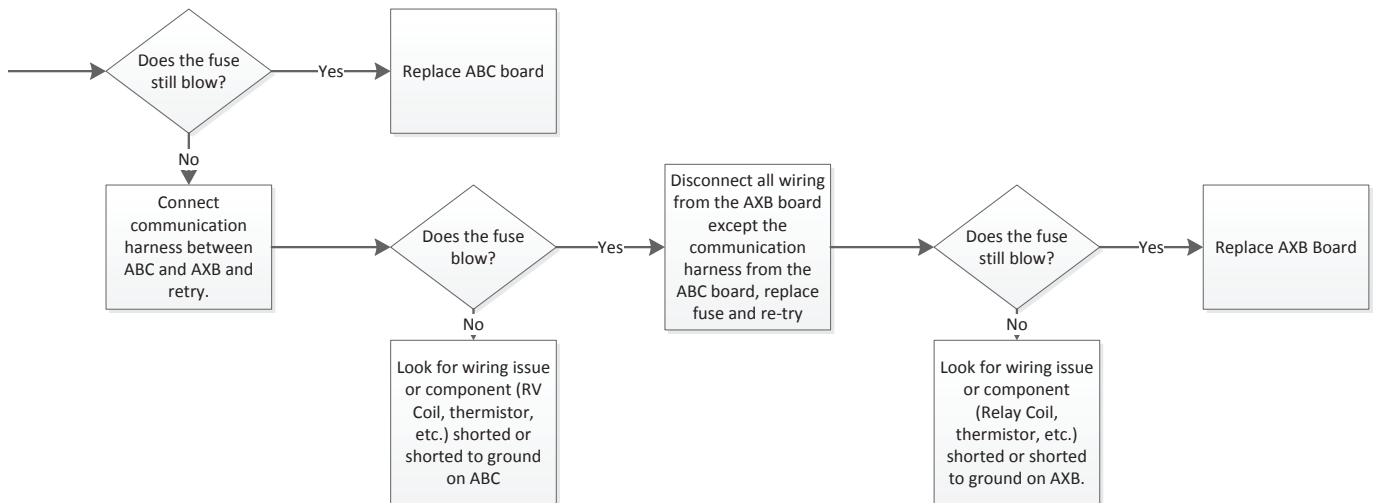
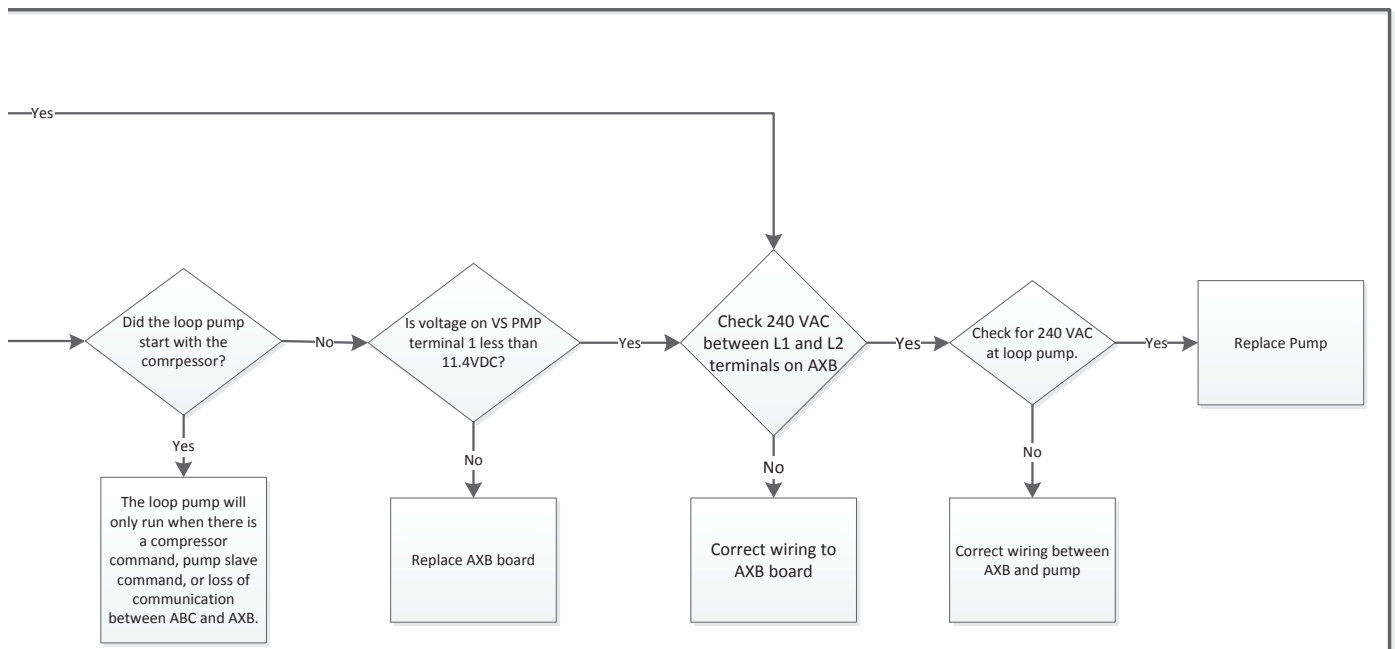

Control Board Troubleshooting Flow Charts cont.

Loop Pump Will Not Start Non Variable Speed Pump

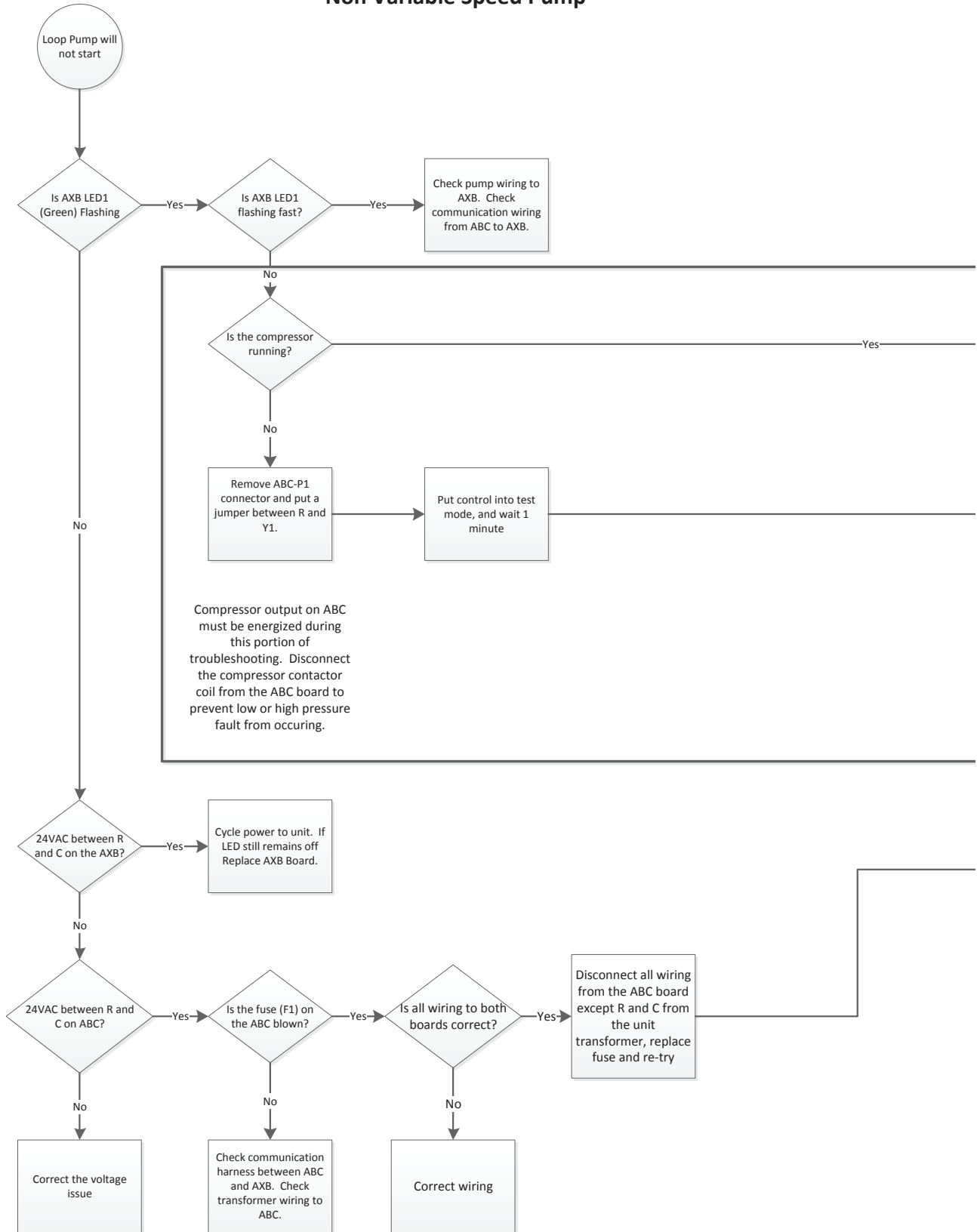

Control Board Troubleshooting Flow Charts cont.

Notes:

1. When measuring 24VAC actual value may be between 18 and 30VAC.
2. When measuring 240VAC actual value may be between 190 and 250 VAC.

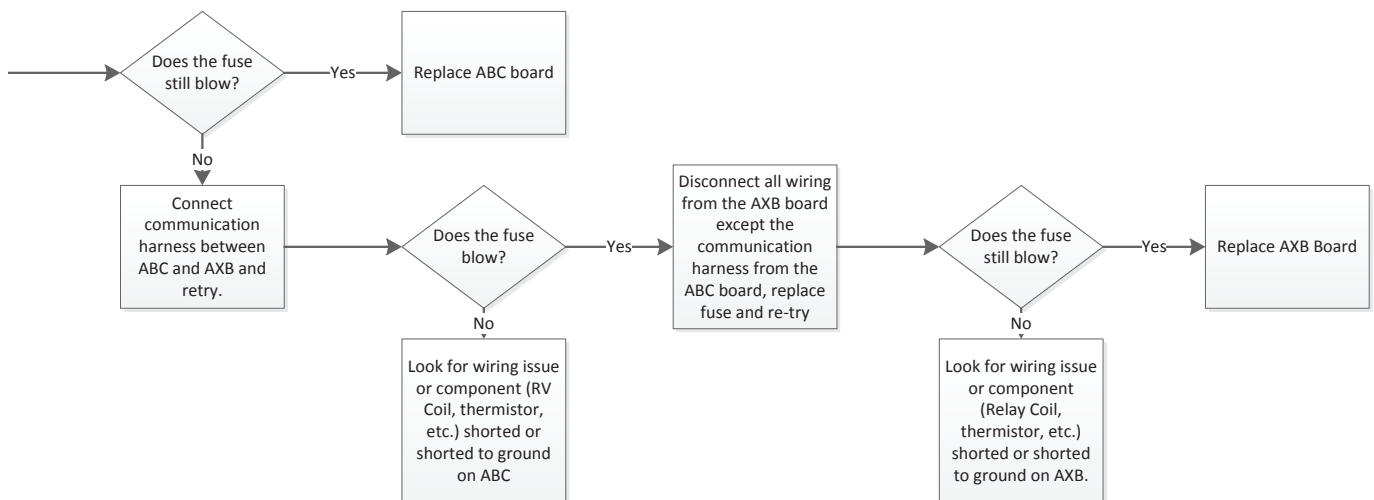
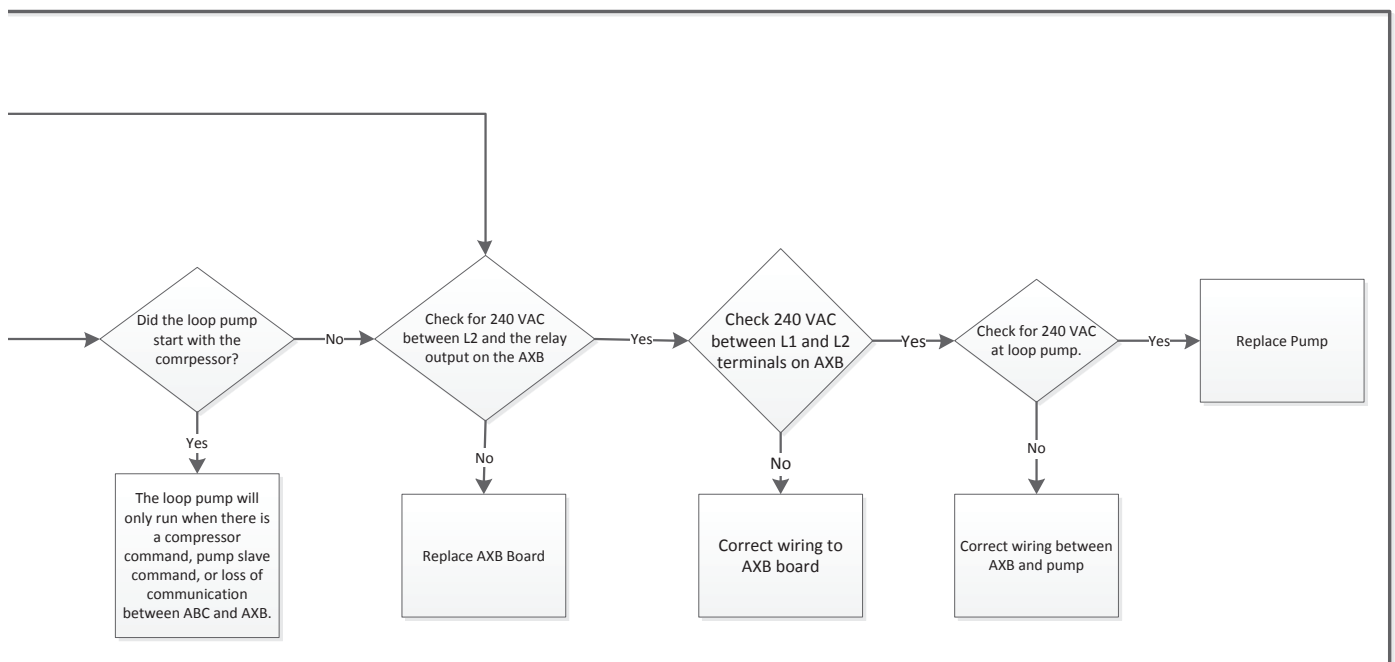

Communicating Thermostat Troubleshooting Guide

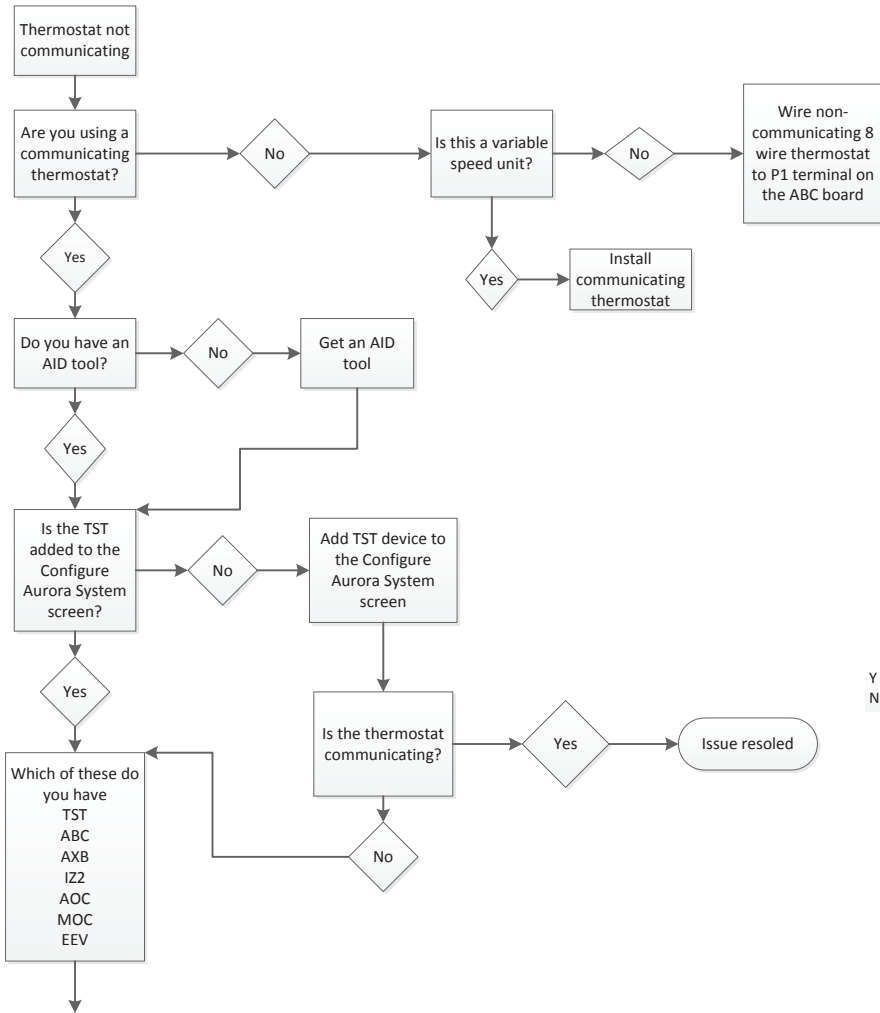

Configure Aurora System Screen

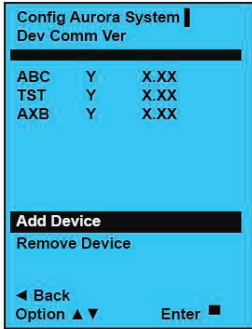

Single and Dual Capacity unit

Y – Active Communication
 N – Device has been found, but communication has failed.

Continue to Next Page

Communicating Thermostat Troubleshooting Guide cont.

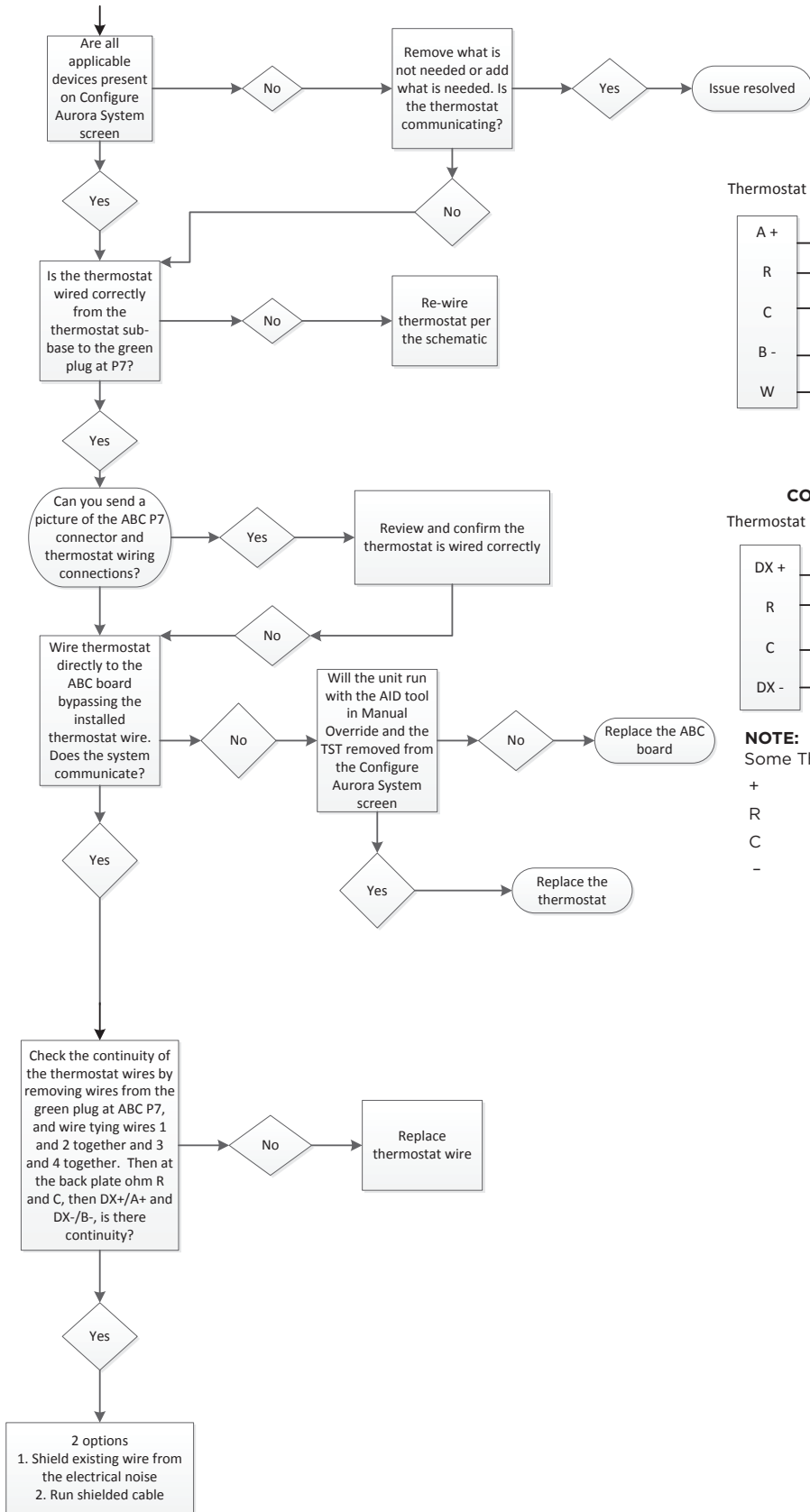

TPCM32U03A*/TPCM32U04A*

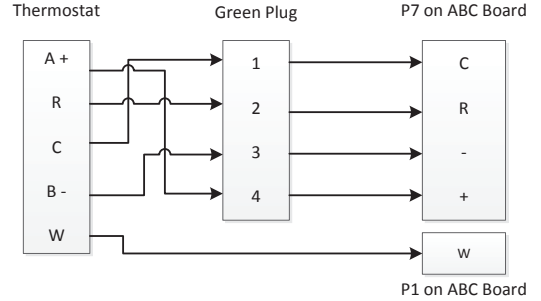

TPCC SERIES
COLOR TOUCHSCREEN THERMOSTAT

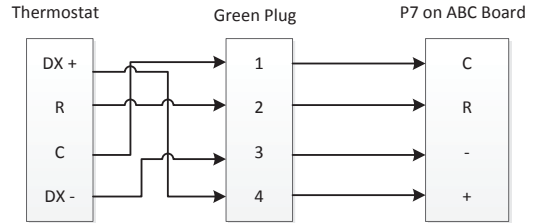

NOTE:
Some Thermostats will be:

- +
- R
- C
-

Control Board Signals

To Check for 24VAC between R and C

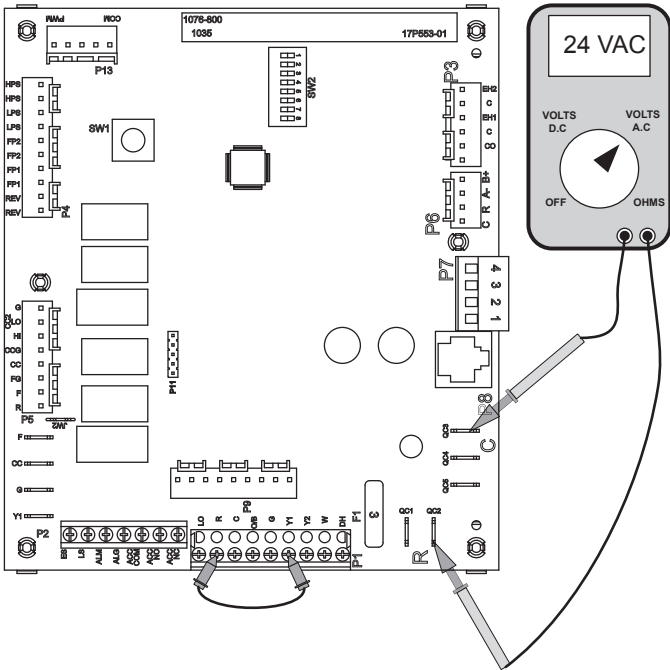

With power applied to the unit connect your Volt meter leads to “R” and “C” on the control board where the yellow and black/white transformer wires connect. The reading should be between 18VAC and 30VAC.

To Check for 24VAC to Compressor Contactor

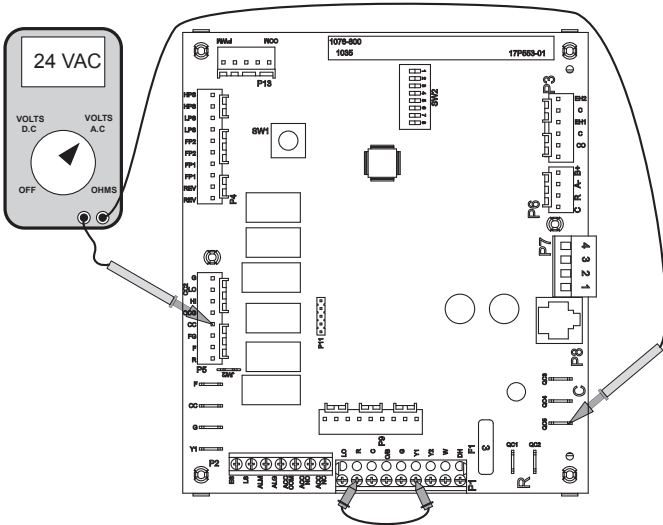

With the AID Tool go to the “Thermostat Inputs” Menu under “Diagnostics” and over-ride the “Y1” input to ON. If an AID Tool is not available remove the P1 connector to disconnect the thermostat from the board and place a jumper wire between “R” and “Y1” as shown. Apply power and put the board into test mode by holding SW1 for 2-5 seconds, the green LED will begin a slow flash. Connect your Volt meter leads to “CC” and “C”. After 1 minute the reading should be between 18 and 30VAC. If you have

a signal and the contactor is not pulled in, check voltage across the contactor coil. If you have voltage across the contractor coil, replace the contactor. If there is no voltage across the contactor coil, verify all wiring between the board and contactor. If you have no voltage between CC and C and the fault LED is not flashing, then replace the board.

To Check Operation of the Reversing Valve Output

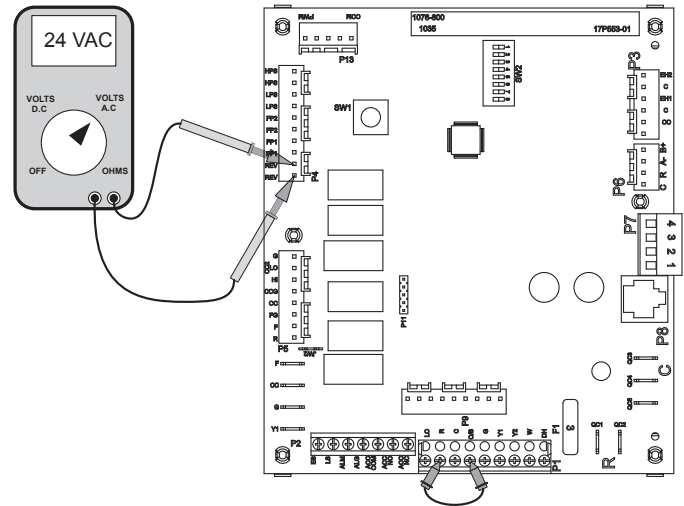

Make sure that SW2-3 is set to “ON”. With the AID Tool go to the “Thermostat Inputs” Menu under “Diagnostics” and over-ride the “O” input to ON. If an AID Tool is not available remove the P1 connector to disconnect the thermostat from the board and place a jumper wire between “R” and “O” as shown. Apply power and put the board into test mode by holding SW1 for 2-5 seconds, the green LED will begin a slow flash. Connect your Volt meter leads to the two “REV” pins on P4. The reading should be between 18 and 30VAC. If you have voltage and the reversing valve is not shifting, check voltage across the coil. If you have voltage across the reversing valve coil, but the valve does not shift the reversing valve coil may be bad. If there is no voltage across the coil, verify all wiring between the board and reversing valve. If no voltage is present on the two REV terminals then replace the board.

Control Board Signals cont.

To Check the Electric Heat Outputs

With the AID Tool go to the “Thermostat Inputs” Menu under “Diagnostics” and over-ride the “W” input to ON. If an AID Tool is not available remove the P1 connector to disconnect the thermostat from the board and place a jumper between “R” and “W” as shown. Put the board into test mode by holding SW1 for 2-5 seconds. The blower will come on and run in high speed. 10 seconds later electric heat output 1 (EH1) will be enabled followed by electric heat output 2 (EH2) in 7.5 seconds. Check EH1 by measuring DC volts between “C” and “EH1” and check EH2 by measuring DC volts between “C” and “EH2”.

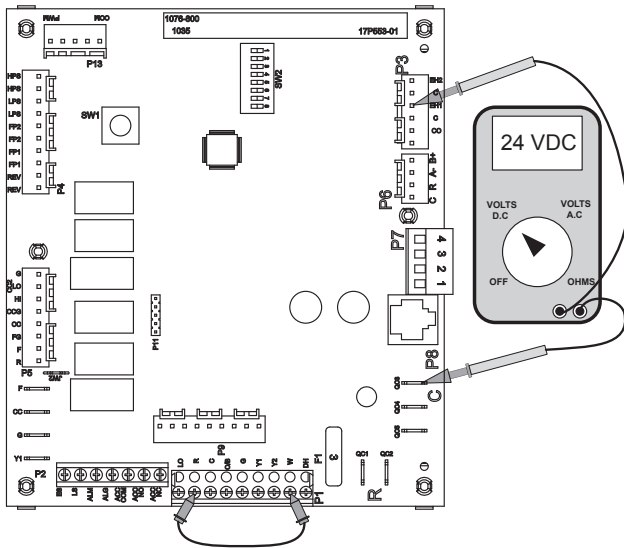

Jumping the Control Board

Stage 1 Heating

With the AID Tool go to the “Thermostat Inputs” Menu under “Diagnostics” and over-ride the “Y1” input to ON. If an AID Tool is not available remove the P1 connector to disconnect the thermostat from the board. Place a jumper between the “R” and “Y1” terminals as shown.

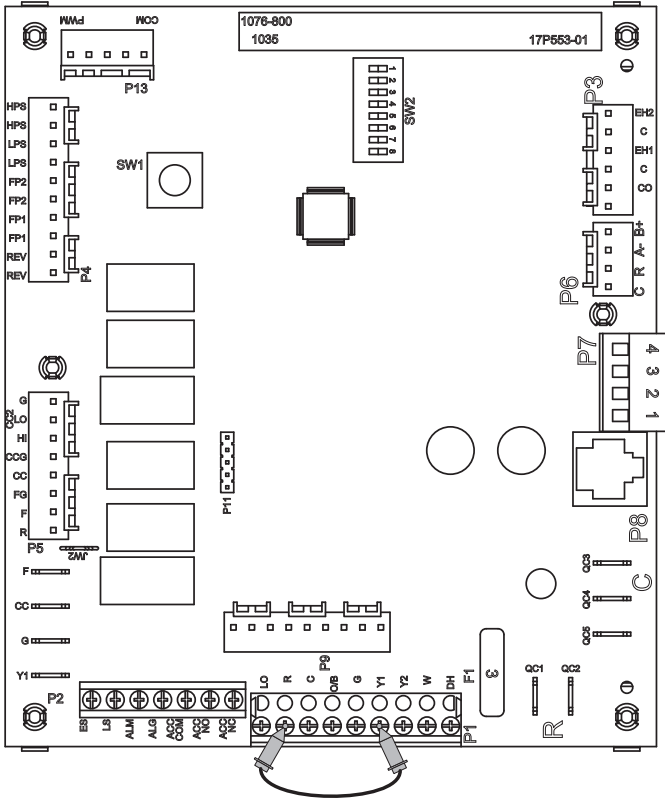

Stage 2 Heating (Dual Capacity Units Only)

With the AID Tool go to the “Thermostat Inputs” Menu under “Diagnostics” and over-ride the “Y1” and “Y2” inputs to ON. If an AID Tool is not available remove the P1 connector to disconnect the thermostat from the board. Place a jumper between the R, Y1, and Y2 terminals as shown.

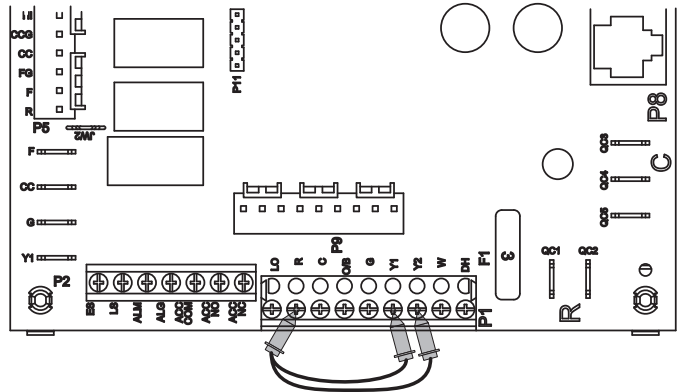

Jumping the Control Board cont.

Stage 1 Cooling

With the AID Tool go to the “Thermostat Inputs” Menu under “Diagnostics” and over-ride the “Y1” and “O” inputs to ON. If an AID Tool is not available remove the P1 connector to disconnect the thermostat from the board. Place a jumper between the R, O, and Y1 terminals as shown.

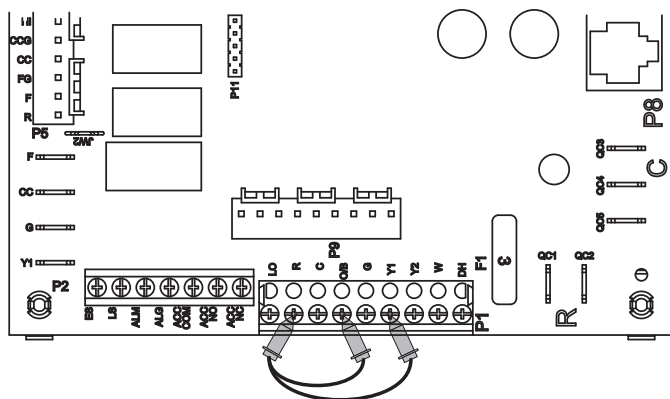

Stage 2 Cooling (Dual Capacity Units Only)

With the AID Tool go to the “Thermostat Inputs” Menu under “Diagnostics” and over-ride the “Y1”, “Y2”, and “O” inputs to ON. If an AID Tool is not available remove the P1 connector to disconnect the thermostat from the board. Place a jumper between the R, O, Y1, and Y2 terminals as shown.

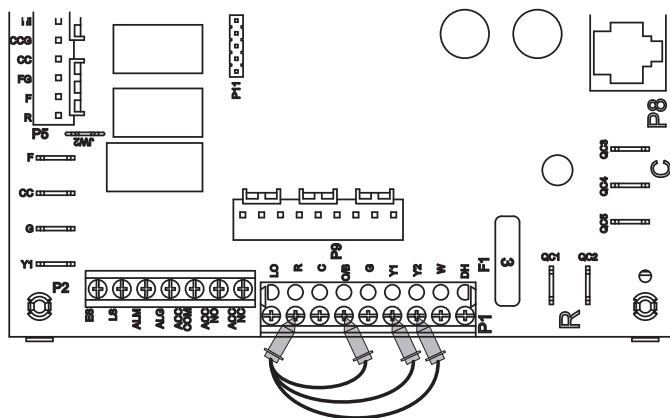

Troubleshooting

Should a major problem develop, refer to the following information for possible causes and corrective steps:

Compressor Won't Run

1. The fuse may be blown or the circuit breaker is open. Check electrical circuits and motor windings for shorts or grounds. Investigate for possible overloading. Replace fuse or reset circuit breakers after the fault is corrected.
2. Supply voltage may be too low. Check voltage with a volt meter.
3. Remote control system may be faulty. Check aquastat for correct wiring, setting and calibration. Check 24-volt transformer for burnout.
4. Wires may be loose or broken. Replace or tighten.
5. The low pressure switch may have tripped due to one or more of the following:
 - a. Fouled or plugged coaxial heat exchangers
 - b. Low or no water flow (source side heating, load side cooling)
 - c. Water too cold (source side heating)
 - d. Low refrigerant
6. The high pressure switch may have tripped due to one or more of the following:
 - a. Fouled or plugged coaxial heat exchanger
 - b. Low or no water flow (source side cooling, load side heating)
 - c. Water too warm (source side cooling)
7. Check the capacitor.
8. The compressor overload protection may be open. If the compressor dome is extremely hot, the overload will not reset until cooled down. If the overload does not reset when cool, it may be defective. If so, replace the compressor.

9. The internal winding of the compressor motor may be grounded to the compressor shell. If so, replace the compressor.
10. The compressor winding may be open. Check continuity with an ohm meter. If the winding is open, replace the compressor.

Insufficient Cooling or Heating

1. Check aquastat for improper location (secondary mode only).
2. Check for restriction in water flow.
3. Check subcooling for low refrigerant charge.
4. The reversing valve may be defective and creating a bypass of refrigerant. If the unit will not cool, check the reversing valve coil.
5. Check thermal expansion valve for possible restriction of refrigerant flow.

Noisy Unit Operation

1. Check compressor for loosened mounting bolts. Make sure compressor is floating free on its isolator mounts, and shipping bolt is removed from compressor plate.
2. Check for tubing contact with the compressor or other surfaces. Readjust it by bending slightly.
3. Check screws on all panels.
4. Check for chattering or humming in the contactor or relays due to low voltage or a defective holding coil. Replace the component.
5. Check for proper installation of vibration absorbing material under the unit. Unit must be fully supported, not just on corners.
6. Check for abnormally high discharge pressures.

Troubleshooting cont.

Heating Cycle Analysis

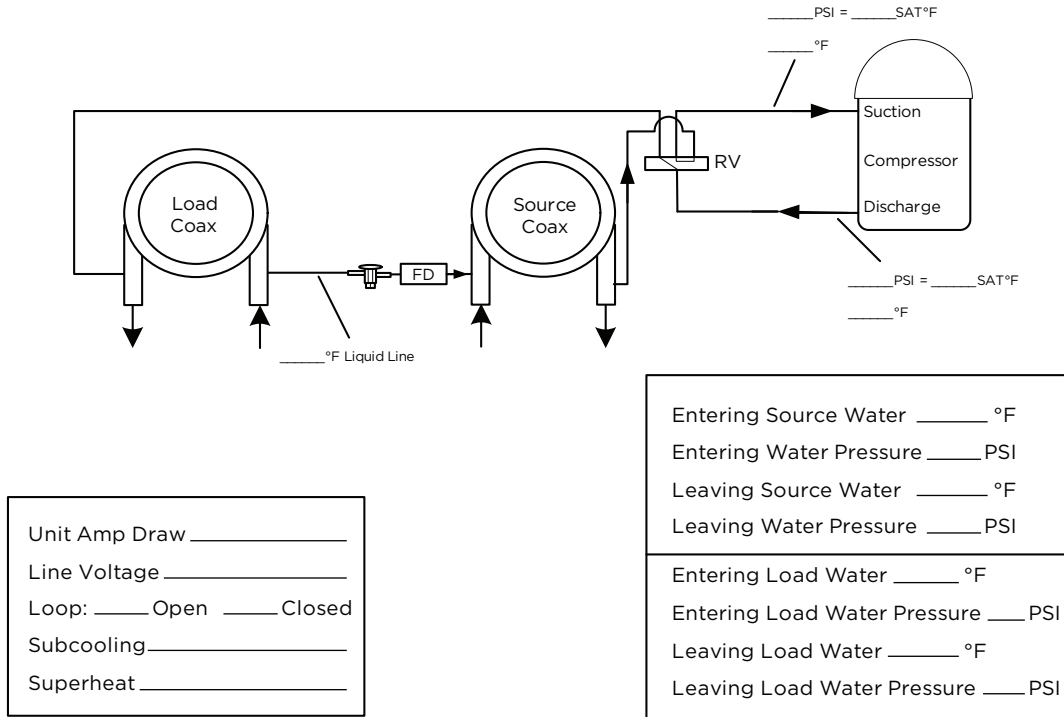

NOTE: Do not attach refrigerant gauges unless a problem is suspected!

Cooling Cycle Analysis

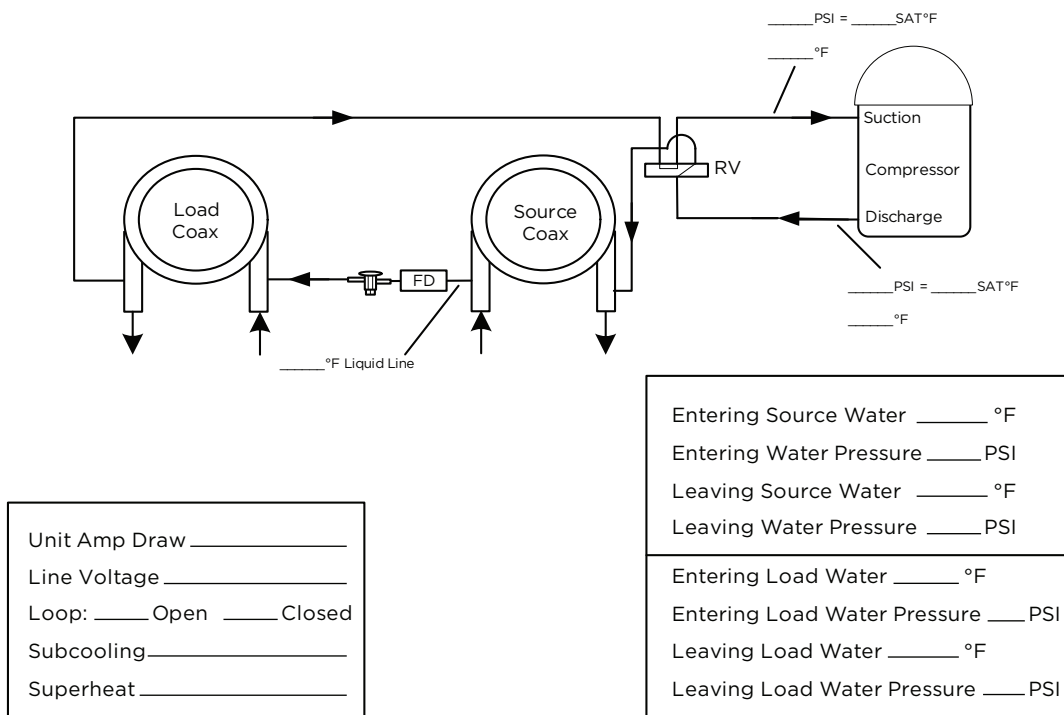

NOTE: Do not attach refrigerant gauges unless a problem is suspected!

Troubleshooting Form

Company Name: _____
 Technician Name: _____
 Model No: _____
 Owner's Name: _____
 Installation Address: _____

Company Phone No: _____
 Date: _____
 Serial No: _____
 Open or Closed Loop: _____
 Installation Date: _____

Check One

Start up/Check-out for new installation Troubleshooting Problem: _____

1. FLOW RATE IN GPM (SOURCE SIDE HEAT EXCHANGER)

Water In Pressure: a. _____ PSI
 Water Out Pressure: b. _____ PSI
 Pressure Drop = a - b c. _____ PSI
 Convert Pressure Drop to Flow Rate
 (refer to *Pressure Drop* table) d. _____ GPM

2. TEMPERATURE RISE OR DROP ACROSS SOURCE SIDE HEAT EXCHANGER

	COOLING	HEATING
Water In Temperature:	e. _____ °F	e. _____ °F
Water Out Temperature:	f. _____ °F	f. _____ °F
Temperature Difference:	g. _____ °F	g. _____ °F

3. TEMPERATURE RISE OR DROP ACROSS LOAD SIDE HEAT EXCHANGER

	COOLING	HEATING
Water In Temperature:	h. _____ °F	h. _____ °F
Water Out Temperature:	i. _____ °F	i. _____ °F
Temperature Difference:	j. _____ °F	j. _____ °F

4. HEAT OF REJECTION (HR) / HEAT OF EXTRACTION (HE) CALCULATION

HR or HE = Flow Rate x Temperature Difference x Brine Factor*
 d. (above) x g. (above) x 485 for Methanol or Environol, 500 for water*
 Heat of Extraction (Heating Mode) = _____ btu/hr
 Heat of Rejection (Cooling Mode) = _____ btu/hr
 Compare results to Capacity Data Tables

Note: Steps 5 through 8 need only be completed if a problem is suspected

5. WATTS

	COOLING	HEATING	HYDRONIC
Volts:	m. _____ VOLTS	m. _____ VOLTS	m. _____ VOLTS
Total Amps (Comp. + Fan):	n. _____ AMPS	n. _____ AMPS	n. _____ AMPS
Watts = m. x n. x 0.85	o. _____ WATTS	o. _____ WATTS	o. _____ WATTS

6. CAPACITY

Cooling Capacity = HR. - (o. x 3.413) p. _____ btu/hr
 Heating Capacity = HE. + (o. x 3.413) p. _____ btu/hr

7. EFFICIENCY

Cooling EER = p. / o. q. _____ EER
 Heating COP = p. / (o. x 3.413) q. _____ COP

8. SUPERHEAT (S.H.) / SUBCOOLING (S.C.)

	COOLING	HEATING	HYDRONIC
Suction Pressure:	r. _____ PSI	r. _____ PSI	r. _____ PSI
Suction Saturation Temperature:	s. _____ °F	s. _____ °F	s. _____ °F
Suction Line Temperature:	t. _____ °F	t. _____ °F	t. _____ °F
Superheat = t. - s.	u. _____ °F	u. _____ °F	u. _____ °F
Head Pressure:	v. _____ PSI	v. _____ PSI	v. _____ PSI
High Pressure Saturation Temp.:	w. _____ °F	w. _____ °F	w. _____ °F
Liquid Line Temperature*:	x. _____ °F	x. _____ °F	x. _____ °F
Subcooling = w. - x.	y. _____ °F	y. _____ °F	y. _____ °F

* Note: Liquid line is between the source heat exchanger and the expansion valve in the cooling mode; between the load heat exchanger and the expansion valve in the heating mode.

Performance Data

024 Heating

Source		Load Flow-4 GPM							Load Flow-5.5 GPM					Load Flow-7 GPM							
EST	Flow	10	LLT	HC	Power	HE	COP	LST	LLT	HC	Power	HE	COP	LST	LLT	HC	Power	HE	COP	LST	
° F	GPM	° F	° F	MBTUH	kW	MBTUH		° F	° F	MBTUH	kW	MBTUH		° F	° F	MBTUH	kW	MBTUH		° F	
25	5.5	60	Operation not recommended																		
		80	Operation not recommended																		
		100	Operation not recommended																		
		120	Operation not recommended																		
	7	60	70.8	20.9	1.29	16.5	4.75	20.1	67.9	21.1	1.27	16.7	4.86	20.1	66.2	21.2	1.25	16.9	4.97	20.0	
80		90.4	20.2	1.73	14.3	3.43	20.8	87.6	20.4	1.70	14.6	3.51	20.7	86.0	20.5	1.68	14.8	3.58	20.6		
100		110.1	19.6	2.16	12.2	2.65	21.4	107.4	19.7	2.13	12.4	2.70	21.3	105.8	19.8	2.10	12.6	2.76	21.3		
120		129.7	18.9	2.60	10.0	2.13	22.0	127.1	19.0	2.57	10.2	2.17	22.0	125.6	19.1	2.53	10.5	2.21	21.9		
30	4	60	71.8	22.9	1.21	18.8	5.55	20.3	50.6	22.6	1.23	18.4	5.39	20.5	29.5	22.3	1.25	18.0	5.23	20.7	
		80	91.3	21.8	1.66	16.2	3.85	21.7	88.8	21.7	1.67	16.0	3.80	21.8	86.4	21.6	1.68	15.8	3.76	21.8	
		100	110.7	20.8	2.12	13.5	2.87	23.0	108.4	20.8	2.11	13.6	2.88	23.0	106.1	20.8	2.11	13.6	2.89	23.0	
		120	130.2	19.7	2.57	10.9	2.25	24.4	128.0	19.9	2.56	11.2	2.28	24.2	125.9	20.1	2.54	11.4	2.32	24.1	
	5.5	60	71.9	23.0	1.26	18.7	5.35	22.4	60.0	23.0	1.25	18.8	5.39	22.4	48.2	23.1	1.25	18.8	5.42	22.5	
		80	91.4	22.0	1.71	16.2	3.79	23.4	88.9	22.1	1.69	16.3	3.84	23.4	86.5	22.1	1.67	16.4	3.89	23.4	
		100	110.9	21.1	2.15	13.7	2.87	24.5	108.5	21.1	2.12	13.9	2.92	24.4	106.2	21.2	2.09	14.1	2.98	24.4	
		120	130.4	20.1	2.60	11.2	2.27	25.5	128.2	20.2	2.55	11.5	2.32	25.4	126.0	20.3	2.51	11.7	2.37	25.3	
	7	60	71.9	23.1	1.31	18.6	5.17	24.5	69.5	23.5	1.28	19.1	5.40	24.4	67.0	23.8	1.24	19.6	5.62	24.2	
		80	91.5	22.2	1.75	16.3	3.73	25.2	89.1	22.5	1.70	16.7	3.88	25.1	86.7	22.7	1.65	17.0	4.03	25.0	
		100	111.0	21.4	2.18	13.9	2.87	25.9	108.7	21.5	2.12	14.2	2.97	25.8	106.3	21.5	2.06	14.5	3.06	25.7	
		120	130.6	20.5	2.62	11.6	2.29	26.6	128.3	20.5	2.55	11.8	2.36	26.5	126.0	20.4	2.47	12.0	2.42	26.5	
50	4	60	74.8	28.7	1.25	24.4	6.68	37.4	62.3	28.6	1.27	24.3	6.59	37.5	49.9	28.6	1.28	24.2	6.51	37.5	
		80	94.2	27.6	1.70	21.8	4.73	38.8	91.2	27.6	1.71	21.8	4.72	38.8	88.2	27.7	1.72	21.8	4.71	38.7	
		100	113.7	26.5	2.15	19.1	3.60	40.1	110.8	26.7	2.15	19.3	3.62	40.0	107.9	26.9	2.15	19.5	3.64	39.9	
		120	133.1	25.4	2.60	16.5	2.86	41.5	130.4	25.7	2.60	16.8	2.89	41.3	127.7	26.0	2.59	17.2	2.93	41.2	
	5.5	60	75.0	29.2	1.27	24.8	6.75	40.0	67.2	29.3	1.27	24.9	6.77	40.0	59.4	29.4	1.27	25.0	6.79	40.0	
		80	94.4	28.0	1.70	22.2	4.83	41.1	91.4	28.2	1.69	22.4	4.87	41.0	88.4	28.4	1.69	22.6	4.92	40.9	
		100	113.8	26.9	2.13	19.6	3.69	42.1	110.9	27.1	2.12	19.9	3.74	42.0	108.1	27.3	2.11	20.1	3.79	41.9	
		120	133.2	25.7	2.57	16.9	2.93	43.2	130.5	26.0	2.55	17.3	2.99	43.0	127.8	26.3	2.54	17.7	3.04	42.9	
	7	60	75.3	29.7	1.28	25.3	6.83	42.6	72.1	29.9	1.27	25.6	6.93	42.5	68.9	30.2	1.26	25.9	7.03	42.4	
		80	94.7	28.4	1.70	22.6	4.94	43.3	91.6	28.7	1.68	23.0	5.02	43.2	88.5	29.0	1.66	23.3	5.10	43.1	
		100	114.0	27.2	2.12	20.0	3.80	44.1	111.1	27.5	2.09	20.4	3.86	44.0	108.2	27.8	2.07	20.8	3.93	43.9	
		120	133.4	26.0	2.54	17.3	3.03	44.9	130.6	26.3	2.51	17.8	3.09	44.8	127.8	26.7	2.48	18.2	3.15	44.6	
70	4	60	77.7	34.4	1.29	30.0	7.81	54.5	74.0	34.6	1.30	30.2	7.80	54.5	70.3	34.8	1.31	30.3	7.78	54.4	
		80	97.2	33.3	1.74	27.4	5.62	55.9	93.6	33.6	1.75	27.6	5.64	55.8	90.0	33.8	1.75	27.8	5.65	55.6	
		100	116.6	32.2	2.18	24.7	4.32	57.2	113.1	32.5	2.19	25.1	4.35	57.1	109.7	32.9	2.20	25.4	4.38	56.9	
		120	136.0	31.1	2.63	22.1	3.46	58.6	132.7	31.5	2.64	22.5	3.50	58.4	129.4	31.9	2.64	22.9	3.54	58.2	
	5.5	60	78.2	35.3	1.27	31.0	8.14	57.6	74.4	35.5	1.28	31.1	8.13	57.5	70.5	35.7	1.29	31.3	8.11	57.4	
		80	97.5	34.0	1.69	28.2	5.88	58.7	93.9	34.3	1.70	28.5	5.89	58.6	90.2	34.6	1.72	28.7	5.91	58.5	
		100	116.8	32.6	2.12	25.4	4.52	59.8	113.3	33.1	2.13	25.8	4.55	59.6	109.9	33.5	2.14	26.2	4.59	59.5	
		120	136.1	31.3	2.54	22.6	3.61	60.9	132.8	31.9	2.55	23.1	3.66	60.7	129.5	32.4	2.57	23.6	3.70	60.5	
	7	60	78.7	36.2	1.25	31.9	8.49	60.6	74.7	36.4	1.26	32.1	8.46	60.5	70.8	36.6	1.27	32.3	8.44	60.5	
		80	97.9	34.6	1.65	29.0	6.15	61.5	94.1	35.0	1.66	29.3	6.17	61.4	90.4	35.4	1.68	29.6	6.18	61.3	
		100	117.0	33.1	2.05	26.1	4.73	62.3	113.5	33.6	2.07	26.5	4.76	62.2	110.1	34.1	2.08	27.0	4.80	62.0	
		120	136.2	31.5	2.45	23.1	3.77	63.2	133.0	32.2	2.47	23.8	3.82	63.0	129.7	32.9	2.49	24.4	3.87	62.8	
90	4	60	81.0	40.8	1.42	36.0	8.42	71.5	76.6	41.1	1.38	36.4	8.76	71.3	72.2	41.3	1.33	36.8	9.10	71.1	
		80	100.7	40.1	1.83	33.8	6.41	72.6	96.3	40.3	1.77	34.2	6.68	72.4	91.9	40.4	1.71	34.6	6.94	72.2	
		100	Operation not recommended																		
		120	Operation not recommended																		
	5.5	60	81.6	41.9	1.43	37.0	8.60	75.1	77.0	42.1	1.38	37.4	8.93	75.0	72.5	42.3	1.34	37.7	9.28	74.8	
		80	101.2	41.2	1.84	34.9	6.56	76.0	96.7	41.3	1.78	35.2	6.81	75.8	92.2	41.5	1.72	35.6	7.08	75.7	
		100	Operation not recommended																		
		120	Operation not recommended																		
	7	60	82.1	42.9	1.43	38.0	8.79	78.8	77.4	43.1	1.39	38.4	9.13	78.7	72.8	43.3	1.34	38.7	9.47	78.6	
		80	101.8	42.2	1.84	35.9	6.71	79.4	97.1	42.4	1.79	36.3	6.96	79.3	92.5	42.5	1.73	36.6	7.21	79.2	
		100	Operation not recommended																		
		120	Operation not recommended																		

EST = entering source fluid temperature to heat pump
 HC = total heating capacity in MBTUH
 ELT = entering load fluid temperature to heat pump
 HE = heat extracted in MBTUH
 LST = leaving source fluid temperature from heat pump
 COP = coefficient of performance
 LLT = leaving load fluid temperature from heat pump

Performance Data cont.

024 Heating Vented Load Coax

Source		Load Flow-4 GPM							Load Flow-5.5 GPM							Load Flow-7 GPM						
EST	Flow	10	LLT	HC	Power	HE	COP	LST	LLT	HC	Power	HE	COP	LST	LLT	HC	Power	HE	COP	LST		
° F	GPM	° F	° F	MBTUH	kW	MBTUH		° F	° F	MBTUH	kW	MBTUH		° F	° F	MBTUH	kW	MBTUH		° F		
25	5.5	60	Operation not recommended																			
		80	Operation not recommended																			
		100	Operation not recommended																			
		120	Operation not recommended																			
30	4	60	71.0	21.3	1.33	16.8	4.69	20.1	68.0	21.4	1.34	16.8	4.70	20.0	66.3	21.5	1.34	16.9	4.70	20.0		
		80	90.6	20.6	1.79	14.5	3.38	20.7	87.7	20.6	1.79	14.5	3.38	20.7	86.1	20.7	1.79	14.6	3.39	20.7		
		100	110.3	19.9	2.24	12.2	2.60	21.4	107.4	19.9	2.24	12.2	2.60	21.4	105.8	19.8	2.23	12.2	2.60	21.4		
		120	129.9	19.2	2.70	10.0	2.08	22.1	127.2	19.1	2.69	9.9	2.08	22.1	125.6	19.0	2.68	9.9	2.08	22.1		
	30	5.5	60	71.9	23.0	1.35	18.4	5.01	22.6	60.1	23.2	1.33	18.7	5.13	22.5	48.3	23.5	1.31	19.0	5.24	22.4	
			80	91.4	22.1	1.79	16.0	3.62	23.5	89.0	22.4	1.77	16.3	3.70	23.4	86.7	22.7	1.76	16.6	3.77	23.3	
			100	110.9	21.2	2.24	13.6	2.78	24.5	108.7	21.5	2.22	14.0	2.84	24.4	106.4	21.9	2.21	14.3	2.90	24.2	
			120	130.5	20.4	2.68	11.2	2.22	25.5	128.3	20.7	2.67	11.6	2.27	25.3	126.2	21.1	2.66	12.0	2.32	25.2	
		30	7	60	72.0	23.3	1.37	18.6	4.98	24.5	69.5	23.6	1.32	19.1	5.25	24.4	67.0	23.9	1.27	19.6	5.51	24.2
				80	91.5	22.3	1.78	16.2	3.66	25.2	89.1	22.6	1.76	16.6	3.78	25.1	86.8	23.0	1.73	17.1	3.90	25.0
				100	111.0	21.3	2.20	13.8	2.84	25.9	108.7	21.7	2.19	14.2	2.90	25.8	106.5	22.0	2.18	14.6	2.96	25.7
				120	130.5	20.3	2.61	11.4	2.28	26.6	128.3	20.7	2.63	11.7	2.31	26.5	126.2	21.1	2.64	12.1	2.34	26.4
50			4	60	74.6	28.4	1.39	23.7	5.94	37.8	62.2	28.6	1.38	23.9	6.06	37.7	49.8	28.9	1.37	24.2	6.18	37.5
				80	94.1	27.4	1.86	21.0	4.28	39.2	91.2	27.6	1.85	21.3	4.35	39.0	88.2	27.8	1.84	21.6	4.42	38.9
				100	113.6	26.4	2.34	18.4	3.29	40.5	110.7	26.6	2.32	18.7	3.34	40.4	107.9	26.8	2.31	18.9	3.39	40.2
				120	133.1	25.4	2.81	15.8	2.64	41.9	130.3	25.6	2.79	16.0	2.67	41.7	127.6	25.8	2.78	16.3	2.70	41.6
	50	5.5	60	75.0	29.1	1.41	24.3	6.06	40.2	67.2	29.3	1.37	24.6	6.29	40.1	59.4	29.6	1.33	25.0	6.53	40.0	
			80	94.4	27.9	1.85	21.5	4.40	41.3	91.4	28.1	1.82	21.9	4.52	41.2	88.3	28.3	1.79	22.2	4.63	41.1	
			100	113.7	26.7	2.30	18.8	3.39	42.4	110.9	26.9	2.28	19.1	3.45	42.3	108.0	27.1	2.26	19.4	3.52	42.2	
			120	133.1	25.5	2.75	16.1	2.71	43.5	130.4	25.7	2.74	16.3	2.75	43.4	127.6	25.9	2.73	16.6	2.78	43.3	
		50	7	60	75.3	29.7	1.42	24.9	6.09	42.7	72.1	30.0	1.35	25.4	6.49	42.5	68.9	30.3	1.29	25.9	6.88	42.4
				80	94.6	28.3	1.84	22.0	4.47	43.5	91.5	28.6	1.80	22.5	4.64	43.4	88.5	28.9	1.75	22.9	4.82	43.3
				100	113.9	26.9	2.27	19.2	3.46	44.3	111.0	27.2	2.24	19.6	3.54	44.2	108.1	27.5	2.22	19.9	3.62	44.1
				120	133.2	25.6	2.69	16.4	2.77	45.2	130.4	25.8	2.69	16.7	2.80	45.1	127.7	26.1	2.69	16.9	2.84	45.0
70	4	60	77.6	34.1	1.46	29.1	6.84	55.0	73.9	34.4	1.42	29.6	7.11	54.8	70.2	34.7	1.38	30.0	7.37	54.5		
		80	96.9	32.9	1.93	26.3	4.99	56.5	93.4	33.1	1.91	26.6	5.09	56.3	89.8	33.3	1.88	26.9	5.19	56.1		
		100	116.3	31.6	2.40	23.4	3.86	57.9	112.9	31.8	2.39	23.6	3.89	57.8	109.4	31.9	2.38	23.8	3.93	57.7		
		120	135.7	30.4	2.87	20.6	3.10	59.4	132.3	30.5	2.88	20.6	3.10	59.4	129.0	30.5	2.88	20.7	3.10	59.3		
	70	5.5	60	78.1	35.1	1.47	30.1	7.02	57.9	74.3	35.4	1.40	30.6	7.39	57.7	70.5	35.7	1.34	31.1	7.80	57.5	
			80	97.3	33.6	1.92	27.1	5.14	59.1	93.7	33.8	1.87	27.4	5.29	59.0	90.0	34.0	1.83	27.8	5.45	58.8	
			100	116.5	32.1	2.37	24.0	3.97	60.3	113.0	32.3	2.34	24.3	4.03	60.2	109.5	32.4	2.32	24.5	4.10	60.2	
			120	135.8	30.6	2.82	21.0	3.18	61.5	132.4	30.7	2.81	21.1	3.20	61.5	129.1	30.8	2.81	21.2	3.22	61.5	
		70	7	60	78.6	36.1	1.47	31.1	7.20	60.8	74.7	36.4	1.39	31.6	7.72	60.7	70.8	36.6	1.30	32.2	8.25	60.5
				80	97.7	34.3	1.90	27.8	5.29	61.8	94.0	34.6	1.84	28.3	5.51	61.7	90.2	34.8	1.78	28.7	5.73	61.5
				100	116.8	32.6	2.34	24.6	4.08	62.8	113.2	32.8	2.30	24.9	4.18	62.7	109.7	32.9	2.25	25.2	4.28	62.6
				120	135.9	30.8	2.77	21.3	3.26	63.7	132.5	31.0	2.75	21.6	3.30	63.6	129.2	31.1	2.73	21.8	3.34	63.6
90	4	Operation not recommended																				
	5.5	Operation not recommended																				
	7	Operation not recommended																				

EST = entering source fluid temperature to heat pump
 HC = total heating capacity in MBTUH
 ELT = entering load fluid temperature to heat pump
 HE = heat extracted in MBTUH
 LST = leaving source fluid temperature from heat pump
 COP = coefficient of performance
 LLT = leaving load fluid temperature from heat pump

8/29/24

Performance Data cont.

024 Cooling

Source		Load Flow-4 GPM							Load Flow-5.5 GPM							Load Flow-7 GPM						
EST ° F	Flow GPM	ELT ° F	LLT ° F	TC MBTUH	Power kW	HR MBTUH	EER	LST ° F	LLT ° F	TC MBTUH	Power kW	HR MBTUH	EER	LST ° F	LLT ° F	TC MBTUH	Power kW	HR MBTUH	EER	LST ° F		
30	4	50	36.0	27.1	0.86	30.0	31.51	45.5	35.7	27.7	0.89	30.7	31.31	45.8	35.4	28.3	0.91	31.4	31.10	46.2		
		70	54.8	29.6	0.87	32.5	33.98	46.8	54.5	30.0	0.89	33.1	33.63	47.1	54.3	30.5	0.92	33.6	33.27	47.3		
		90	73.5	32.0	0.88	35.0	36.40	48.1	73.3	32.4	0.90	35.4	35.91	48.3	73.1	32.7	0.92	35.9	35.42	48.5		
		110	92.2	34.5	0.89	37.5	38.76	49.3	92.1	34.7	0.91	37.8	38.15	49.5	92.0	34.9	0.93	38.1	37.53	49.6		
	5.5	50	39.2	26.5	0.81	29.3	32.72	41.9	39.0	27.0	0.83	29.8	32.57	42.2	38.8	27.4	0.85	30.3	32.43	42.4		
		70	58.4	28.4	0.84	31.3	34.05	42.8	58.2	28.8	0.85	31.7	33.79	43.0	58.0	29.2	0.87	32.2	33.54	43.2		
		90	77.5	30.4	0.86	33.3	35.31	43.7	77.4	30.7	0.88	33.7	34.95	43.8	77.3	31.0	0.90	34.0	34.60	44.0		
		110	96.7	32.3	0.89	35.3	36.50	44.5	96.6	32.5	0.90	35.6	36.04	44.7	96.5	32.8	0.92	35.9	35.60	44.8		
	7	50	42.4	25.9	0.76	28.5	34.08	38.4	42.3	26.2	0.77	28.8	34.03	38.5	42.2	26.5	0.78	29.2	33.97	38.6		
		70	62.0	27.3	0.80	30.0	34.13	38.8	61.9	27.6	0.81	30.4	33.99	38.9	61.8	27.9	0.82	30.7	33.85	39.0		
		90	81.5	28.7	0.84	31.6	34.17	39.3	81.5	29.0	0.85	31.9	33.95	39.4	81.4	29.2	0.87	32.2	33.73	39.5		
		110	101.1	30.1	0.88	33.1	34.20	39.8	101.1	30.4	0.90	33.4	33.92	39.8	101.0	30.6	0.91	33.7	33.63	39.9		
50	4	50	36.7	25.9	1.14	29.7	24.48	65.3	36.2	26.7	1.18	30.7	24.42	65.8	35.8	27.6	1.22	31.7	24.37	66.3		
		70	54.6	30.0	1.16	33.9	27.42	67.5	54.2	30.6	1.20	34.7	27.16	67.9	53.9	31.3	1.24	35.5	26.91	68.3		
		90	72.4	34.1	1.19	38.2	30.22	69.7	72.2	34.6	1.23	38.7	29.80	70.0	72.0	35.0	1.26	39.3	29.37	70.3		
		110	90.3	38.2	1.22	42.4	32.90	71.8	90.2	38.5	1.25	42.7	32.32	72.0	90.0	38.8	1.29	43.1	31.75	72.2		
	5.5	50	39.6	25.6	1.11	29.3	23.07	61.9	39.3	26.2	1.12	30.0	23.40	62.2	39.0	26.9	1.13	30.7	23.73	62.6		
		70	58.0	29.4	1.14	33.3	25.88	63.6	57.8	29.9	1.15	33.9	25.94	63.8	57.6	30.5	1.17	34.5	26.00	64.1		
		90	76.4	33.3	1.16	37.2	28.56	65.2	76.3	33.7	1.19	37.7	28.34	65.4	76.1	34.1	1.21	38.2	28.13	65.6		
		110	94.9	37.1	1.19	41.2	31.11	66.8	94.7	37.4	1.22	41.5	30.60	67.0	94.6	37.7	1.25	41.9	30.12	67.1		
	7	50	42.6	25.3	1.08	28.9	25.83	58.5	42.4	25.7	1.07	29.4	26.31	58.6	42.3	26.2	1.05	29.8	26.80	58.8		
		70	61.5	28.8	1.11	32.6	27.78	59.6	61.4	29.2	1.11	33.0	28.02	59.7	61.3	29.7	1.11	33.4	28.26	59.8		
		90	80.5	32.4	1.14	36.3	29.69	60.7	80.4	32.8	1.15	36.7	29.64	60.8	80.3	33.1	1.16	37.1	29.58	60.9		
		110	99.4	36.0	1.17	40.0	31.55	61.8	99.3	36.3	1.19	40.3	31.17	61.9	99.2	36.6	1.22	40.7	30.79	62.0		
70	4	50	37.3	24.6	1.41	29.4	17.45	85.2	36.8	25.7	1.47	30.7	17.54	85.8	36.2	26.8	1.52	32.0	17.63	86.5		
		70	54.3	30.4	1.46	35.3	20.85	88.2	53.9	31.2	1.51	36.4	20.70	88.7	53.5	32.1	1.56	37.4	20.56	89.3		
		90	71.4	36.1	1.50	41.3	24.04	91.3	71.1	36.7	1.55	42.0	23.68	91.7	70.8	37.3	1.60	42.8	23.33	92.1		
		110	Operation not recommended																			
	5.5	50	40.0	24.6	1.41	29.4	17.51	81.9	39.7	25.5	1.41	30.3	18.04	82.3	39.3	26.4	1.42	31.2	18.56	82.7		
		70	57.7	30.4	1.44	35.3	21.14	84.3	57.4	31.1	1.46	36.0	21.35	84.6	57.1	31.8	1.47	36.8	21.55	85.0		
		90	75.4	36.1	1.47	41.1	24.61	86.7	75.1	36.6	1.50	41.8	24.47	86.9	74.9	37.2	1.53	42.4	24.33	87.2		
		110	Operation not recommended																			
	7	50	42.8	24.6	1.40	29.4	17.57	78.7	42.6	25.3	1.36	29.9	18.60	78.8	42.4	25.9	1.32	30.4	19.62	79.0		
		70	61.1	30.4	1.42	35.2	21.44	80.4	60.9	30.9	1.40	35.7	22.05	80.5	60.7	31.4	1.39	36.2	22.67	80.7		
		90	79.4	36.1	1.43	41.0	25.21	82.1	79.2	36.6	1.44	41.5	25.32	82.2	79.1	37.0	1.45	41.9	25.44	82.3		
		110	97.7	41.9	1.45	46.8	28.90	83.8	97.6	42.2	1.49	47.3	28.43	83.9	97.5	42.5	1.52	47.7	27.96	84.0		
90	4	50	38.9	21.5	1.85	27.8	12.74	104.3	38.3	22.6	1.91	29.1	12.93	105.0	37.8	23.8	1.97	30.5	13.11	105.7		
		70	55.7	27.8	1.91	34.3	15.76	107.7	55.2	28.8	1.96	35.5	15.83	108.3	54.7	29.8	2.00	36.6	15.89	108.9		
		90	Operation not recommended																			
		110	Operation not recommended																			
	5.5	50	41.3	21.4	1.84	27.6	11.63	101.2	40.9	22.3	1.86	28.7	12.03	101.7	40.5	23.3	1.88	29.7	12.41	102.1		
		70	58.8	27.7	1.87	34.1	14.79	103.8	58.4	28.5	1.89	35.0	15.06	104.2	58.1	29.4	1.92	35.9	15.32	104.6		
		90	Operation not recommended																			
		110	Operation not recommended																			
	7	50	43.7	21.3	1.83	27.5	12.76	98.1	43.5	22.1	1.81	28.2	13.48	98.3	43.3	22.9	1.79	29.0	14.19	98.5		
		70	61.9	27.6	1.84	33.9	16.23	100.0	61.7	28.3	1.83	34.5	16.69	100.2	61.5	29.0	1.83	35.2	17.16	100.4		
		90	Operation not recommended																			
		110	Operation not recommended																			
110	4	50	40.5	18.4	2.29	26.2	8.03	123.5	39.9	19.6	2.35	27.6	8.31	124.2	39.3	20.7	2.41	28.9	8.59	124.9		
		70	57.0	25.2	2.36	33.3	10.68	127.2	56.4	26.3	2.40	34.5	10.95	127.8	55.9	27.4	2.44	35.8	11.23	128.4		
		90	Operation not recommended																			
		110	Operation not recommended																			
	5.5	50	42.6	18.2	2.27	25.9	8.00	120.5	42.2	19.2	2.30	27.1	8.34	121.0	41.7	20.3	2.34	28.2	8.67	121.5		
		70	59.8	25.0	2.31	32.9	10.84	123.4	59.4	26.0	2.33	34.0	11.14	123.8	59.0	27.0	2.36	35.0	11.43	124.3		
		90	Operation not recommended																			
		110	Operation not recommended																			
	7	50	44.7	17.9	2.25	25.6	7.96	117.5	44.4	18.9	2.26	26.5	8.36	117.8	44.2	19.8	2.26	27.5	8.76	118.1		
		70	62.7	24.8	2.25	32.5	11.02	119.6	62.4	25.7	2.26	33.4	11.3	119.8	62.2	26.5	2.27	34.2	11.64	120.1		
		90	Operation not recommended																			
		110	Operation not recommended																			

EST = entering source fluid temperature to heat pump
 TC = total cooling capacity in MBTUH
 ELT = entering load fluid temperature to heat pump
 HR = heat rejected in MBTUH
 LST = leaving source fluid temperature from heat pump
 EER = energy efficiency ratio
 LLT = leaving load fluid temperature from heat pump

08/29/24

Performance Data cont.

048 Heating

Source		Load Flow-8 GPM							Load Flow-11.5 GPM							Load Flow-15 GPM						
EST ° F	Flow GPM	ELT ° F	LLT ° F	HC MBTUH	Power kW	HE MBTUH	COP	LST ° F	LLT ° F	HC MBTUH	Power kW	HE MBTUH	COP	LST ° F	LLT ° F	HC MBTUH	Power kW	HE MBTUH	COP	LST ° F		
25	11.5	60	Operation not recommended																			
		80	Operation not recommended																			
		100	Operation not recommended																			
		120	Operation not recommended																			
	15	60	70.8	41.9	2.44	33.6	5.03	20.4	67.5	42.0	2.43	33.7	5.06	20.4	65.8	42.0	2.42	33.7	5.09	20.4		
		80	90.5	40.9	3.34	29.5	3.58	21.0	87.3	40.7	3.30	29.5	3.61	21.0	85.6	40.6	3.26	29.5	3.65	21.0		
		100	110.3	39.8	4.25	25.3	2.75	21.5	107.1	39.5	4.18	25.3	2.77	21.5	105.4	39.2	4.11	25.2	2.80	21.5		
		120	130.0	38.8	5.15	21.2	2.21	22.1	126.9	38.3	5.05	21.1	2.22	22.1	125.2	37.8	4.95	20.9	2.24	22.1		
30	8	60	71.3	43.9	2.42	35.6	5.32	20.8	60.6	44.1	2.47	35.6	5.23	20.8	50.0	44.2	2.52	35.6	5.14	20.8		
		80	91.1	43.0	3.35	31.6	3.76	21.9	88.5	43.1	3.35	31.6	3.76	21.9	85.9	43.1	3.35	31.7	3.77	21.8		
		100	110.9	42.1	4.28	27.5	2.88	22.9	108.3	42.1	4.23	27.6	2.91	22.9	105.8	42.0	4.19	27.7	2.94	22.9		
		120	130.6	41.2	5.21	23.4	2.32	24.0	128.1	41.1	5.12	23.6	2.35	23.9	125.6	40.9	5.02	23.8	2.39	23.9		
	11.5	60	71.8	45.8	2.52	37.2	5.33	22.7	65.0	45.9	2.49	37.4	5.39	22.7	58.3	46.0	2.47	37.6	5.46	22.7		
		80	91.4	44.4	3.41	32.7	3.81	23.6	88.8	44.4	3.36	32.9	3.87	23.6	86.1	44.4	3.32	33.1	3.93	23.5		
		100	111.1	43.0	4.31	28.3	2.92	24.5	108.5	42.9	4.23	28.5	2.97	24.4	105.9	42.9	4.16	28.7	3.02	24.4		
		120	130.7	41.6	5.20	23.8	2.34	25.3	128.2	41.4	5.10	24.0	2.38	25.3	125.7	41.3	5.01	24.2	2.42	25.2		
	15	60	72.3	47.6	2.61	38.7	5.34	24.7	69.4	47.7	2.52	39.1	5.57	24.6	66.6	47.8	2.42	39.5	5.79	24.6		
		80	91.8	45.7	3.47	33.9	3.86	25.3	89.0	45.7	3.37	34.2	3.98	25.3	86.3	45.8	3.28	34.6	4.09	25.2		
		100	111.3	43.8	4.33	29.0	2.96	26.0	108.7	43.8	4.23	29.3	3.03	26.0	106.0	43.7	4.13	29.6	3.10	25.9		
		120	130.8	41.9	5.19	24.2	2.37	26.7	128.3	41.8	5.09	24.4	2.41	26.6	125.7	41.7	4.99	24.7	2.45	26.6		
50	8	60	74.7	56.9	2.53	48.3	6.54	37.6	67.2	56.8	2.52	48.2	6.60	37.6	59.8	56.8	2.50	48.2	6.66	37.6		
		80	94.1	54.8	3.42	43.1	4.68	38.9	90.8	54.8	3.38	43.2	4.75	38.9	87.5	54.7	3.34	43.3	4.81	38.8		
		100	113.6	52.7	4.31	38.0	3.58	40.2	110.4	52.7	4.24	38.2	3.64	40.2	107.2	52.7	4.17	38.4	3.70	40.1		
		120	133.0	50.6	5.20	32.9	2.86	41.5	130.0	50.6	5.10	33.2	2.91	41.4	127.0	50.6	5.01	33.5	2.96	41.4		
	11.5	60	75.2	59.1	2.59	50.2	6.69	40.2	69.6	58.9	2.53	50.3	6.83	40.2	64.1	58.8	2.47	50.3	6.98	40.2		
		80	94.5	56.4	3.45	44.7	4.80	41.3	91.1	56.3	3.37	44.8	4.89	41.2	87.7	56.2	3.30	45.0	4.99	41.2		
		100	113.9	53.8	4.31	39.1	3.66	42.3	110.6	53.8	4.22	39.4	3.73	42.3	107.4	53.7	4.14	39.6	3.81	42.2		
		120	133.2	51.2	5.17	33.5	2.90	43.4	130.1	51.2	5.07	33.9	2.96	43.3	127.0	51.2	4.97	34.2	3.02	43.3		
	15	60	75.8	61.3	2.65	52.2	6.77	42.8	72.1	61.0	2.54	52.3	7.03	42.8	68.4	60.8	2.44	52.4	7.30	42.8		
		80	95.0	58.1	3.48	46.2	4.90	43.6	91.5	57.9	3.37	46.4	5.04	43.6	87.9	57.8	3.27	46.6	5.18	43.6		
		100	114.2	54.9	4.31	40.2	3.74	44.5	110.8	54.9	4.20	40.5	3.83	44.4	107.5	54.8	4.10	40.8	3.92	44.4		
		120	133.3	51.8	5.14	34.2	2.96	45.3	130.2	51.8	5.04	34.6	3.02	45.2	127.1	51.8	4.94	35.0	3.08	45.2		
70	8	60	78.0	69.9	2.64	60.9	7.76	54.3	73.8	69.6	2.56	60.9	7.97	54.3	69.5	69.3	2.48	60.8	8.19	54.3		
		80	97.2	66.6	3.49	54.7	5.60	55.9	93.1	66.5	3.40	54.8	5.73	55.9	89.1	66.3	3.32	55.0	5.86	55.8		
		100	116.3	63.3	4.33	48.5	4.28	57.5	112.5	63.3	4.24	48.8	4.37	57.4	108.7	63.3	4.15	49.1	4.47	57.3		
		120	135.5	60.0	5.18	42.3	3.39	59.1	131.9	60.2	5.09	42.8	3.47	59.0	128.3	60.3	4.99	43.3	3.54	58.8		
	11.5	60	78.7	72.4	2.66	63.3	7.97	57.6	74.2	72.0	2.56	63.2	8.23	57.7	69.8	71.5	2.47	63.1	8.50	57.7		
		80	97.7	68.5	3.48	56.6	5.76	58.9	93.5	68.3	3.39	56.7	5.91	58.9	89.4	68.0	3.29	56.8	6.06	58.9		
		100	116.7	64.7	4.31	50.0	4.40	60.2	112.8	64.6	4.21	50.3	4.50	60.2	108.9	64.6	4.11	50.5	4.60	60.1		
		120	135.7	60.8	5.13	43.3	3.47	61.5	132.0	61.0	5.03	43.8	3.55	61.4	128.4	61.1	4.94	44.3	3.63	61.3		
	15	60	79.3	74.9	2.68	65.8	8.19	61.0	74.7	74.3	2.57	65.5	8.50	61.0	70.1	73.7	2.45	65.3	8.81	61.0		
		80	98.2	70.5	3.48	58.6	5.93	61.9	93.9	70.1	3.37	58.6	6.10	61.9	89.6	69.8	3.26	58.6	6.27	61.9		
		100	117.0	66.0	4.28	51.4	4.52	62.9	113.0	65.9	4.18	51.7	4.63	62.9	109.0	65.8	4.07	51.9	4.74	62.9		
		120	135.9	61.6	5.08	44.3	3.55	63.9	132.2	61.8	4.98	44.8	3.63	63.8	128.5	61.9	4.88	45.2	3.72	63.8		
90	8	60	81.1	81.9	2.78	72.4	8.63	71.3	75.9	79.8	3.46	68.0	7.07	72.5	70.7	77.7	4.14	63.6	5.50	73.6		
		80	99.9	77.4	3.64	65.0	6.24	73.3	95.1	76.1	4.04	62.3	5.58	73.9	90.3	74.8	4.44	59.6	4.93	74.6		
		100	118.8	72.9	4.49	57.6	4.75	75.2	114.3	72.4	4.62	56.6	4.59	75.4	109.9	71.8	4.75	55.6	4.43	75.7		
		120	Operation not recommended																			
	11.5	60	81.5	83.6	2.79	74.1	8.80	75.5	76.2	81.2	3.06	70.7	7.77	76.2	70.8	78.8	3.34	67.4	6.91	76.9		
		80	100.5	79.5	3.65	67.0	6.37	76.9	95.5	77.7	3.78	64.8	6.03	77.3	90.4	76.0	3.91	62.7	5.70	77.8		
		100	119.4	75.3	4.52	59.9	4.88	78.3	114.7	74.3	4.50	58.9	4.84	78.5	110.1	73.2	4.47	58.0	4.80	78.7		
		120	Operation not recommended																			
	15	60	82.0	85.3	2.79	75.8	8.96	79.6	76.5	82.6	2.67	73.5	9.09	79.9	71.0	79.9	2.54	71.2	9.22	80.2		
		80	101.0	81.5	3.67	69.0	6.51	80.5	95.8	79.4	3.52	67.4	6.62	80.7	90.6	77.3	3.37	65.8	6.72	81.0		
		100	120.0	77.8	4.55	62.2	5.01	81.4	115.2	76.2	4.37	61.3	5.11	81.6	110.3	74.6	4.19	60.3	5.21	81.7		
		120	Operation not recommended																			

EST = entering source fluid temperature to heat pump
 HC = total heating capacity in MBTUH
 ELT = entering load fluid temperature to heat pump
 HE = heat extracted in MBTUH
 LST = leaving source fluid temperature from heat pump
 COP = coefficient of performance
 LLT = leaving load fluid temperature from heat pump

Performance Data cont.

048 Cooling

Source		Load Flow-8 GPM							Load Flow-11.5 GPM					Load Flow-15 GPM								
EST ° F	Flow GPM	ELT ° F	LLT ° F	TC MBTUH	Power kW	HR MBTUH	EER	LST ° F	LLT ° F	TC MBTUH	Power kW	HR MBTUH	EER	LST ° F	LLT ° F	TC MBTUH	Power kW	HR MBTUH	EER	LST ° F		
30	8	50	36.5	52.3	1.88	58.7	27.82	45.1	39.4	54.1	1.94	60.7	27.93	45.6	42.3	55.8	1.99	62.6	28.04	46.1		
		70	55.4	56.5	1.92	63.0	29.48	46.2	58.7	57.7	1.96	64.4	29.43	46.6	61.9	59.0	2.01	65.8	29.39	47.0		
		90	74.4	60.7	1.95	67.4	31.08	47.4	77.9	61.4	1.99	68.2	30.89	47.6	81.5	62.1	2.02	69.0	30.71	47.8		
		110	93.3	64.9	1.99	71.7	32.61	48.5	97.1	65.1	2.02	72.0	32.31	48.6	101.0	65.3	2.04	72.3	32.01	48.6		
	11.5	50	36.3	53.2	1.85	59.5	28.76	41.7	39.3	54.8	1.89	61.3	28.99	42.1	42.2	56.4	1.93	63.0	29.22	42.4		
		70	55.5	56.4	1.87	62.8	30.15	42.4	58.7	57.5	1.90	64.0	30.25	42.7	61.9	58.6	1.93	65.2	30.35	42.9		
		90	74.6	59.7	1.89	66.1	31.51	43.1	78.1	60.3	1.91	66.8	31.50	43.3	81.6	60.9	1.93	67.5	31.48	43.4		
		110	93.8	62.9	1.92	69.4	32.85	43.9	97.6	63.0	1.93	69.6	32.73	43.9	101.3	63.1	1.94	69.7	32.61	43.9		
	15	50	36.1	54.1	1.82	60.3	29.73	38.3	39.1	55.6	1.85	61.8	30.10	38.5	42.2	57.0	1.87	63.4	30.48	38.7		
		70	55.5	56.4	1.83	62.6	30.86	38.6	58.7	57.3	1.84	63.6	31.13	38.7	62.0	58.3	1.86	64.6	31.40	38.9		
		90	74.9	58.6	1.83	64.9	31.98	38.9	78.3	59.1	1.84	65.4	32.16	39.0	81.8	59.6	1.84	65.9	32.33	39.1		
		110	94.3	60.9	1.84	67.2	33.10	39.2	98.0	60.9	1.84	67.2	33.19	39.2	101.6	60.9	1.83	67.1	33.28	39.2		
50	8	50	37.4	49.1	2.44	57.4	21.57	64.8	40.0	51.2	2.48	59.7	21.97	65.4	42.7	53.4	2.52	62.0	22.36	66.0		
		70	55.5	56.5	2.51	65.0	23.85	66.8	58.6	58.2	2.54	66.9	24.15	67.2	61.7	60.0	2.57	68.8	24.45	67.7		
		90	73.5	63.9	2.58	72.6	26.00	68.7	77.2	65.3	2.60	74.1	26.23	69.1	80.8	66.7	2.62	75.6	26.46	69.5		
		110	91.6	71.3	2.65	80.3	28.03	70.7	95.8	72.3	2.66	81.4	28.21	71.0	99.9	73.4	2.67	82.5	28.39	71.3		
	11.5	50	40.2	50.1	2.38	58.2	21.09	61.5	39.8	52.0	2.40	60.2	21.63	61.9	42.6	53.9	2.43	62.2	22.15	62.3		
		70	58.8	57.0	2.41	65.2	23.62	62.9	58.6	58.3	2.43	66.6	23.94	63.2	61.8	59.6	2.46	67.9	24.26	63.5		
		90	77.4	63.9	2.45	72.3	26.07	64.3	77.3	64.6	2.46	73.0	26.20	64.5	81.0	65.2	2.48	73.7	26.33	64.7		
		110	96.0	70.8	2.49	79.3	28.44	65.7	96.0	70.9	2.50	79.4	28.40	65.8	100.3	70.9	2.50	79.4	28.36	65.9		
	15	50	43.0	51.2	2.32	59.1	23.44	58.1	39.7	52.8	2.33	60.7	23.93	58.3	42.5	54.4	2.35	62.4	24.43	58.6		
		70	62.1	57.6	2.32	65.5	25.87	59.0	58.5	58.3	2.33	66.3	26.08	59.1	61.9	59.1	2.34	67.1	26.28	59.2		
		90	81.2	64.0	2.33	71.9	28.30	59.9	77.4	63.9	2.33	71.8	28.22	59.9	81.2	63.7	2.34	71.7	28.14	59.9		
		110	100.3	70.4	2.33	78.4	30.72	60.8	96.2	69.4	2.33	77.4	30.36	60.6	100.6	68.4	2.34	76.4	30.00	60.5		
70	8	50	38.2	45.8	2.99	56.0	15.32	84.4	40.6	48.4	3.02	58.7	16.00	85.1	43.0	50.9	3.05	61.3	16.69	85.8		
		70	55.5	56.4	3.10	67.0	18.21	87.3	58.5	58.8	3.11	69.4	18.87	87.9	61.6	61.1	3.13	71.8	19.52	88.5		
		90	72.7	67.0	3.20	77.9	20.92	90.1	76.5	69.2	3.21	80.1	21.56	90.6	80.2	71.3	3.21	82.3	22.21	91.2		
		110	Operation not recommended																			
	11.5	50	37.9	47.0	2.90	56.9	16.21	81.2	40.4	49.2	2.92	59.1	16.86	81.7	42.9	51.4	2.94	61.4	17.50	82.1		
		70	55.2	57.6	2.96	67.7	19.49	83.3	58.4	59.0	2.97	69.2	19.90	83.7	61.7	60.5	2.98	70.6	20.30	84.0		
		90	72.4	68.2	3.01	78.4	22.65	85.5	76.4	68.9	3.02	79.2	22.84	85.7	80.4	69.6	3.02	79.9	23.03	85.9		
		110	Operation not recommended																			
	15	50	37.6	48.2	2.81	57.8	17.15	77.9	40.2	50.0	2.82	59.6	17.76	78.2	42.9	51.8	2.82	61.4	18.37	78.4		
		70	54.9	58.8	2.81	68.4	20.89	79.4	58.3	59.3	2.82	68.9	21.03	79.5	61.8	59.8	2.83	69.5	21.17	79.6		
		90	72.1	69.3	2.82	78.9	24.62	80.9	76.4	68.6	2.83	78.2	24.28	80.8	80.7	67.9	2.83	77.5	23.95	80.7		
		110	89.4	79.9	2.82	89.5	28.33	82.3	94.5	77.9	2.83	87.6	27.53	82.0	99.6	75.9	2.84	85.6	26.73	81.8		
90	8	50	39.4	41.0	3.85	54.1	11.49	103.9	41.7	42.8	3.89	56.1	11.92	104.4	43.9	44.7	3.92	58.0	12.35	105.0		
		70	56.6	52.2	3.96	65.7	14.07	106.9	59.5	53.9	3.99	67.5	14.47	107.4	62.4	55.6	4.01	69.3	14.88	107.9		
		90	73.7	63.4	4.07	77.3	16.50	109.9	77.3	65.0	4.09	78.9	16.89	110.3	80.9	66.6	4.11	80.6	17.28	110.8		
		110	Operation not recommended																			
	11.5	50	39.2	41.8	3.73	54.5	11.20	100.7	41.5	43.5	3.76	56.3	11.56	101.1	43.8	45.1	3.79	58.0	11.92	101.5		
		70	56.4	52.7	3.80	65.7	13.88	103.0	59.4	54.1	3.82	67.1	14.15	103.3	62.4	55.4	3.84	68.5	14.42	103.6		
		90	73.6	63.7	3.86	76.8	16.47	105.2	77.3	64.7	3.88	77.9	16.66	105.5	81.0	65.7	3.90	79.0	16.85	105.7		
		110	Operation not recommended																			
	15	50	39.0	42.7	3.62	55.0	12.77	97.6	41.4	44.1	3.63	56.5	13.18	97.8	43.7	45.6	3.65	58.1	13.58	98.0		
		70	56.3	53.3	3.64	65.7	15.81	99.0	59.3	54.3	3.65	66.7	16.00	99.2	62.4	55.2	3.67	67.7	16.19	99.3		
		90	73.5	64.0	3.66	76.4	18.82	100.5	77.3	64.4	3.67	76.9	18.80	100.6	81.1	64.8	3.69	77.4	18.78	100.6		
		110	Operation not recommended																			
110	8	50	40.7	36.1	4.71	52.2	7.66	123.4	42.7	37.3	4.75	53.5	7.84	123.8	44.7	38.4	4.79	54.7	8.02	124.1		
		70	57.7	47.9	4.83	64.4	9.92	126.6	60.4	49.0	4.86	65.6	10.08	126.9	63.1	50.1	4.90	66.8	10.23	127.2		
		90	Operation not recommended																			
		110	Operation not recommended																			
	11.5	50	40.6	36.6	4.57	52.2	8.02	120.3	42.6	37.8	4.60	53.4	8.21	120.6	44.7	38.9	4.64	54.7	8.39	120.8		
		70	57.7	47.9	4.64	63.7	10.31	122.6	60.4	49.1	4.67	65.0	10.51	122.9	63.1	50.3	4.70	66.4	10.7	123.1		
		90	Operation not recommended																			
		110	Operation not recommended																			
	15	50	40.4	37.1	4.42	52.2	8.39	117.2	42.5	38.3	4.45	53.4	8.59	117.3	44.6	39.4	4.48	54.7	8.79	117.5		
		70	57.7	47.8	4.46	63.0	10.7	118.7	60.4	49.2	4.48	64.5	10.97	118.9	63.0	50.6	4.51	66.0	11.21	119.1		
		90	Operation not recommended																			
		110	Operation not recommended																			

EST = entering source fluid temperature to heat pump
 TC = total cooling capacity in MBTUH
 ELT = entering load fluid temperature to heat pump
 HR = heat rejected in MBTUH
 LST = leaving source fluid temperature from heat pump
 EER = energy efficiency ratio
 LLT = leaving load fluid temperature from heat pump

Performance Data cont.

060 Heating

Source		Load Flow-9 GPM							Load Flow-13.5GPM						Load Flow-18 GPM						
EST	Flow	ELT	LLT	HC	Power	HE	COP	LST	LLT	HC	Power	HE	COP	LST	LLT	HC	Power	HE	COP	LST	
° F	GPM	° F	° F	MBTUH	kW	MBTUH		° F	° F	MBTUH	kW	MBTUH		° F	° F	MBTUH	kW	MBTUH		° F	
25	13.5	60	Operation not recommended																		
		80	Operation not recommended																		
		100	Operation not recommended																		
		120	Operation not recommended																		
25	18	60	71.0	48.1	2.89	38.2	4.88	20.6	67.4	48.5	2.83	38.8	5.02	20.6	65.6	48.8	2.77	39.3	5.16	20.49	
		80	90.8	47.0	3.90	33.7	3.53	21.1	87.2	47.4	3.82	34.3	3.63	21.1	85.5	47.7	3.74	34.9	3.73	21.0	
		100	110.5	46.0	4.91	29.2	2.74	21.7	107.1	46.3	4.81	29.8	2.82	21.6	105.3	46.5	4.72	30.4	2.89	21.5	
		120	130.3	44.9	5.92	24.7	2.22	22.2	126.9	45.2	5.81	25.3	2.28	22.1	125.2	45.4	5.69	26.0	2.34	22.0	
30	9	60	71.7	51.1	2.89	41.2	5.18	20.6	64.4	51.5	2.85	41.7	5.29	20.4	57.0	51.8	2.81	42.2	5.40	20.3	
		80	91.3	49.3	3.92	35.9	3.69	21.8	88.5	49.6	3.85	36.5	3.78	21.6	85.7	49.9	3.78	37.0	3.87	21.5	
		100	110.9	47.5	4.94	30.6	2.82	23.0	108.2	47.8	4.85	31.2	2.89	22.8	105.5	48.1	4.76	31.8	2.96	22.7	
		120	130.5	45.7	5.97	25.3	2.24	24.2	127.9	46.0	5.85	26.0	2.30	24.0	125.3	46.2	5.73	26.6	2.36	23.9	
	30	13.5	60	71.9	52.0	2.9	41.9	5.19	22.8	66.7	52.2	2.85	42.5	5.36	22.7	61.6	52.5	2.8	43.0	5.54	22.7
			80	91.5	50.1	3.9	36.6	3.72	23.7	88.6	50.4	3.85	37.2	3.83	23.6	85.8	50.6	3.8	37.8	3.95	23.5
			100	111.0	48.2	4.9	31.3	2.85	24.7	108.3	48.5	4.84	31.9	2.93	24.6	105.6	48.8	4.7	32.6	3.02	24.4
			120	130.6	46.3	6.0	26.0	2.28	25.6	128.0	46.6	5.84	26.7	2.34	25.5	125.4	46.9	5.7	27.4	2.40	25.3
	30	18	60	72.1	52.8	2.97	42.7	5.21	25.1	69.1	53.0	2.86	43.3	5.45	25.0	66.1	53.2	2.74	43.8	5.69	25.0
			80	91.6	50.8	3.96	37.3	3.76	25.7	88.8	51.1	3.85	38.0	3.90	25.7	85.9	51.3	3.73	38.6	4.03	25.6
			100	111.2	48.9	4.95	32.0	2.89	26.3	108.4	49.2	4.84	32.7	2.98	26.3	105.7	49.5	4.72	33.4	3.07	26.2
			120	130.7	46.9	5.94	26.6	2.31	26.9	128.1	47.3	5.83	27.4	2.38	26.9	125.5	47.6	5.71	28.1	2.44	26.8
50	9	60	75.2	66.6	3.0	56.2	6.36	37.1	69.3	66.9	2.95	56.9	6.61	37.0	63.3	67.3	2.9	57.5	6.87	36.8	
		80	94.6	63.8	4.0	50.0	4.61	38.5	91.0	64.1	3.92	50.7	4.77	38.4	87.4	64.5	3.8	51.4	4.94	38.2	
		100	114.0	61.0	5.0	43.9	3.55	39.9	110.5	61.3	4.90	44.6	3.66	39.8	107.1	61.6	4.8	45.3	3.78	39.6	
		120	133.3	58.3	6.0	37.7	2.84	41.4	130.0	58.5	5.87	38.5	2.92	41.2	126.7	58.8	5.7	39.2	3.00	41.0	
	50	13.5	60	75.7	68.4	3.1	57.9	6.57	40.1	70.7	68.7	2.95	58.6	6.82	40.0	65.7	69.0	2.9	59.2	7.08	39.9
			80	95.0	65.5	4.0	51.7	4.75	41.2	91.3	65.8	3.93	52.4	4.91	41.1	87.6	66.1	3.8	53.1	5.08	41.0
			100	114.3	62.6	5.0	45.4	3.65	42.3	110.8	62.9	4.90	46.2	3.76	42.2	107.2	63.2	4.8	46.9	3.88	42.0
			120	133.7	59.7	6.0	39.2	2.91	43.4	130.3	60.0	5.87	40.0	2.99	43.2	126.9	60.4	5.7	40.8	3.08	43.1
	50	18	60	76.1	70.2	3.1	59.7	6.67	43.2	72.1	70.4	2.95	60.3	6.95	43.1	68.1	70.7	2.8	60.9	7.22	43.0
			80	95.4	67.2	4.0	53.3	4.84	43.9	91.6	67.4	3.93	54.0	5.02	43.8	87.8	67.7	3.8	54.7	5.19	43.7
			100	114.7	64.2	5.0	47.0	3.72	44.6	111.1	64.5	4.90	47.8	3.85	44.5	107.4	64.8	4.8	48.5	3.97	44.4
			120	134.0	61.2	6.0	40.6	2.97	45.3	130.5	61.5	5.87	41.5	3.07	45.2	127.1	61.9	5.7	42.3	3.16	45.1
70	9	60	78.8	82.0	3.19	71.1	7.53	53.7	74.1	82.4	3.05	72.0	7.93	53.5	69.5	82.8	2.91	72.9	8.34	53.3	
		80	97.9	78.3	4.14	64.1	5.53	55.3	93.5	78.6	4.00	65.0	5.77	55.1	89.0	79.0	3.85	65.8	6.01	54.9	
		100	117.1	74.5	5.10	57.1	4.28	56.9	112.8	74.9	4.95	58.0	4.44	56.7	108.6	75.2	4.80	58.8	4.59	56.5	
		120	136.2	70.8	6.05	50.2	3.43	58.5	132.2	71.1	5.90	51.0	3.54	58.3	128.2	71.4	5.74	51.8	3.64	58.1	
	70	13.5	60	79.4	84.8	3.2	73.9	7.83	57.5	74.6	85.1	3.05	74.7	8.18	57.3	69.8	85.5	2.9	75.4	8.54	57.2
			80	98.5	80.9	4.1	66.7	5.73	58.7	93.9	81.2	4.00	67.6	5.95	58.5	89.3	81.6	3.9	68.4	6.18	58.4
			100	117.6	77.0	5.1	59.6	4.42	59.9	113.3	77.3	4.96	60.4	4.57	59.8	108.9	77.7	4.8	61.3	4.74	59.6
			120	136.7	73.1	6.1	52.4	3.53	61.1	132.6	73.5	5.91	53.3	3.64	61.0	128.5	73.8	5.7	54.2	3.76	60.8
	70	18	60	80.0	87.5	3.15	76.7	8.14	61.2	75.1	87.8	3.05	77.4	8.44	61.1	70.1	88.1	2.95	78.0	8.75	61.1
			80	99.1	83.5	4.13	69.4	5.92	62.1	94.4	83.8	4.01	70.1	6.13	62.0	89.6	84.1	3.88	70.9	6.35	61.9
			100	118.2	79.4	5.11	62.0	4.55	62.9	113.7	79.8	4.96	62.9	4.72	62.8	109.2	80.2	4.82	63.7	4.88	62.7
			120	137.3	75.4	6.09	54.6	3.63	63.7	133.0	75.8	5.92	55.6	3.76	63.6	128.7	76.2	5.75	56.6	3.88	63.5
90	9	60	82.1	96.5	3.22	85.5	8.78	70.4	76.3	94.0	3.06	83.6	9.03	70.9	70.5	91.5	2.89	81.6	9.28	71.3	
		80	101.1	92.2	4.22	77.8	6.40	72.2	95.7	90.8	4.03	77.1	6.62	72.3	90.2	89.4	3.83	76.3	6.84	72.5	
		100	Operation not recommended																		
		120	Operation not recommended																		
	90	13.5	60	82.6	98.5	3.3	87.3	8.86	75.1	76.6	95.5	3.08	85.0	9.09	75.5	70.6	92.6	2.9	82.7	9.36	75.9
			80	101.5	93.9	4.3	79.4	6.47	76.5	95.9	92.3	4.05	78.4	6.68	76.6	90.4	90.6	3.8	77.5	6.91	76.8
			100	120.5	89.4	5.3	71.4	4.98	77.8	115.3	89.0	5.02	71.9	5.19	77.7	110.2	88.6	4.8	72.3	5.42	77.7
			120	Operation not recommended																	
	90	18	60	83.0	100.4	3.29	89.2	8.94	79.8	76.9	97.1	3.10	86.5	9.19	80.1	70.7	93.7	2.91	83.8	9.43	80.4
			80	101.9	95.6	4.29	81.0	6.54	80.7	96.2	93.7	4.07	79.8	6.75	80.9	90.5	91.8	3.86	78.7	6.97	81.0
			100	120.8	90.9	5.28	72.8	5.04	81.7	115.6	90.4	5.05	73.2	5.26	81.6	110.3	90.0	4.81	73.6	5.48	81.6
			120	Operation not recommended																	

EST = entering source fluid temperature to heat pump
 HC = total heating capacity in MBTUH
 ELT = entering load fluid temperature to heat pump
 HE = heat extracted in MBTUH
 LST = leaving source fluid temperature from heat pump
 COP = coefficient of performance
 LLT = leaving load fluid temperature from heat pump

Performance Data cont.

060 Cooling

Source		Load Flow-9 GPM							Load Flow-13.5 GPM							Load Flow-18 GPM						
EST °F	Flow GPM	ELT °F	LLT °F	TC MBTUH	Power kW	HR MBTUH	EER	LST °F	LLT °F	TC MBTUH	Power kW	HR MBTUH	EER	LST °F	LLT °F	TC MBTUH	Power kW	HR MBTUH	EER	LST °F		
30	9	50	36.0	60.9	2.10	68.1	29.00	45.6	39.3	62.9	2.17	70.3	28.96	46.1	42.6	64.8	2.24	72.4	28.93	46.6		
		70	54.4	68.0	2.18	75.4	31.24	47.3	58.1	69.5	2.23	77.1	31.21	47.7	61.9	71.0	2.28	78.7	31.17	48.0		
		90	72.8	75.1	2.25	82.8	33.33	49.0	77.0	76.1	2.28	83.9	33.34	49.2	81.2	77.1	2.31	85.0	33.34	49.5		
		110	91.2	82.2	2.33	90.2	35.28	50.7	95.8	82.8	2.34	90.7	35.36	50.8	100.5	83.3	2.35	91.3	35.45	50.9		
	13.5	50	36.3	59.8	2.08	66.9	28.75	41.6	39.4	62.4	2.10	69.6	29.68	42.0	42.6	65.0	2.13	72.3	30.59	42.4		
		70	55.1	65.0	2.12	72.3	30.67	42.6	58.6	66.9	2.13	74.2	31.35	42.9	62.1	68.8	2.15	76.1	32.03	43.2		
		90	73.9	70.2	2.16	77.6	32.52	43.6	77.8	71.4	2.16	78.8	32.98	43.8	81.7	72.5	2.17	79.9	33.44	44.0		
		110	92.7	75.5	2.20	83.0	34.30	44.7	97.0	75.9	2.20	83.3	34.56	44.7	101.3	76.3	2.19	83.7	34.82	44.8		
	18	50	36.6	58.7	2.06	65.7	28.50	37.5	39.5	62.0	2.04	68.9	30.47	37.9	42.5	65.2	2.01	72.1	32.44	38.3		
		70	55.8	62.0	2.06	69.1	30.06	37.9	59.1	64.3	2.04	71.2	31.53	38.2	62.4	66.5	2.02	73.4	32.99	38.4		
		90	75.0	65.4	2.07	72.4	31.63	38.3	78.6	66.6	2.05	73.6	32.59	38.4	82.2	67.9	2.02	74.8	33.54	38.6		
		110	94.3	68.7	2.07	75.8	33.19	38.7	98.2	69.0	2.05	75.9	33.64	38.7	102.1	69.2	2.03	76.1	34.09	38.7		
50	9	50	37.0	56.9	2.76	66.3	22.26	65.2	40.0	59.1	2.81	68.6	22.49	65.7	43.0	61.2	2.87	71.0	22.72	66.3		
		70	54.5	67.8	2.89	77.7	25.02	67.8	58.1	69.6	2.92	79.6	25.28	68.2	61.8	71.4	2.95	81.5	25.53	68.7		
		90	72.0	78.7	3.02	89.0	27.55	70.4	76.3	80.2	3.02	90.5	27.87	70.7	80.6	81.6	3.03	92.0	28.20	71.1		
		110	89.5	89.7	3.15	100.4	29.87	73.0	94.5	90.8	3.13	101.4	30.30	73.2	99.5	91.9	3.11	102.4	30.73	73.5		
	13.5	50	37.0	56.7	2.70	65.9	20.99	61.3	40.0	59.1	2.73	68.4	21.69	61.8	42.9	61.6	2.75	71.0	22.37	62.2		
		70	54.8	66.2	2.77	75.7	23.88	63.1	58.4	68.2	2.79	77.7	24.48	63.5	62.0	70.2	2.80	79.8	25.08	63.8		
		90	72.7	75.7	2.84	85.4	26.63	64.9	76.8	77.3	2.85	87.0	27.16	65.2	81.0	78.9	2.85	88.6	27.70	65.4		
		110	90.5	85.2	2.92	95.2	29.24	66.7	95.2	86.4	2.91	96.3	29.73	66.8	100.0	87.6	2.90	97.5	30.22	67.0		
	18	50	37.1	56.5	2.65	65.5	22.64	57.5	40.0	59.2	2.64	68.2	23.92	57.8	42.9	62.0	2.64	71.0	25.19	58.1		
		70	55.2	64.6	2.66	73.6	25.36	58.4	58.6	66.8	2.66	75.9	26.36	58.7	62.1	69.1	2.66	78.1	27.36	59.0		
		90	73.3	72.7	2.67	81.8	28.05	59.4	77.3	74.4	2.67	83.5	28.77	59.6	81.3	76.2	2.67	85.3	29.48	59.8		
		110	91.5	80.8	2.68	89.9	30.71	60.3	96.0	82.1	2.69	91.2	31.15	60.4	100.5	83.3	2.69	92.5	31.58	60.6		
70	9	50	37.9	52.9	3.41	64.5	15.51	84.8	40.6	55.3	3.45	67.0	16.01	85.4	43.4	57.6	3.49	69.5	16.50	85.9		
		70	54.5	67.6	3.60	79.9	18.80	88.3	58.1	69.8	3.61	82.1	19.35	88.8	61.8	71.9	3.61	84.2	19.89	89.3		
		90	71.1	82.4	3.78	95.3	21.77	91.8	75.6	84.3	3.76	97.1	22.41	92.2	80.1	86.1	3.74	98.9	23.05	92.7		
		110	Operation not recommended																			
	13.5	50	37.7	53.6	3.32	64.9	16.13	81.1	40.5	55.9	3.35	67.3	16.67	81.5	43.3	58.2	3.38	69.7	17.20	82.0		
		70	54.6	67.4	3.42	79.1	19.68	83.6	58.2	69.6	3.44	81.3	20.22	84.0	61.8	71.7	3.46	83.5	20.76	84.4		
		90	71.4	81.2	3.53	93.2	23.02	86.1	75.8	83.3	3.53	95.3	23.59	86.5	80.2	85.3	3.53	97.4	24.17	86.8		
		110	Operation not recommended																			
	18	50	37.6	54.2	3.23	65.2	16.78	77.5	40.4	56.5	3.25	67.5	17.37	77.7	43.3	58.7	3.27	69.9	17.95	78.0		
		70	54.6	67.1	3.25	78.2	20.65	79.0	58.2	69.4	3.27	80.5	21.18	79.2	61.8	71.6	3.30	82.9	21.72	79.5		
		90	71.7	80.0	3.27	91.2	24.46	80.4	76.0	82.3	3.30	93.5	24.95	80.7	80.3	84.5	3.32	95.8	25.43	81.0		
		110	88.7	92.9	3.29	104.1	28.24	81.9	93.8	95.2	3.32	106.5	28.66	82.2	98.8	97.4	3.35	108.8	29.07	82.5		
90	9	50	39.3	46.7	4.43	61.8	11.47	104.1	41.8	48.6	4.45	63.8	11.86	104.6	44.2	50.6	4.47	65.8	12.25	105.1		
		70	56.1	60.9	4.57	76.5	14.28	107.5	59.3	62.8	4.58	78.4	14.70	108.0	62.6	64.7	4.59	80.4	15.11	108.4		
		90	72.8	75.1	4.72	91.2	16.89	110.9	76.9	77.0	4.72	93.1	17.35	111.3	81.0	78.9	4.72	95.0	17.80	111.8		
		110	Operation not recommended																			
	13.5	50	39.2	47.3	4.29	62.0	11.03	100.6	41.7	49.2	4.31	63.9	11.42	101.0	44.2	51.1	4.33	65.8	11.80	101.3		
		70	56.0	61.1	4.38	76.0	13.95	103.1	59.3	63.0	4.39	78.0	14.35	103.4	62.6	65.0	4.41	80.0	14.74	103.8		
		90	72.9	74.8	4.46	90.0	16.76	105.5	76.9	76.8	4.47	92.1	17.17	105.9	81.0	78.9	4.49	94.2	17.57	106.2		
		110	Operation not recommended																			
	18	50	39.0	48.0	4.16	62.2	12.50	97.1	41.5	49.8	4.17	64.0	12.91	97.3	44.1	51.6	4.19	65.8	13.33	97.5		
		70	56.0	61.2	4.18	75.5	15.73	98.6	59.3	63.2	4.20	77.5	16.15	98.9	62.5	65.2	4.22	79.6	16.57	99.1		
		90	72.9	74.4	4.21	88.8	18.93	100.2	77.0	76.6	4.23	91.1	19.35	100.4	81.0	78.8	4.26	93.3	19.76	100.7		
		110	Operation not recommended																			
110	9	50	40.7	40.4	5.44	59.0	7.43	123.5	42.9	42.0	5.44	60.5	7.71	123.9	45.0	43.5	5.44	62.1	8.00	124.2		
		70	57.6	54.1	5.54	73.1	9.77	126.7	60.5	55.9	5.56	74.8	10.05	127.1	63.4	57.6	5.57	76.6	10.33	127.5		
		90	Operation not recommended																			
		110	Operation not recommended																			
	13.5	50	40.6	41.1	5.27	59.1	7.81	120.1	42.8	42.5	5.27	60.5	8.07	120.4	45.0	44.0	5.27	61.9	8.34	120.6		
		70	57.5	54.7	5.33	72.9	10.27	122.5	60.4	56.5	5.34	74.7	10.56	122.8	63.3	58.2	5.36	76.5	10.86	123.1		
		90	Operation not recommended																			
		110	Operation not recommended																			
	18	50	40.4	41.8	5.09	59.2	8.21	116.8	42.7	43.1	5.10	60.5	8.46	116.9	44.9	44.4	5.10	61.8	8.71	117.1		
		70	57.3	55.3	5.12	72.8	10.81	118.3	60.3	57.1	5.13	74.6	11.12	118.5	63.3	58.8	5.14	76.3	11.43	118.7		
		90	Operation not recommended																			
		110	Operation not recommended																			

EST = entering source fluid temperature to heat pump
 TC = total cooling capacity in MBTUH
 ELT = entering load fluid temperature to heat pump
 HR = heat rejected in MBTUH
 LST = leaving source fluid temperature from heat pump
 EER = energy efficiency ratio
 LLT = leaving load fluid temperature from heat pump

Service Parts List

Aurora Controls

Part Description		024	050	060
		208-230/60/1	208-230/60/1	208-230/60/1
Refrigeration Components	Compressor	34P583-01	34P580-01	34P646-01
	Compressor Capacitor	16P008D20	16P008D25	16P008D41
	Compressor Sound Jacket	92P504A05	92P519-02	92P519-02
	Thermal Expansion Valve	33P605-18	33P605-15	33P605-17
	Filter Drier for 'Reversible Models'	36P500B01	36P500B02	36P500B02
	Filter Drier for 'Heating Only' Models			
	Reversing Valve with Coil	33P506-04	33P526-04	33P526-04
	Hot Water Generator (Desuperheater)	n/a	62I516-03	62I516-03
	Source Coaxial Heat Exchanger (copper)	62I573-01	62I543-04	62I557-01
	Source Coaxial Heat Exchanger (cupronickel)	62I573-02	62I543-03	62I557-02
	Load Coaxial Heat Exchanger (copper)	62I573-01	62I543-04	62I557-01
	Load Coaxial Heat Exchanger (cupronickel)	62I573-02	62I543-03	62I557-02
	DHW Load Coax Vented Double Wall (copper)	62P549-01	n/a	n/a
Safeties / Sensors	High Pressure Switch	35P506B02	35P506B02	35P506B02
	Low Pressure Switch	35P506B01	35P506B01	35P506B01
	Discharge Pressure Transducer	35P555-01	35P555-01	35P555-01
	Suction Pressure Transducer	35P555-02	35P555-02	35P555-02
Electrical	Compressor Contactor	13P004A03	13P004A03	13P004A03
	Transformer	15P501-02	15P501-02	15P501-02
	Relay 24 VDC SPDT	13P711-01	13P711-01	13P711-01
	Circuit Breaker 5 Amp	19P583-01	19P583-01	19P583-01
	Aurora Board Programmed	17X553-10	17X553-10	17X553-10
	Aurora Expansion Board (AXB)	17X597-12	17X597-12	17X597-12
	Thermistor-Feerze Protection	12P560-06	12P560-06	12P560-06
	Power Block 15 amp 2 pole	12P500A01	12P500A01	12P500A01
	Current Transducer	12P557-01	12P557-01	12P557-01
	IntelliStart Soft Starter	IS1B08-16SN	IS1B16-32SN	IS1B16-32SN
	Grounding Lug	12P004A	12P004A	12P004A

Decommissioning

Before carrying out this procedure, it is essential that the technician is completely familiar with the equipment and all its detail. It is recommended good practice that all refrigerants are recovered safely. Prior to the task being carried out, an oil and refrigerant sample shall be taken in case analysis is required prior to re-use of recovered refrigerant. It is essential that electrical power is available before the task is commenced.

1. Become familiar with the equipment and its operation.
2. Isolate system electrically.
3. Before attempting the procedure, ensure that:
 - mechanical handling equipment is available, if required, for handling refrigerant cylinders;
 - all personal protective equipment is available and being used correctly;
 - the recovery process is supervised at all times by a competent person;
 - recovery equipment and cylinders conform to the appropriate standards.
4. Pump down refrigerant system, if possible.
5. If a vacuum is not possible, make a manifold so that refrigerant can be removed from various parts of the system.
6. Make sure that cylinder is situated on the scales before recovery takes place.
7. Start the recovery machine and operate in accordance with instructions.
8. Do not overfill cylinders (no more than 80 % volume liquid charge).
9. Do not exceed the maximum working pressure of the cylinder, even temporarily.
10. When the cylinders have been filled correctly and the process completed, make sure that the cylinders and the equipment are removed from site promptly and all isolation valves on the equipment are closed off.
11. Recovered refrigerant shall not be charged into another REFRIGERATING SYSTEM unless it has been cleaned and checked

Decommissioning - Unit Labeling Requirements

Equipment shall be labelled stating that it has been de-commissioned and emptied of refrigerant. The label shall be dated and signed. For appliances containing FLAMMABLE REFRIGERANTS, ensure that there are labels on the equipment stating the equipment contains FLAMMABLE REFRIGERANT.

Refrigerant Recovery

When removing refrigerant from a system, either for servicing or decommissioning, it is recommended good practice that all refrigerants are removed safely.

When transferring refrigerant into cylinders, ensure that only appropriate refrigerant recovery cylinders are employed. Ensure that the correct number of cylinders for holding the total system charge is available. All cylinders to be used are designated for the recovered refrigerant and labelled for that refrigerant (i.e. special cylinders for the recovery of refrigerant). Cylinders shall be complete with pressure-relief valve and associated shut-off valves in good working order. Empty recovery cylinders are evacuated and, if possible, cooled before recovery occurs.

The recovery equipment shall be in good working order with a set of instructions concerning the equipment that is at hand and shall be suitable for the recovery of the flammable refrigerant. If in doubt, the manufacturer should be consulted. In addition, a set of calibrated weighing scales shall be available and in good working order. Hoses shall be complete with leak-free disconnect couplings and in good condition.

The recovered refrigerant shall be processed according to local legislation in the correct recovery cylinder, and the relevant waste transfer note arranged. Do not mix refrigerants in recovery units and especially not in cylinders.

If compressors or compressor oils are to be removed, ensure that they have been evacuated to an acceptable level to make certain that flammable refrigerant does not remain within the lubricant. The compressor body shall not be heated by an open flame or other ignition sources to accelerate this process. When oil is drained from a system, it shall be carried out safely.

Refrigerant Removal and Evacuation

When breaking into the refrigerant circuit to make repairs – or for any other purpose conventional procedures shall be used. However, for flammable refrigerants it is important that best practice be followed, since flammability is a consideration.

The following procedure shall be adhered to:

- safely remove refrigerant following local and national regulations;
- evacuate;
- purge the circuit with inert gas (optional for A2L);
- evacuate (optional for A2L);
- continuously flush or purge with inert gas when using flame to open circuit; and
- open the circuit.

The refrigerant charge shall be recovered into the correct recovery cylinders if venting is not allowed by local and national codes. For appliances containing flammable refrigerants, the system shall be purged with oxygen-free nitrogen to render the appliance safe for flammable refrigerants.

This process might need to be repeated several times. Compressed air or oxygen shall not be used for purging refrigerant systems. For appliances containing flammable refrigerants, refrigerants purging shall be achieved by breaking the vacuum in the system with oxygen-free nitrogen and continuing to fill until the working pressure is achieved, then venting to atmosphere, and finally pulling down to a vacuum (optional for A2L). This process shall be repeated until no refrigerant is within the system (optional for A2L). When the final oxygen-free nitrogen charge is used, the system shall be vented down to atmospheric pressure to enable work to take place. The outlet for the vacuum pump shall not be close to any potential ignition sources, and ventilation shall be available.

Charging Procedures

In addition to conventional charging procedures, the following requirements shall be followed.

- Ensure that contamination of different refrigerants does not occur when using charging equipment.
- Hoses or lines shall be as short as possible to minimise the amount of refrigerant contained in them.
- Cylinders shall be kept in an appropriate position according to the instructions.
- Ensure that the REFRIGERATING SYSTEM is earthed prior to charging the system with refrigerant.
- Label the system when charging is complete (if not already).
- Extreme care shall be taken not to overfill the REFRIGERATING SYSTEM.

Prior to recharging the system, it shall be pressure-tested with the appropriate purging gas. The system shall be leak-tested on completion of charging but prior to commissioning. A follow up leak test shall be carried out prior to leaving the site.

Revision Guide

Pages:	Description:	Date:	By:
All	Document Creation	3 Oct., 2024	SW



OMW5-0025Y 12/24



Product: **Affinity Series**
Type: Geothermal Hydronic Heat Pumps
Size: 2-5 Ton Single Capacity

Document Type: Operation & Maintenance
Part Number: OMW5-0025Y
Release Date: 12/24